



TL tekza
teknik hırdavat



TEKNIK
Cutting Tools

FİYAT LİSTESİ
10-01-2024

45° SNKX 1206

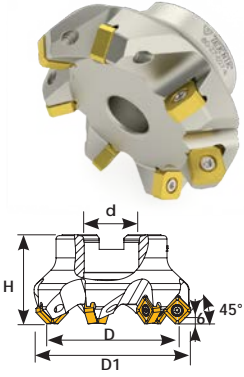

Sipariş Kodu	Ürün Kodu	Ölçüler (mm)						Uç	Fiyat
		D	D1	d	Z	H			
T319	D040 d16 Z03 SNKX 12	40	53	16	3	45	0,417		₺1.143
T320	D050 d22 Z04 SNKX 12	50	63	22	4	44	0,593		₺1.350
T322	D063 d22 Z06 SNKX 12	63	76	22	6	44	0,710	SNKX 1206	₺2.036
T325	D080 d27 Z07 SNKX 12	80	93	27	7	52	1,334		₺2.358
T330	D100 d32 Z08 SNKX 12	100	113	32	8	52	1,926		₺2.729
T332	D125 d40 Z10 SNKX 12	125	138	40	10	63	3,780		₺3.646
T334	D160 d40 Z12 SNKX 12	160	173	40	12	63	5,380		₺4.611
T335	D200 d60 Z14 SNKX 12	200	213	60	14	63	6,690		₺6.148
		TC076 M4x12,5		T15					

KRLY-PLBT-BHLR Ucuna Uygundur.

45° SNMU 1305

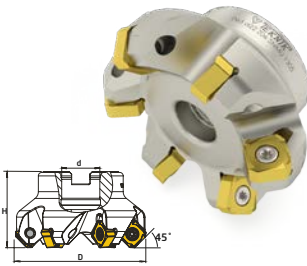

Sipariş Kodu	Ürün Kodu	Ölçüler (mm)					Uç	Fiyat	
		D	d	Z	H				
T234	D050 d22 Z04 SNMU 13	50	22	4	44	0,480		₺1.350	
T235	D063 d22 Z06 SNMU 13	63	22	6	44	0,645	SNMU 1305	₺2.036	
T236	D080 d27 Z07 SNMU 13	80	27	7	52	1,147	ISCR	₺2.358	
T237	D100 d32 Z08 SNMU 13	100	32	8	52	1,487		₺2.729	
T238	D125 d40 Z10 SNMU 13	125	40	10	63	3,610		₺3.646	
		TC083 M5x12		T20					

ISCR Ucuna Uygundur.

45° SNEU 1206

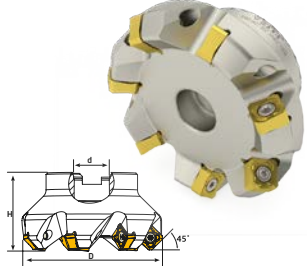

Sipariş Kodu	Ürün Kodu	Ölçüler (mm)					Uç	Fiyat	
		D	d	Z	H				
T164	D050 d22 Z05 SNEU 12	50	22	5	40	0,447		₺1.684	
T165	D063 d22 Z06 SNEU 12	63	22	6	40	0,582	SNEU 1206	₺2.036	
T166	D080 d27 Z07 SNEU 12	80	27	7	50	1,252		₺2.358	
T167	D100 d32 Z08 SNEU 12	100	32	8	50	1,925		₺2.729	
T168	D125 d40 Z10 SNEU 12	125	40	10	63	3,516		₺3.646	
		TC083 M5x12		T20					

XTC-GSC-WLTR Ucuna Uygundur.

45° SNKX 1206-ONHX 0505

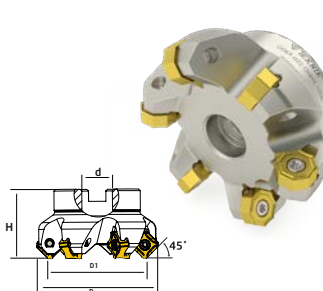

Sipariş Kodu	Ürün Kodu	Ölçüler (mm)						Uç	Fiyat
		D	D1	d	Z	H			
T623	D050 d22 Z04 SNKX 12 ONHX 05	50	42,4	22	4	40	0,458		₺1.350
T624	D063 d22 Z06 SNKX 12 ONHX 05	63	55,4	22	6	40	0,608	SNKX 1206	₺2.036
T625	D080 d27 Z07 SNKX 12 ONHX 05	80	72,4	27	7	50	1,051	ONHX 0505	₺2.358
T626	D100 d32 Z08 SNKX 12 ONHX 05	100	92,4	32	8	50	1,813	PLBT	₺2.729
T627	D125 d40 Z10 SNKX 12 ONHX 05	125	117,4	40	10	63	3,277		₺3.646
T628	D160 d40 Z12 SNKX 12 ONHX 05	160	152,4	40	12	63	4,577		₺4.660
		TC074 M4x10		T15					

PLBT Ucuna Uygundur.

45° SNKX 1606-ONHX 0606

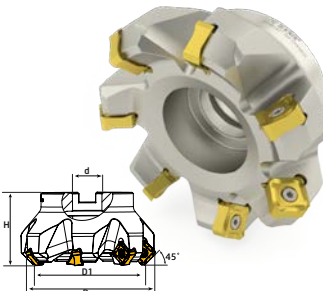

Sipariş Kodu	Ürün Kodu	Ölçüler (mm)						Uç	Fiyat
		D	D1	d	Z	H			
T629	D063 d22 Z05 SNKX 16 ONHX 06	63	63	22	5	50	0,776		₺1.684
T630	D080 d27 Z06 SNKX 16 ONHX 06	80	80	27	6	50	2,013	SNKX 1606	₺2.036
T631	D100 d32 Z07 SNKX 16 ONHX 06	100	100	32	7	63	2,750	ONHX 0606	₺2.405
T632	D125 d40 Z08 SNKX 16 ONHX 06	125	125	40	8	63	4,026	PLBT	₺2.901
T633	D160 d40 Z10 SNKX 16 ONHX 06	160	160	40	10	63	4,712		₺3.866
T634	D200 d60 Z12 SNKX 16 ONHX 06	200	200	60	12	63	8,112		₺5.453
		TC083 M5x12		T20					

PLBT Ucuna Uygundur

45° SDHT 1204

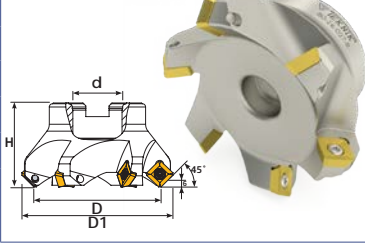

Sipariş Kodu	Ürün Kodu	Ölçüler (mm)						Uç	Fiyat
		D	D1	d	Z	H			
T300	D063 d22 Z05 SDHT 12	63	77	22	5	45	0,630		₺1.440
T302	D080 d27 Z06 SDHT 12	80	94	27	6	52	1,200	SDHT 1204	₺1.684
T304	D100 d32 Z07 SDHT 12	100	114	32	7	62	2,040	ISO	₺2.036
T305	D125 d40 Z08 SDHT 12	125	139	40	8	62	4,095		₺2.729

45° SEET 12T3 R245

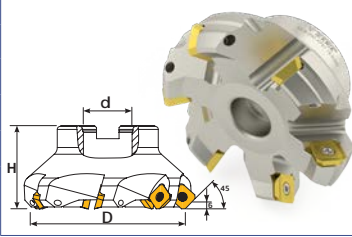

Sipariş Kodu	Ürün Kodu	Ölçüler (mm)					Uç	Fiyat	
		D	d	Z	H				
T435	D063 d22 Z05 SEET 12	63	22	5	50	0,815		₺1.440	
T436	D080 d27 Z06 SEET 12	80	27	6	52	1,305	SEET 12T3	₺1.684	
T437	D100 d32 Z07 SEET 12	100	32	7	55	1,715	R245	₺2.036	
T438	D125 d40 Z08 SEET 12	125	40	8	62	3,427		₺2.629	

ZCC -SNDVK-XTC Ucuna Uygundur.

45° SEET 12T3 R245

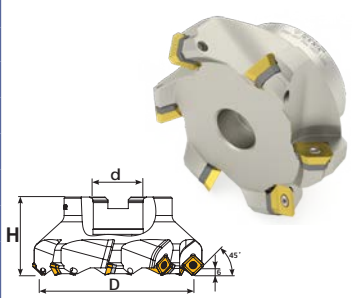

Sipariş Kodu	Ürün Kodu	Ölçüler (mm)					Uç	Fiyat
		D	d	Z	H			
T560	D050 d22 Z04 SEET 12	50	22	4	40	0,345		₺1.786
T562	D063 d22 Z05 SEET 12	63	22	5	40	0,505	SEET 12T3	₺2.036
T564	D080 d27 Z06 SEET 12	80	27	6	50	1,206	R245	₺2.358
T566	D100 d32 Z07 SEET 12	100	32	7	50	1,812		₺2.629
T568	D125 d40 Z08 SEET 12	125	40	8	63	3,390		₺3.174
T570	D160 d40 Z10 SEET 12	160	40	10	63	4,590		₺4.218

ZCC -SNDVK-XTC Ucuna Uygundur.

45° ONMX 0806

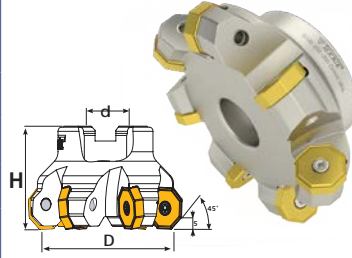

Sipariş Kodu	Ürün Kodu	Ölçüler (mm)					Uç	Fiyat
		D	d	Z	H			
T780	D063 d22 Z05 ONMX 08	63	22	5	40	1,063	ONMX 0806 KRL	₺1.684
T782	D080 d27 Z06 ONMX 08	80	27	6	50	0,532	ONMX 0806 ISCR	₺2.036
T784	D100 d32 Z07 ONMX 08	100	32	7	50	1,067	ONMU 0806 YG1	₺2.405
T786	D125 d40 Z08 ONMX 08	125	40	8	63	3,574	ONKX 0806 LMN	₺3.000

KRLY-ISCR-YG1-LMN Ucuna Uygundur.

45° ONMX 0606

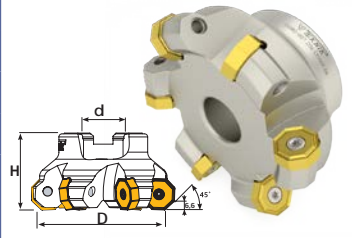

Sipariş Kodu	Ürün Kodu	Ölçüler (mm)					Uç	Fiyat
		D	d	Z	H			
T790	D063 d22 Z05 ONMX 06	63	22	5	45	0,657		₺1.684
T791	D080 d27 Z06 ONMX 06	80	27	6	50	1,110	ONMX 0606	₺2.036
T792	D100 d32 Z07 ONMX 06	100	32	7	52	1,701	KRLY	₺2.405

KRLY Ucuna Uygundur.

55° HNHX 1006

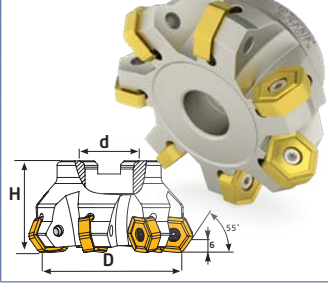

TGTC Ucuna Uygundur

Sipariş Kodu	Ürün Kodu	Ölçüler (mm)					Uç	Fiyat
		D	d	Z	H	kg		
T470	D063 d22 Z05 HNHX 10	63	22	5	50	0,675		₺1.684
T472	D080 d27 Z07 HNHX 10	80	27	7	50	1,063	HNHX 1006	₺2.358
T474	D100 d32 Z09 HNHX 10	100	32	9	62	2,023	TGTC	₺3.071
T476	D125 d40 Z10 HNHX 10	125	40	10	62	3,331		₺3.669
T478	D160 d40 Z12 HNHX 10	160	40	12	62	4,724		₺4.660
		TC083 M5x12		T20				

PNMU 1206

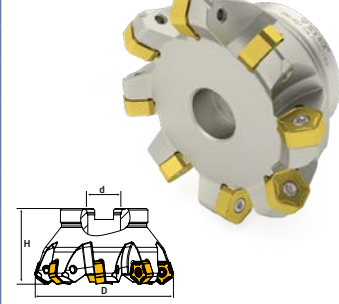

YG1 Ucuna Uygundur.

Sipariş Kodu	Ürün Kodu	Ölçüler (mm)					Uç	Fiyat
		D	d	Z	H	kg		
T722	D050 d22 Z04 PNMU 12	50	22	4	40	0,371		₺1.350
T723	D063 d22 Z05 PNMU 12	63	22	5	40	0,594	PNMU 1206	₺1.684
T724	D080 d27 Z08 PNMU 12	80	27	8	50	1,273	YG1	₺2.560
T725	D100 d32 Z10 PNMU 12	100	32	10	50	1,901		₺3.291
T726	D125 d40 Z10 PNMU 12	125	40	10	63	4,070		₺3.669
		TC074 M4x10		T15				

45° ONMU 0505

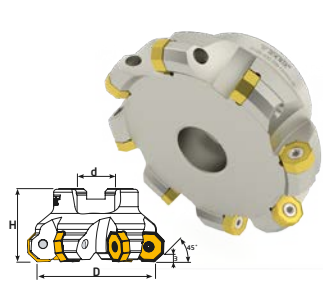

ISCR Ucuna Uygundur.

Sipariş Kodu	Ürün Kodu	Ölçüler (mm)					Uç	Fiyat
		D	d	Z	H	kg		
T794	D063 d22 Z06 ONMU 05	63	22	6	45	0,652		₺2.036
T796	D080 d27 Z07 ONMU 05	80	27	7	50	1,202	ONMU 0505	₺2.358
T798	D100 d32 Z08 ONMU 05	100	32	8	52	1,842	ISCR	₺2.729
T800	D125 d40 Z10 ONMU 05	125	40	10	62	3,537		₺3.646
T801	D160 d40 Z12 ONMU 05	160	40	12	62	4,863		₺4.640
		TC085 M5x12		T20				

55° HNGX 0906

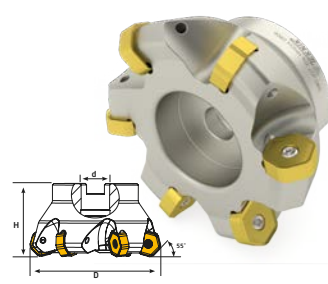

PRMT Ucuna Uygundur.

Sipariş Kodu	Ürün Kodu	Ölçüler (mm)					Uç	Fiyat
		D	d	Z	H	kg		
T418	D063 d22 Z06 HNGX 09	63	22	6	40	0,518		₺2.036
T419	D080 d27 Z06 HNGX 09	80	27	6	50	1,067	HNGX 0906	₺2.036
T420	D100 d32 Z08 HNGX 09	100	32	8	50	1,542	PRMT	₺2.729
T421	D125 d40 Z08 HNGX 09	125	40	8	63	3,314		₺3.024
T422	D160 d40 Z12 HNGX 09	160	40	12	63	3,962		₺4.640
		TC080 M4,5x11		T15				

43° ODHT 0605

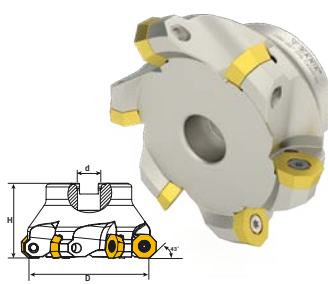

WLTR Ucuna Uygundur.

Sipariş Kodu	Ürün Kodu	Ölçüler (mm)					Uç	Fiyat
		D	d	Z	H	kg		
T210	D063 d22 Z05 ODHT 06	63	22	5	40	0,610		₺1.586
T211	D080 d27 Z06 ODHT 06	80	27	6	50	1,070	ODHT 0605	₺1.983
T212	D100 d32 Z07 ODHT 06	100	32	7	52	1,765	WLTR	₺2.358
T213	D125 d40 Z08 ODHT 06	125	40	8	62	3,528		₺3.024
		TC083 M5x12		T20				

43° OFCR 0704

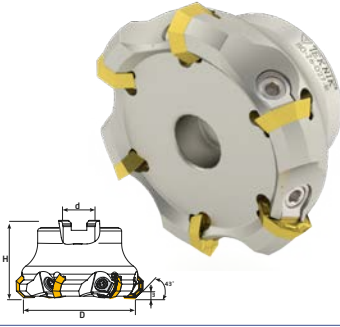

Sipariş Kodu	Ürün Kodu	Ölçüler (mm)					Uç	Fiyat
		D	d	Z	H	kg		
T260	D050 d22 Z04 OFCR 07	50	22	4	45	0,488		₺1.350
T262	D063 d22 Z04 OFCR 07	63	22	4	45	0,722	OFCR 0704	₺1.684
T264	D080 d27 Z06 OFCR 07	80	27	6	50	1,205	ISO	₺2.036
T266	D100 d32 Z08 OFCR 07	100	32	8	50	1,654		₺2.729
T268	D125 d40 Z09 OFCR 07	125	40	9	62	3,510		₺3.271
T269	D160 d40 Z12 OFCR 07	160	40	12	62	5,112		₺4.640
		BK300	TC300 M8x18	4 Allen				

90° XNEX 0806

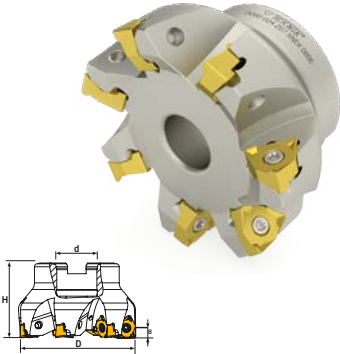

Sipariş Kodu	Ürün Kodu	Ölçüler (mm)					Uç	Fiyat
		D	d	Z	H	kg		
T840	D050 d22 Z04 XNEX 08	50	22	4	45	0,400		₺1.350
T841	D050 d22 Z05 XNEX 08	50	22	5	45	0,394		₺1.684
T842	D063 d22 Z06 XNEX 08	63	22	6	45	0,490	XNEX 0806 SCO	₺2.036
T844	D080 d27 Z07 XNEX 08	80	27	7	50	1,063	XNEX 0806 WNST	₺2.358
T846	D100 d32 Z07 XNEX 08	100	32	7	52	1,755		₺2.405
T848	D125 d40 Z10 XNEX 08	125	40	10	60	3,155		₺3.646
T850	D160 d40 Z12 XNEX 08	160	40	12	63	5,154		₺4.611
T851	D200 d60 Z14 XNEX 08	200	60	14	63	6,415		₺6.148
		TC076 M4x12,5	T15					

SCO-WNST Ucuna Uygunur.

90° WNGX 0806

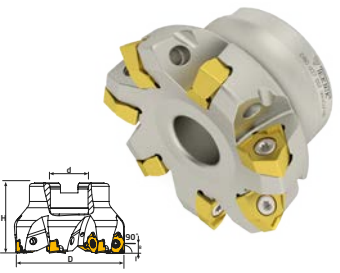

Sipariş Kodu	Ürün Kodu	Ölçüler (mm)					Uç	Fiyat
		D	d	Z	H	kg		
T775	D050 d22 Z05 WNGX 08	50	22	5	40	0,277		₺1.684
T776	D063 d22 Z06 WNGX 08	63	22	6	40	0,470	WNGX 0806	₺2.036
T777	D080 d27 Z07 WNGX 08	80	27	7	50	1,105	KRLY	₺2.358
T778	D100 d32 Z08 WNGX 08	100	32	8	52	1,580		₺2.729
		TC083 M5x12	T20					

KRLY Ucuna Uygunur.

90° WNGX 0403

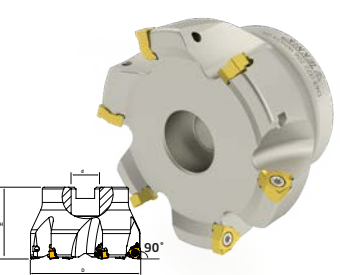

Sipariş Kodu	Ürün Kodu	Ölçüler (mm)					Uç	Fiyat
		D	d	Z	H	kg		
T692	D040 d16 Z06 WNGX 04	40	16	6	40	0,256		₺2.036
T693	D050 d22 Z08 WNGX 04	50	22	8	40	0,347	WNGX 0403	₺2.535
T694	D063 d22 Z10 WNGX 04	63	22	10	40	0,617	KRLY	₺3.169
T695	D080 d27 Z11 WNGX 04	80	27	11	50	1,306		₺3.413
		TC060 M2,5x5,5	T8					

KRLY Ucuna Uygunur.

90° WNMU 0705

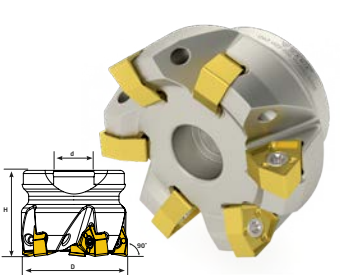

Sipariş Kodu	Ürün Kodu	Ölçüler (mm)					Uç	Fiyat
		D	d	Z	H	kg		
T392	D050 d22 Z05 WNMU 07	50	22	5	40	0,337		₺1.684
T393	D063 d22 Z06 WNMU 07	63	22	6	40	0,515	WNMU 0705	₺2.036
T394	D080 d27 Z07 WNMU 07	80	27	7	50	1,012	ISC	₺2.358
T395	D100 d32 Z08 WNMU 07	100	32	8	50	1,342		₺2.729
		TC074 M4x10	T15					

ISC Ucuna Uygunur.

90° WNMU 0806

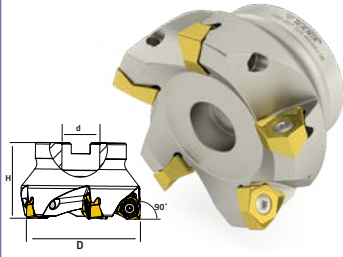

Sipariş Kodu	Ürün Kodu	Ölçüler (mm)					Uç	Fiyat
		D	d	Z	H	kg		
T543	D050 d22 Z03 WNMU 08	50	22	3	46	0,360		₺1.143
T544	D063 d22 Z04 WNMU 08	63	22	4	46	0,556	WNMU 0806	₺1.350
T545	D080 d27 Z05 WNMU 08	80	27	5	50	1,016	KYCRA	₺1.684
T546	D100 d32 Z06 WNMU 08	100	32	6	50	1,360		₺2.060
		TC083 M5x12		T20				

KYCRA Ucuna Uygundur.

88° SNMX 1206

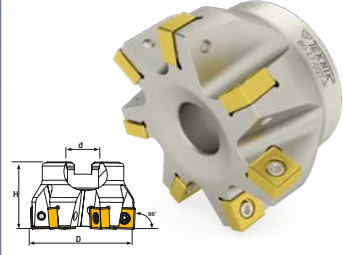

Sipariş Kodu	Ürün Kodu	Ölçüler (mm)					Uç	Fiyat
		D	d	Z	H	kg		
T344	D063 d22 Z06 SNMX 12	63	22	6	40	0,574		₺2.036
T345	D080 d27 Z07 SNMX 12	80	27	7	50	1,213	SNMX 1206	₺2.358
T346	D100 d32 Z08 SNMX 12	100	32	8	50	1,688	KRLY	₺2.729
		TC076 M4x12,5		T15				

KRLY Ucuna Uygundur.

88° SNHU 1206

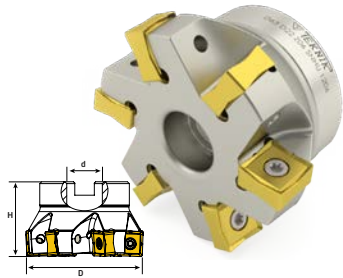

Sipariş Kodu	Ürün Kodu	Ölçüler (mm)					Uç	Fiyat
		D	d	Z	H	kg		
T617	D050 d22 Z05 SNHU 12	50	22	5	40	0,305		₺1.440
T618	D063 d22 Z06 SNHU 12	63	22	6	40	0,503	SNHU 1206	₺2.036
T619	D080 d27 Z07 SNHU 12	80	27	7	50	1,076	PLBT	₺2.358
T620	D100 d32 Z08 SNHU 12	100	32	8	50	1,459		₺2.729
T621	D125 d40 Z10 SNHU 12	125	40	10	63	2,708		₺3.646
T622	D160 d40 Z12 SNHU 12	160	40	12	63	4,328		₺4.660
		TC074 M4x10		T15				

PLBT Ucuna Uygundur

90° SPMT 1204

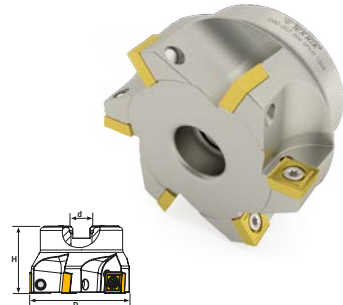

Sipariş Kodu	Ürün Kodu	Ölçüler (mm)					Uç	Fiyat
		D	d	Z	H	kg		
T649	D040 d16 Z03 SPMT 12	40	16	3	40	0,253		₺893
T650	D050 d22 Z04 SPMT 12	50	22	4	40	0,362		₺1.143
T651	D063 d22 Z05 SPMT 12	63	22	5	50	0,772		₺1.440
T652	D080 d27 Z06 SPMT 12	80	27	6	50	1,186	SPMT 1204	₺1.684
T653	D100 d32 Z08 SPMT 12	100	32	8	50	1,786		₺2.281
T654	D125 d40 Z08 SPMT 12	125	40	8	63	2,935		₺2.558
T655	D160 d40 Z10 SPMT 12	160	40	10	63	3,980		₺3.646
		TC083 M5x12		T20				

PLBT-ZCC-WLTR Ucuna Uygundur.

90° SPMG 0904

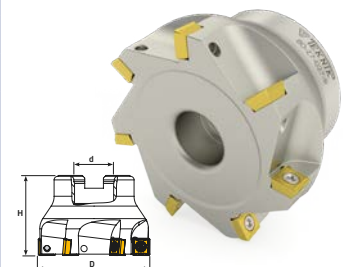

Sipariş Kodu	Ürün Kodu	Ölçüler (mm)					Uç	Fiyat
		D	d	Z	H	kg		
T338	D050 d22 Z05 SPMG 09	50	22	5	45	0,239	SPMG 0904	₺1.440
T340	D063 d22 Z06 SPMG 09	63	22	6	45	0,362	TGTC	₺1.684
T342	D080 d27 Z07 SPMG 09	80	27	7	52	1,088		₺1.934
		TC067 M3,5x8,5		T15				

TGTC Ucuna Uygundur.

90° LNMX 1006

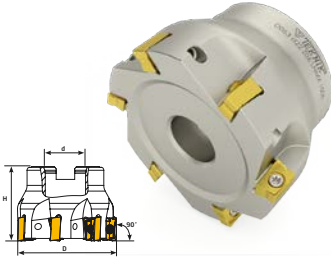

KRLY Ucuna Uygundur.

Sipariş Kodu	Ürün Kodu	Ölçüler (mm)					Uç	Fiyat
		D	d	Z	H	kg		
T386	D040 d16 Z05 LNMX 10	40	16	5	40	0,258		₺1.684
T387	D050 d22 Z06 LNMX 10	50	22	6	45	0,472	LNMX 1006	₺2.036
T388	D063 d22 Z06 LNMX 10	63	22	6	45	0,495	KRLY	₺2.036
T389	D080 d27 Z07 LNMX 10	80	27	7	50	0,731		₺2.358
T390	D100 d32 Z09 LNMX 10	100	32	9	50	1,700		₺3.023
		TC065 M3x7		T8				

90° LNMX 1510

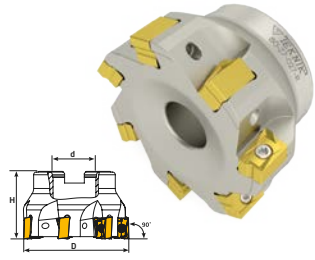

KRLY ucuna uygundur.

Sipariş Kodu	Ürün Kodu	Ölçüler (mm)					Uç	Fiyat
		D	d	Z	H	kg		
T372	D050 d22 Z04 LNMX 15	50	22	4	45	0,375		₺1.350
T374	D063 d22 Z06 LNMX 15	63	22	6	45	0,616		₺2.036
T376	D080 d27 Z07 LNMX 15	80	27	7	50	1,087	LNMX 1510	₺2.358
T378	D100 d32 Z08 LNMX 15	100	32	8	52	1,644	KRLY	₺2.729
T380	D125 d40 Z10 LNMX 15	125	40	10	63	3,650		₺3.646
		TC076 M4x12,5		T15				

90° ANKX 1205

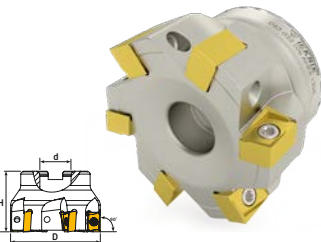

ISCR Ucuna Uygundur.

Sipariş Kodu	Ürün Kodu	Ölçüler (mm)					Uç	Fiyat
		D	d	Z	H	kg		
T571	D040 d16 Z04 ANKX 12	40	16	4	40	0,215		₺1.350
T572	D050 d22 Z05 ANKX 12	50	22	5	45	0,433	ANKX 1205	₺1.684
T574	D063 d22 Z06 ANKX 12	63	22	6	45	0,596	ISCR	₺2.036
T576	D080 d27 Z07 ANKX 12	80	27	7	50	1,210		₺2.358
		TC074 M4x10		T15				

90° ANKX 1706

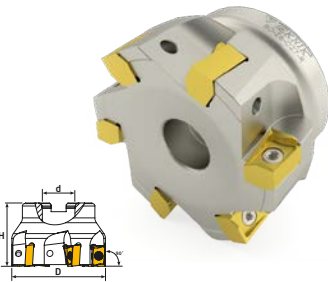

ISCR Ucuna Uygundur.

Sipariş Kodu	Ürün Kodu	Ölçüler (mm)					Uç	Fiyat
		D	d	Z	H	kg		
T440	D040 d16 Z03 ANKX 17	40	16	3	45	0,279		₺1.143
T442	D050 d22 Z04 ANKX 17	50	22	4	45	0,371	ANKX 1706	₺1.350
T444	D063 d22 Z05 ANKX 17	63	22	5	45	0,573	ISCR	₺1.684
T446	D080 d27 Z06 ANKX 17	80	27	6	52	1,238		₺2.036
T448	D100 d32 Z07 ANKX 17	100	32	7	52	2,029		₺2.405
T450	D125 d40 Z08 ANKX 17	125	40	8	63	3,590		₺2.974
		TC083 M5x12		T20				

90° ANHX 1004

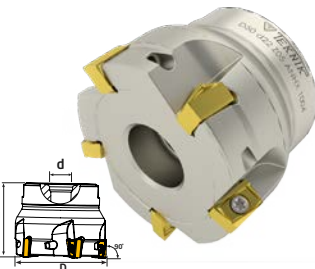

PLBT Ucuna Uygundur.

Sipariş Kodu	Ürün Kodu	Ölçüler (mm)					Uç	Fiyat
		D	d	Z	H	kg		
T656	D040 d16 Z04 ANHX 10	40	16	4	40	0,250		₺1.350
T657	D050 d22 Z05 ANHX 10	50	22	5	40	0,374	ANHX 1004	₺1.684
T658	D063 d22 Z07 ANHX 10	63	22	7	40	0,638	PLBT	₺2.340
T659	D080 d27 Z08 ANHX 10	80	27	8	50	1,132		₺2.658
		TC065 M3x7		T8				

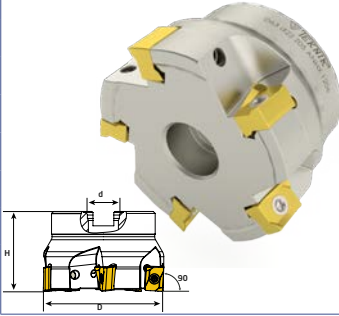
90° ANHX 1206

PLBT Ucuna Uygundur.

Sipariş Kodu	Ürün Kodu	Ölçüler (mm)					Uç	Fiyat
		D	d	Z	H	kg		
T641	D040 d16 Z04 ANHX 12	40	16	4	40	0,248		₺1.350
T642	D050 d22 Z05 ANHX 12	50	22	5	40	0,375		₺1.684
T643	D063 d22 Z05 ANHX 12	63	27	5	40	0,619	ANHX 1206	₺1.684
T644	D080 d27 Z08 ANHX 12	80	27	8	50	1,209	PLBT	₺2.629
T645	D100 d32 Z12 ANHX 12	100	32	12	50	1,761		₺3.894
T646	D125 d40 Z14 ANHX 12	125	40	14	63	3,091		₺4.514

 TC069 M3,5x8,5

 T10

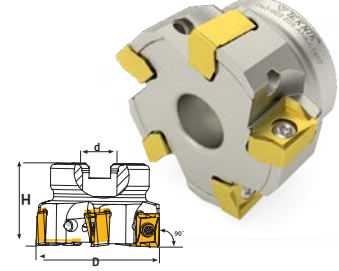
90° ANKX 1607

XTC- GSC Ucuna Uygundur

Sipariş Kodu	Ürün Kodu	Ölçüler (mm)					Uç	Fiyat
		D	d	Z	H	kg		
T171	D050 d22 Z04 ANKX 16	50	22	4	40	0,307		₺1.350
T172	D063 d22 Z05 ANKX 16	63	22	5	40	0,462	ANKX 1607	₺1.684
T173	D080 d27 Z06 ANKX 16	80	27	6	50	1,101		₺2.036

 TC080-1 M4,5x11

 T15

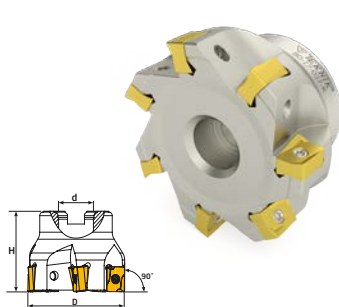
90° LNGX 1307

WLTR Ucuna Uygundur.

Sipariş Kodu	Ürün Kodu	Ölçüler (mm)					Uç	Fiyat
		D	d	Z	H	kg		
T488	D040 d16 Z03 LNGX 13	40	16	3	45	0,304		₺1.143
T490	D050 d22 Z04 LNGX 13	50	22	4	45	0,425		₺1.350
T492	D063 d22 Z06 LNGX 13	63	22	6	45	0,560	LNGX 1307	₺2.036
T493	D080 d27 Z07 LNGX 13	80	27	7	50	1,124	WLTR	₺2.358
T494	D100 d32 Z07 LNGX 13	100	32	7	50	1,542		₺2.405
T495	D125 d40 Z08 LNGX 13	125	40	8	63	3,555		₺3.024

 TC079 M4x10

 T15

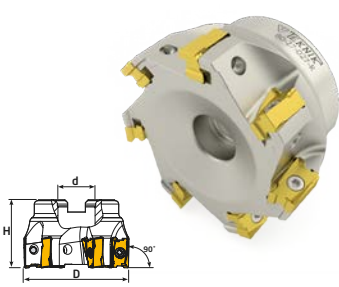
90° LNGU 15T6

KNNMTL Ucuna Uygundur

Sipariş Kodu	Ürün Kodu	Ölçüler (mm)					Uç	Fiyat
		D	d	Z	H	kg		
T956	D050 d22 Z05 LNGU 15	50	22	5	40	0,305		₺1.684
T958	D063 d22 Z06 LNGU 15	63	22	6	40	0,541	LNGU 15T6	₺2.036
T960	D080 d27 Z07 LNGU 15	80	27	7	50	1,133	KNNMTL	₺2.405
T961	D100 d32 Z08 LNGU 15	100	32	8	50	1,933		₺2.729

 TC074 M4x10

 T15

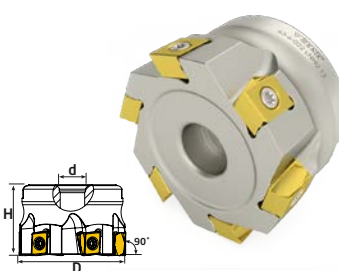
90° LNHU 1306

WLTR Ucuna Uygundur.

Sipariş Kodu	Ürün Kodu	Ölçüler (mm)					Uç	Fiyat
		D	d	Z	H	kg		
T580	D050 d22 Z05 LNHU 13	50	22	5	40	0,350		₺1.440
T581	D063 d22 Z06 LNHU 13	63	22	6	40	0,628	LNHU 1306	₺1.884
T582	D080 d27 Z07 LNHU 13	80	27	7	50	1,315	WLTR	₺2.333
T583	D100 d32 Z08 LNHU 13	100	32	8	50	1,795		₺2.531

 TC079 M4x10

 T15

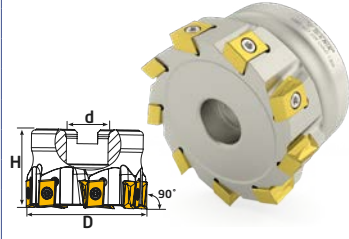

90° LNMT 1306



Sipariş Kodu	Ürün Kodu	Ölçüler (mm)					Uç	Fiyat
		D	d	Z	H	kg		
T228	D050 d22 Z05 LNMT 13	50	22	5	40	0,337		₺1.440
T229	D063 d22 Z06 LNMT 13	63	22	6	40	0,596	LNMT 1306	₺1.934
T230	D080 d27 Z07 LNMT 13	80	27	7	50	1,227	ISCR	₺2.405
T231	D100 d32 Z08 LNMT 13	100	32	8	50	1,682		₺2.678
T232	D125 d40 Z09 LNMT 13	125	40	9	63	3,325		₺3.769
T233	D160 d40 Z12 LNMT 13	160	40	12	63	5,046		₺4.660
		TC 074 M4x10		T15				

ISCR Ucuna Uygundur.

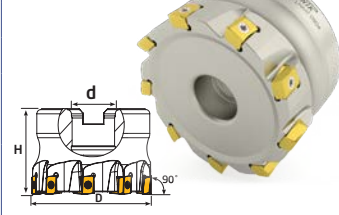
90° LNMT 0804



Sipariş Kodu	Ürün Kodu	Ölçüler (mm)					Uç	Fiyat
		D	d	Z	H	kg		
T222	D040 d16 Z06 LNMT 08	40	16	6	40	0,240		₺1.684
T223	D050 d22 Z07 LNMT 08	50	22	7	40	0,374	LNMT 0804	₺1.934
T224	D063 d22 Z09 LNMT 08	63	22	9	40	0,665	ISCR	₺2.405
T225	D080 d27 Z10 LNMT 08	80	27	10	50	1,145		₺2.678
		TC061 M2,5x6,5		T8				

ISCR Ucuna Uygundur.

90° LNXT 1306

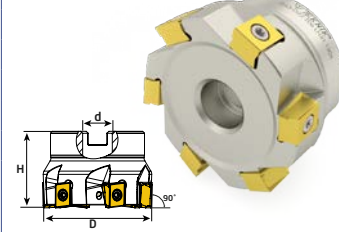

Sipariş Kodu	Ürün Kodu	Ölçüler (mm)					Uç	Fiyat
		D	d	Z	H	kg		
T672	D040 d16 Z04 LNXT 13	40	16	4	40	0,225		₺1.143
T673	D050 d22 Z05 LNXT 13	50	22	5	40	0,358	LNXT 1306	₺1.440
T674	D063 d22 Z06 LNXT 13	63	22	6	40	0,604	PLBT	₺1.684
T675	D080 d27 Z07 LNXT 13	80	27	7	50	1,029		₺1.934
T676	D100 d32 Z08 LNXT 13	100	32	8	50	1,733		₺2.281
		TC074 M4x10		T15				

PLBT Ucuna Uygundur.

90° LOEX 1207

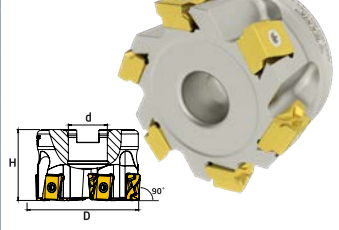

Sipariş Kodu	Ürün Kodu	Ölçüler (mm)					Uç	Fiyat
		D	d	Z	H	kg		
T586	D050 d22 Z05 LOEX12	50	22	5	40	0,358	LOEX 1207	₺1.440
T587	D063 d22 Z06 LOEX12	63	22	6	40	0,604	SCO	₺1.684
T588	D080 d27 Z08 LOEX12	80	27	8	50	1,029		₺1.934

SCO Ucuna Uygundur.

90° XNKT 0805

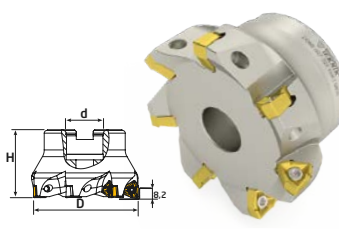

Sipariş Kodu	Ürün Kodu	Ölçüler (mm)					Uç	Fiyat
		D	d	Z	H	kg		
T900	D040 d16 Z04 XNKT 08	40	16	4	45	0,296		₺1.143
T902	D050 d22 Z05 XNKT 08	50	22	5	45	0,396	XNKT 0805	₺1.440
T904	D063 d22 Z06 XNKT 08	63	22	6	45	0,575	KRLY	₺1.684
T906	D080 d27 Z07 XNKT 08	80	27	7	50	1,015		₺1.934
T907	D100 d40 Z08 XNKT 08	100	40	8	52	1,575		₺2.281
		TC072 M4x10		T15				

KRLY Ucuna Uygundur.

90° XNKT 0604

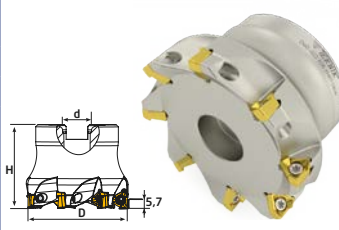

Sipariş Kodu	Ürün Kodu	Ölçüler (mm)					Uç	Fiyat
		D	d	Z	H	kg		
T852	D032 d16 Z04 XNKT 06	32	16	4	40	0,150		₺1.143
T853	D040 d16 Z06 XNKT 06	40	16	6	40	0,219	XNKT 0604	₺1.684
T854	D050 d22 Z07 XNKT 06	50	22	7	40	0,348	KRLY	₺1.934
T855	D063 d22 Z08 XNKT 06	63	22	8	40	0,527		₺2.183
T856	D080 d27 Z10 XNKT 06	80	27	10	50	0,938		₺2.729
		TC065-1M3x7		T8				

KRLY Ucuna Uygundur.

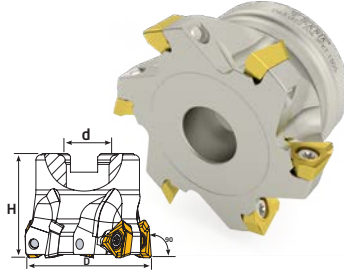
90° 3PKT 1505

TGTC Ucuna Uygunur.

Sipariş Kodu	Ürün Kodu	Ölçüler (mm)					Uç	Fiyat
		D	d	Z	H	kg		
T398	D050 d22 Z05 3PKT 15	50	22	5	40	0,325		₺1.440
T399	D063 d22 Z06 3PKT 15	63	22	6	40	0,490	3PKT 1505	₺1.684
T400	D080 d27 Z07 3PKT 15	80	27	7	50	1,105	TGTC	₺1.934

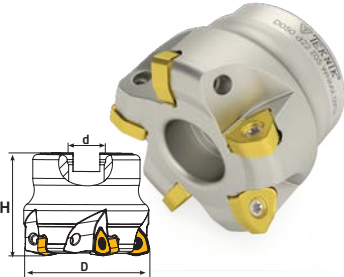
WNMX 09T3

KRLY Ucuna Uygunur.

Sipariş Kodu	Ürün Kodu	Ölçüler (mm)					Uç	Fiyat
		D	d	Z	H	kg		
T669	D040 d16 Z04 WNMX 09	40	16	4	40	0,213		₺1.350
T670	D050 d22 Z05 WNMX 09	50	22	5	40	0,329	WNMX 09T3	₺1.684
T671	D063 d22 Z06 WNMX 09	63	22	6	40	0,542	KRLY	₺2.036
T671-1	D080 d27 Z06 WNMX 09	80	27	6	50	1,077		₺2.073
T671-2	D100 d32 Z07 WNMX 09	100	32	7	50	1,627		₺2.405

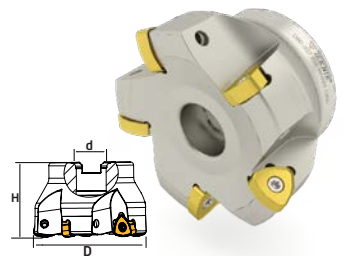
WNMX 1305

KRLY Ucuna Uygunur.

Sipariş Kodu	Ürün Kodu	Ölçüler (mm)					Uç	Fiyat
		D	d	Z	H	kg		
T687	D063 d22 Z04 WNMX 13	63	22	4	50	0,752		₺1.341
T688	D080 d27 Z05 WNMX 13	80	27	5	50	1,040	WNMX 1305	₺1.560
T689	D100 d32 Z06 WNMX 13	100	32	6	50	1,625	KRLY	₺1.865
T690	D125 d40 Z07 WNMX 13	125	40	7	63	3,716		₺2.535

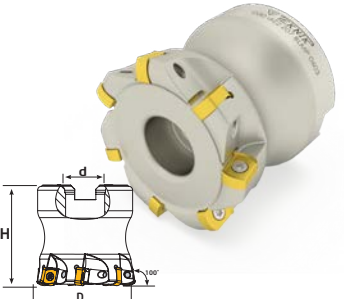
100° BLMP 0603

TGTC Ucuna Uygunur.

Sipariş Kodu	Ürün Kodu	Ölçüler (mm)					Uç	Fiyat
		D	d	Z	H	kg		
T480	D040 d16 Z06 BLMP 06	40	16	6	45	0,262	BLMP 0603	₺1.684
T481	D050 d22 Z07 BLMP 06	50	22	7	50	0,457	TGTC	₺1.934
T482	D052 d22 Z07 BLMP 06	52	22	7	50	0,472		₺1.934

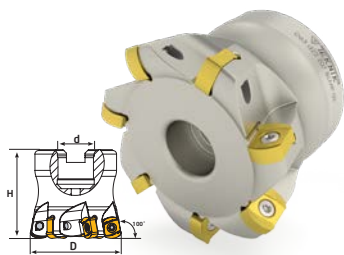
100° BLMP 0904



TGTC Ucuna Uygunur.

Sipariş Kodu	Ürün Kodu	Ölçüler (mm)					Uç	Fiyat
		D	d	Z	H	kg		
T485	D040 d16 Z05 BLMP 09	40	16	5	40	0,176		₺1.440
T486	D052 d22 Z06 BLMP 09	52	22	6	50	0,427	BLMP 0904	₺1.684
T487	D063 d22 Z07 BLMP 09	63	22	7	50	0,615	TGTC	₺1.934



Sipariş Kodu	Ürün Kodu	Ölçüler (mm)					Uç	Fiyat
		D	d	Z	H	kg		
T835	D032 d16 Z05 LNMX 06	32	16	5	40	0,173	LNMX 0603	₺1.684
T836	D040 d16 Z06 LNMX 06	40	16	6	40	0,279	KRLY	₺2.036
T837	D050 d22 Z08 LNMX 06	50	22	8	40	0,400		₺2.681
		TC065-1 M3x7		T8				

KRLY Ucuna Uygundur.

Sipariş Kodu	Ürün Kodu	Ölçüler (mm)					Uç	Fiyat
		D	d	Z	H	kg		
T763	D040 d16 Z06 ENMX 06	40	16	6	40	0,261	ENMX 0604	₺2.036
T764	D050 d22 Z06 ENMX 06	50	22	6	50	0,478	YG1	₺2.060
T765	D063 d22 Z07 ENMX 06	63	22	7	50	0,762		₺2.719
		TC063 M2,5x7		T8				

YG1 Ucuna Uygundur.

Sipariş Kodu	Ürün Kodu	Ölçüler (mm)					Uç	Fiyat
		D	d	Z	H	kg		
T701	D050 d22 Z04 ENMX 09	50	22	4	50	0,487		₺1.350
T702	D063 d22 Z05 ENMX 09	63	22	5	50	0,796	ENMX 0905	₺1.684
T703	D080 d27 Z08 ENMX 09	80	27	8	50	1,188	YG1	₺2.658
T704	D100 d32 Z10 ENMX 09	100	32	10	63	2,867		₺3.291
T705	D125 d40 Z12 ENMX 09	125	40	12	63	4,186		₺3.949
		TC069 M3,5x8,5		T10				

YG1 Ucuna Uygundur.

Sipariş Kodu	Ürün Kodu	Ölçüler (mm)					Uç	Fiyat
		D	d	Z	H	kg		
T728	D040 d16 Z06 LNMU 03	40	16	6	40	0,275	LNMU 0303	₺2.036
T729	D050 d22 Z07 LNMU 03	50	22	7	50	0,541	TNGLY - OKE	₺2.681
T730	D063 d22 Z09 LNMU 03	63	22	9	50	0,766		₺3.169
		TC063 M2,5x7		T8				



TNGLY-OKE Ucuna Uygundur.

Sipariş Kodu	Ürün Kodu	Ölçüler (mm)					Uç	Fiyat
		D	d	Z	H	kg		
T731	D040 d16 Z06 LOGU 03	40	16	6	40	0,283	LOGU 0303	₺2.036
T732	D050 d22 Z07 LOGU 03	50	22	7	50	0,582	KYCR	₺2.681
T734	D063 d22 Z09 LOGU 03	63	22	9	50	1,188		₺3.169
		TC064-2 M3x7		T8				

KYCR Ucuna Uygundur.

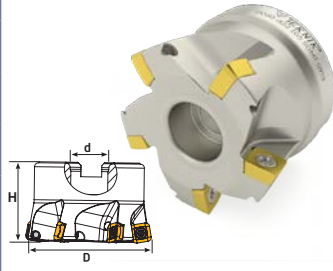
SDMT 09T3





Sipariş Kodu	Ürün Kodu	Ölçüler (mm)					Uç	Fiyat
		D	d	Z	H	kg		
T362	D040 d16 Z04 SDMT 09	40	16	4	40	0,215	SDMT 09T3	₺1.143
T363	D050 d22 Z05 SDMT 09	50	22	5	40	0,355	ZCC	₺1.440
T364	D063 d22 Z06 SDMT 09	63	22	6	40	0,592		₺1.684
		 TC067 M3,5x8,5		 T15				

ZCC Ucuna Uygunur.

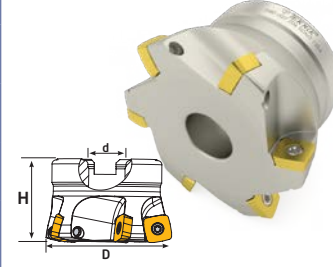
SDMT 1204





Sipariş Kodu	Ürün Kodu	Ölçüler (mm)					Uç	Fiyat
		D	d	Z	H	kg		
T358	D050 d22 Z04 SDMT 12	50	22	4	40	0,315	SDMT 1204	₺1.143
T359	D063 d22 Z05 SDMT 12	63	22	5	40	0,422	ZCC	₺1.440
T360	D080 d27 Z06 SDMT 12	80	27	6	52	1,051		₺1.684
		 TC074 M4x10		 T15				

ZCC Ucuna Uygunur.

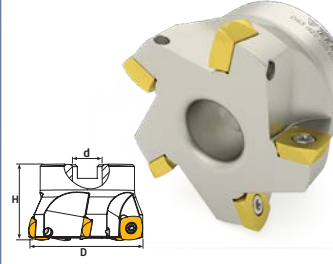
ZDEW 1204





Sipariş Kodu	Ürün Kodu	Ölçüler (mm)					Uç	Fiyat
		D	d	Z	H	kg		
T196	D050 d22 Z04 ZDEW 12	50	22	4	40	0,256	ZDEW 1204	₺1.241
T197	D063 d22 Z05 ZDEW 12	63	22	5	40	0,474	PRMT	₺1.586
		 TC080-1M4,5x11		 T15				

PRMT Ucuna Uygunur.

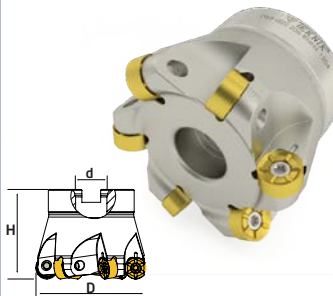
RNHX 1204





Sipariş Kodu	Ürün Kodu	Ölçüler (mm)					Uç	Fiyat
		D	d	Z	H	kg		
T661	D050 d22 Z05 RNHX 12	50	22	5	40	0,284	RNHX 1204	₺1.684
T662	D063 d22 Z06 RNHX 12	63	22	6	50	0,637	PLBT	₺2.036
T664	D100 d32 Z08 RNHX 12	100	32	8	50	1,570		₺2.730
		 TC074 M4x10		 T15				

PLBT Ucuna Uygunur.

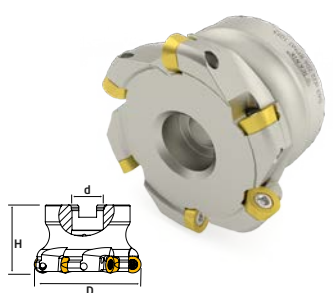
RPMW 10T3



Sipariş Kodu	Ürün Kodu	Ölçüler (mm)					Uç	Fiyat
		D	d	Z	H	kg		
T706	D040 d16 Z05 RPMW 10	40	16	5	40	0,240		₺1.440
T707	D050 d22 Z06 RPMW 10	50	22	6	40	0,359	RPMW 10T3	₺1.684
T708	D063 d22 Z06 RPMW 10	63	22	6	40	0,584	KRLY	₺1.684
T709	D080 d27 Z07 RPMW 10	80	27	7	50	1,272		₺1.935
		 TC067 M3,5x8,5		 T15				

KRLY Ucuna Uygunur.

RPMW 1204

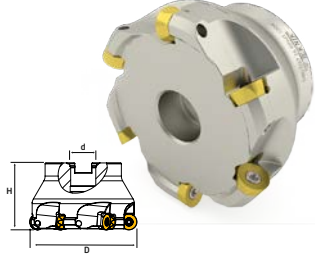

Sipariş Kodu	Ürün Kodu	Ölçüler (mm)					Uç	Fiyat
		D	d	Z	H	kg		
T711	D050 d22 Z05 RPMW 12	50	22	5	40	0,327		₺1.440
T712	D063 d22 Z05 RPMW 12	63	22	5	40	0,556	RPMW 1204	₺1.440
T713	D080 d27 Z06 RPMW 12	80	27	6	50	0,584	KRLY	₺1.684
T714	D100 d32 Z07 RPMW 12	100	32	7	53	1,278		₺2.011
		TC073 M4x8,5		T15 2,027				

KRLY Ucuna Uygundur.

RPMW 1606

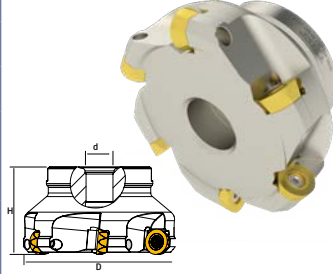

Sipariş Kodu	Ürün Kodu	Ölçüler (mm)					Uç	Fiyat
		D	d	Z	H	kg		
T717	D063 d22 Z05 RPMW 16	63	22	5	40	0,509		₺1.440
T718	D080 d27 Z06 RPMW 16	80	27	6	50	1,048	RPMW 1606	₺1.684
T719	D100 d32 Z07 RPMW 16	100	32	7	55	0,584	KRLY	₺2.011
T720	D125 d40 Z08 RPMW 16	125	40	8	63	1,903		₺2.316
		TC083 M5X12		T20 3,775				

KRLY Ucuna Uygundur.

RDMT 1003

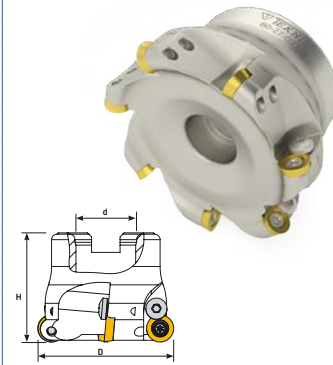

Sipariş Kodu	Ürün Kodu	Ölçüler (mm)					Uç	Fiyat
		D	d	Z	H	kg		
T288	D040 d16 Z03 RDMT 10	40	16	3	40	0,208		₺893
T289	D040 d16 Z04 RDMT 10	40	16	4	40	0,220		₺1.143
T290	D050 d22 Z04 RDMT 10	50	22	4	40	0,310		₺1.143
T291	D050 d22 Z05 RDMT 10	50	22	5	40	0,302	RDMT 1003	₺1.440
T292	D063 d22 Z05 RDMT 10	63	22	5	40	0,445	ISO	₺1.440
T293	D063 d22 Z06 RDMT 10	63	22	6	40	0,460		₺1.684
T294	D080 d27 Z06 RDMT 10	80	27	6	50	1,033		₺1.684
T294-1	D080 d27 Z07 RDMT 10	80	27	7	50	1,048		₺1.934
T295	D100 d32 Z07 RDMT 10	100	32	7	50	1,463		₺2.009
T295-1	D100 d32 Z08 RDMT 10	100	32	8	50	1,478		₺2.281
		TC040 M3,5		TC040 M3,5		T15		

RDMT 12T3

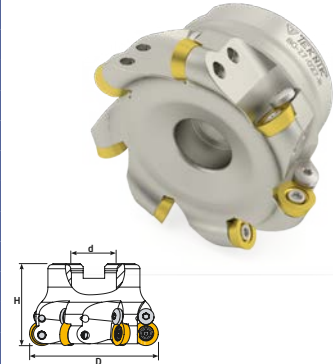

Sipariş Kodu	Ürün Kodu	Ölçüler (mm)					Uç	Fiyat
		D	d	Z	H	kg		
T280	D040 d16 Z03 RDMT 12	40	16	3	40	0,235		₺893
T281	D040 d16 Z04 RDMT 12	40	16	4	40	0,236		₺1.143
T282	D050 d22 Z04 RDMT 12	50	22	4	40	0,311		₺1.143
T283	D050 d22 Z05 RDMT 12	50	22	5	40	0,309	RDMT 12T3	₺1.440
T284	D063 d22 Z05 RDMT 12	63	22	5	40	0,468	ISO	₺1.440
T285	D063 d22 Z06 RDMT 12	63	22	6	40	0,500		₺1.684
T286	D080 d27 Z06 RDMT 12	80	27	6	50	0,925		₺1.684
T286-1	D080 d27 Z07 RDMT 12	80	27	7	50	0,950		₺1.934
T287	D100 d32 Z07 RDMT 12	100	32	7	50	1,402		₺2.009
T287-1	D100 d32 Z08 RDMT 12	100	32	8	50	1,435		₺2.281
		TC067 M3,5X8,5		TC040 M3,5		T15		

RDMT 1604

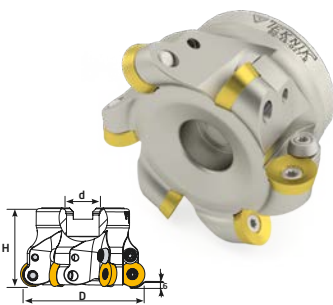



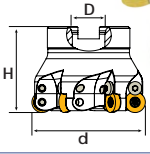

Sipariş Kodu	Ürün Kodu	Ölçüler (mm)					Uç	Fiyat	
		D	d	Z	H	kg			
T270	D050 d22 Z04 RDMT 16	50	22	4	50	0,350		₺1.143	
T271	D052 d22 Z04 RDMT 16	52	22	4	50	0,350	RDMT 1604	₺1.143	
T273	D063 d22 Z05 RDMT 16	63	22	5	45	0,512	ISO	₺1.440	
T272	D066 d27 Z05 RDMT 16	66	27	5	50	0,495		₺1.440	
T274	D080 d27 Z06 RDMT 16	80	27	6	50	0,890		₺1.684	
T275	D100 d32 Z07 RDMT 16	100	32	7	52	1,370		₺2.036	
		TC074 M4x10		BK035		TC080 M4,5x11		T15	

RDMT 12T3



Sipariş Kodu	Ürün Kodu	Ölçüler (mm)					Uç	Fiyat
		D	d	Z	H	kg		
T667	D052 d22 Z05 RDMT 12	52	22	5	50	0,403	RDMT 12T3	₺1.440
T668-1	D066 d27 Z06 RDMT 12	66	27	6	50	0,670	PLBT	₺1.684
T668	D080 d27 Z07 RDMT 12	80	27	7	50	1,181		₺1.934







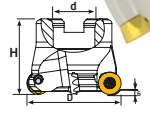

PLBT Ucuna Uygundur.

RCKT 1204



Sipariş Kodu	Ürün Kodu	Ölçüler (mm)					Uç	Fiyat
		D	d	Z	H	kg		
T460	D050 d22 Z04 RCKT 12	50	22	4	40	0,287		₺1.143
T462	D063 d22 Z05 RCKT 12	63	22	5	40	0,436	RCKT 1204	₺1.440
T464	D080 d27 Z06 RCKT 12	80	27	6	50	1,088	SNDVK	₺1.684
T466	D100 d32 Z07 RCKT 12	100	32	7	52	1,608		₺2.036







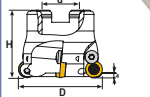

SNDVK Ucuna Uygundur.

RHKW 0802



Sipariş Kodu	Ürün Kodu	Ölçüler (mm)					Uç	Fiyat
		D	d	Z	H	kg		
T599	D040 d16 Z04 RHKW 08	40	16	4	40	0,247	RHKW 0802	₺1.143
T600	D050 d22 Z05 RHKW 08	50	22	5	40	0,309	INGRSLL	₺1.440
T601	D063 d22 Z06 RHKW 08	63	22	6	40	0,530		₺1.684







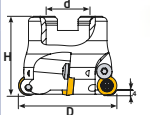

INGRSLL Ucuna Uygundur.

RHKW 1003



Sipariş Kodu	Ürün Kodu	Ölçüler (mm)					Uç	Fiyat
		D	d	Z	H	kg		
T602	D040 d16 Z04 RHKW 10	40	16	4	40	0,243	RHKW 1003	₺1.143
T604	D050 d22 Z05 RHKW 10	50	22	5	40	0,289	INGRSLL	₺1.440
T606	D063 d22 Z06 RHKW 10	63	22	6	40	0,488		₺1.684
T608	D080 d27 Z07 RHKW 10	80	27	7	50	1,080		₺1.934







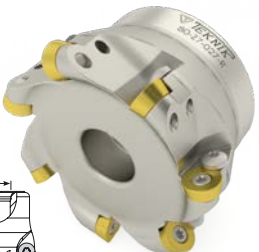
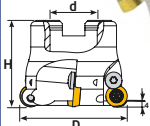

INGRSLL Ucuna Uygundur.

RHKW 1204



Sipariş Kodu	Ürün Kodu	Ölçüler (mm)					Uç	Fiyat
		D	d	Z	H	kg		
T612	D040 d16 Z04 RHKW 12	40	16	4	40	0,246	RHKW 1204	₺1.143
T613	D050 d22 Z05 RHKW 12	50	22	5	40	0,304	INGRSLL	₺1.440
T614	D063 d22 Z06 RHKW 12	63	22	6	40	0,556		₺1.684
T615	D080 d27 Z07 RHKW 12	80	27	7	50	1,039		₺1.934

INGRSLL Ucuna Uygundur.

90° APMT 0602

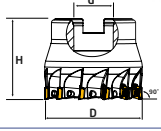

Sipariş Kodu	Ürün Kodu	Ölçüler (mm)					Uç	Fiyat
		D	d	Z	H	kg		
T596	D40 d16 Z10 APMT 06	40	16	10	40	0,281	APMT 0602	₺3.048
T597	D50 d22 Z12 APMT 06	50	22	12	40	0,435	KRLY	₺3.656
T598	D63 d22 Z14 APMT 06	63	22	14	40	0,715		₺4.023
T239	D40 d16 Z05 APMT 09	40	16	5	40	0,248	APMT 0602	₺1.440
T240	D50 d22 Z06 APMT 09	50	22	6	40	0,348	KRLY	₺1.684
Kod								
T596-T598		TC057-1 M1,8x4,1		T6				
T239-T240		TC060 M2,5x5,5		T8				

KRLY Ucuna Uygundur.

90° APMT 11T3

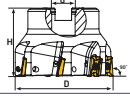

Sipariş Kodu	Ürün Kodu	Ölçüler (mm)					Uç	Fiyat
		D	d	Z	H	kg		
T250	D040 d16 Z05 APMT 11	40	16	5	40	0,220		₺1.440
T252	D050 d22 Z06 APMT 11	50	22	6	40	0,332	APMT 11T3	₺1.684
T254	D063 d22 Z07 APMT 11	63	22	7	40	0,483	KRLY	₺1.934
T256	D080 d27 Z08 APMT 11	80	27	8	50	1,115		₺2.231
T258	D100 d32 Z10 APMT 11	100	32	10	63	1,810		₺2.729
		TC060 M2,5x5,5		T8				

KRLY Ucuna Uygundur.

90° APMT 1604

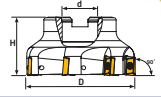

Sipariş Kodu	Ürün Kodu	Ölçüler (mm)					Uç	Fiyat
		D	d	Z	H	kg		
T241	D040 d16 Z04 APMT 16	40	16	4	45	0,258		₺1.143
T243	D050 d22 Z05 APMT 16	50	22	5	45	0,400	APMT 1604	₺1.440
T245	D063 d22 Z06 APMT 16	63	22	6	45	0,578	KRLY	₺1.684
T247	D080 d27 Z07 APMT 16	80	27	7	52	1,249		₺1.934
T249	D100 d32 Z08 APMT 16	100	32	8	52	1,530		₺2.281
		TC074 M4x10		T15				

KRLY Ucuna Uygundur.

90° APKT 1604

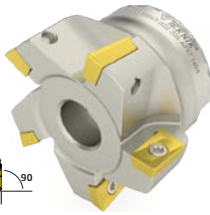
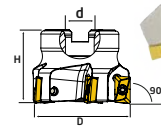

Sipariş Kodu	Ürün Kodu	Ölçüler (mm)					Uç	Fiyat
		D	d	Z	H	kg		
T767	D050 d22 Z04 APKT 16	50	22	4	45	0,381	APKT 1604	₺1.143
T768	D063 d22 Z05 APKT 16	63	22	5	45	0,507	YG1	₺1.440
T769	D080 d27 Z06 APKT 16	80	27	6	52	1,125		₺1.684
		TC074 M4x10		T15				

YG1 ucuna uygundur.

90° APKT 1604

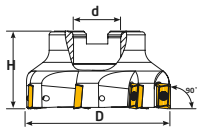



Sipariş Kodu	Ürün Kodu	Ölçüler (mm)					Uç	Fiyat
		D	d	Z	H	kg		
T180	D040 d16 Z03 APKT 16	40	16	3	45	0,267		₺893
T181	D040 d16 Z04 APKT 16	40	16	4	45	0,258		₺1.143
T182	D050 d22 Z04 APKT 16	50	22	4	45	0,406		₺1.143
T183	D050 d22 Z05 APKT 16	50	22	5	45	0,400		₺1.440
T184	D063 d22 Z05 APKT 16	63	22	5	45	0,577		₺1.440
T185	D063 d22 Z06 APKT 16	63	22	6	45	0,578	APKT 1604	₺1.684
T186	D080 d27 Z06 APKT 16	80	27	6	52	1,159	KRLY	₺1.684
T187	D080 d27 Z07 APKT 16	80	27	7	52	1,249		₺1.934
T188	D100 d32 Z07 APKT 16	100	32	7	52	1,057		₺1.983
T189	D100 d32 Z08 APKT 16	100	32	8	52	1,530		₺2.281
T190	D125 d40 Z09 APKT 16	125	40	9	62	3,642		₺2.876
T192	D160 d40 Z10 APKT 16	160	40	10	62	4,885		₺3.646
T193	D200 d60 Z12 APKT 16	200	60	12	63	6,370		₺5.209
T195	D300 d60 Z15 APKT 16	300	60	15	62	14,360		₺9.220
		TC074 M4x10		T15				

KRLY Ucuna Uygundur.

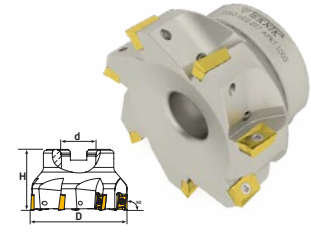
90° APXT 1003





KRLY Ucuna Uygun.

Sipariş Kodu	Ürün Kodu	Ölçüler (mm)					Uç	Fiyat
		D	d	Z	H	kg		
T176	D040 d16 Z05 APXT 10	40	16	5	40	0,277		₺1.440
T177	D050 d22 Z06 APXT 10	50	22	6	40	0,398	APXT 1003	₺1.684
T178	D063 d22 Z07 APXT 10	63	22	7	40	0,543	KRLY	₺1.934
T179	D080 d27 Z08 APXT 10	80	27	8	50	1,205		₺2.231
		 TC060 M2,5x5,5		 T8				

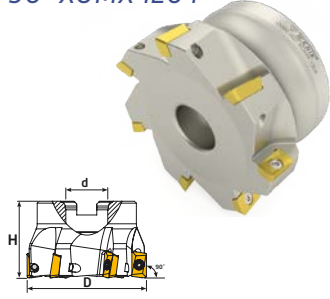
90° XOMX 1204





SCO Ucuna Uygun.

Sipariş Kodu	Ürün Kodu	Ölçüler (mm)					Uç	Fiyat
		D	d	Z	H	kg		
T510	D040 d16 Z04 XOMX 12	40	16	4	40	0,250		₺1.143
T512	D050 d22 Z05 XOMX 12	50	22	5	40	0,351		₺1.440
T514	D063 d22 Z06 XOMX 12	63	22	6	40	0,618	XOMX 1204	₺1.684
T516	D080 d27 Z07 XOMX 12	80	27	7	50	1,155	SCO	₺1.934
T518	D100 d32 Z10 XOMX 12	100	32	10	52	1,817		₺2.729
T519	D125 d40 Z12 XOMX 12	125	40	12	62	3,565		₺3.373
		 TC069 M3,5x8,5		 T10				

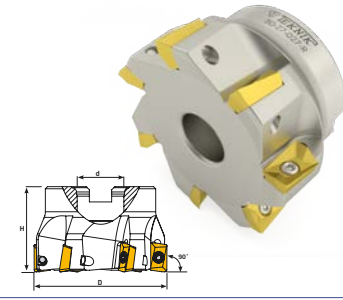
90° XOMX 1806





SCO Ucuna Uygun.

Sipariş Kodu	Ürün Kodu	Ölçüler (mm)					Uç	Fiyat
		D	d	Z	H	kg		
T520	D050 d22 Z05 XOMX 18	50	22	5	45	0,337		₺1.440
T522	D063 d22 Z06 XOMX 18	63	22	6	45	0,550		₺1.684
T524	D080 d27 Z07 XOMX 18	80	27	7	50	1,082	XOMX 1806	₺1.934
T525	D100 d32 Z08 XOMX 18	100	32	8	52	1,661	SCO	₺2.281
T526	D125 d40 Z09 XOMX 18	125	40	9	62	3,427		₺2.876
T527	D160 d40 Z10 XOMX 18	160	40	10	62	4,831		₺3.646
		 TC080 M4,5x11		 T15				

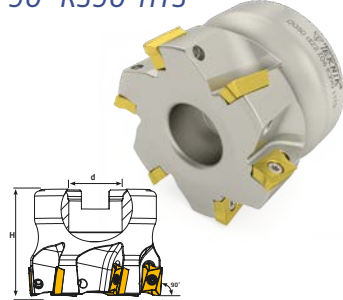
90° R390-11T3





SNDVK Ucuna Uygun.

Sipariş Kodu	Ürün Kodu	Ölçüler (mm)					Uç	Fiyat
		D	d	Z	H	kg		
T577	D040 d16 Z05 R390 11	40	16	5	40	0,225	R390-11T3	₺1.440
T578	D050 d22 Z06 R390 11	50	22	6	40	0,355	SNDVK	₺1.684
T579	D063 d22 Z07 R390 11	63	22	7	40	0,503		₺1.934
		 TC063 M2,5x7		 T8				

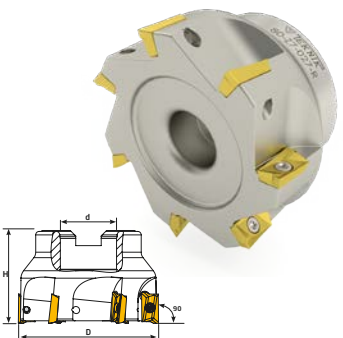
90° R390-1704



SNDVK Ucuna Uygun.

Sipariş Kodu	Ürün Kodu	Ölçüler (mm)					Uç	Fiyat
		D	d	Z	H	kg		
T402	D040 d16 Z04 R390 17	40	16	4	45	0,276		₺1.143
T404	D050 d22 Z05 R390 17	50	22	5	45	0,591		₺1.440
T408	D063 d22 Z06 R390 17	63	22	6	45	0,590	R390-1704	₺1.684
T411	D080 d27 Z07 R390 17	80	27	7	52	1,168	SNDVK	₺1.934
T412	D100 d32 Z08 R390 17	100	32	8	52	1,665		₺2.281
T414	D125 d40 Z09 R390 17	125	40	9	62	3,680		₺2.876
T416	D160 d40 Z10 R390 17	160	40	10	62	5,010		₺3.646
		 TC067 M3,5x8,5		 T15				

90° R390-1806

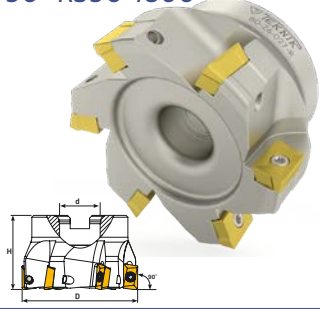

SNDVK Ucuna Uygundur.

Sipariş Kodu	Ürün Kodu	Ölçüler (mm)					Uç	Fiyat
		D	d	Z	H	kg		
T423	D050 d22 Z04 R390 18	50	22	4	45	0,303		₺1.143
T424	D063 d22 Z05 R390 18	63	22	5	45	0,490	R390-1806	₺1.440
T426	D080 d27 Z06 R390 18	80	27	6	52	1,081	SNDVK	₺1.684
T428	D100 d32 Z07 R390 18	100	32	7	52	1,595		₺2.036
T430	D125 d40 Z08 R390 18	125	40	8	62	3,558		₺2.558
T432	D160 d40 Z10 R390 18	160	40	10	62	4,411		₺3.646
		TC074 M4x10		T15				

90° ADMT 1204

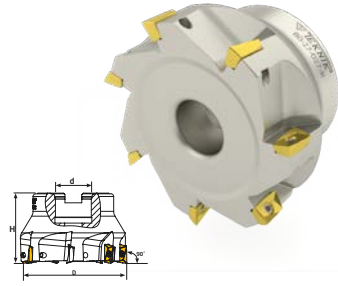

WLTR Ucuna Uygundur.

Sipariş Kodu	Ürün Kodu	Ölçüler (mm)					Uç	Fiyat
		D	d	Z	H	kg		
T214	D040 d16 Z04 ADMT 12	40	16	4	45	0,280		₺1.143
T215	D050 d22 Z05 ADMT 12	50	22	5	45	0,350	ADMT 1204	₺1.440
T217	D063 d22 Z06 ADMT 12	63	22	6	45	0,610	WLTR	₺1.684
T219	D080 d27 Z07 ADMT 12	80	27	7	52	1,176		₺1.934
T220	D100 d32 Z08 ADMT 12	100	32	8	52	1,595		₺2.281
		TC065 M3x7		T8				

90° ADMT 1606

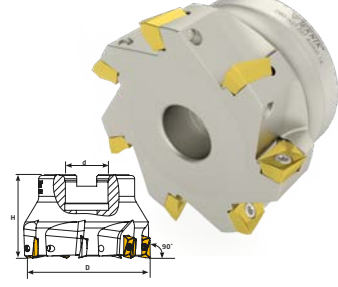

WLTR Ucuna Uygundur.

Sipariş Kodu	Ürün Kodu	Ölçüler (mm)					Uç	Fiyat
		D	d	Z	H	kg		
T351	D040 d16 Z04 ADMT 16	40	16	4	45	0,258		₺1.143
T352	D050 d22 Z05 ADMT 16	50	22	5	45	0,397	ADMT 1606	₺1.440
T354	D063 d22 Z06 ADMT 16	63	22	6	45	0,578	WLTR	₺1.684
T356	D080 d27 Z07 ADMT 16	80	27	7	52	1,254		₺1.934
		TC072 M4x10		T15				

90° BDMT 11T3

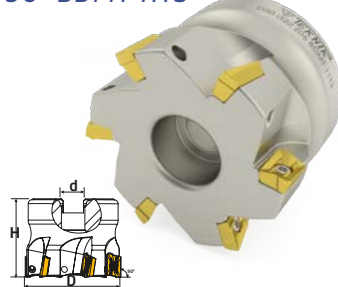

KYCRA Ucuna Uygundur.

Sipariş Kodu	Ürün Kodu	Ölçüler (mm)					Uç	Fiyat
		D	d	Z	H	kg		
T533	D040 d16 Z05 BDMT 11	40	16	5	40	0,224	BDMT 11T3	₺1.440
T534	D050 d22 Z06 BDMT 11	50	22	6	40	0,361	KYCRA	₺1.684
T535	D063 d22 Z07 BDMT 11	63	22	7	40	0,527		₺1.934
		TC060 M2,5x5,5		T8				

90° BDMT 1704

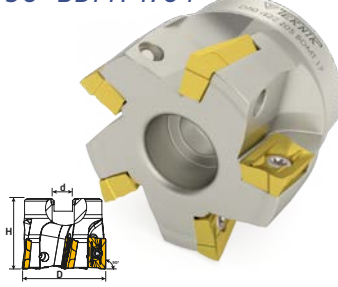

KYCRA Ucuna Uygundur.

Sipariş Kodu	Ürün Kodu	Ölçüler (mm)					Uç	Fiyat
		D	d	Z	H	kg		
T537	D040 d16 Z04 BDMT 17	40	16	4	40	0,190		₺1.143
T538	D050 d22 Z05 BDMT 17	50	22	5	40	0,312	BDMT 1704	₺1.440
T539	D063 d22 Z06 BDMT 17	63	22	6	40	0,516	KYCRA	₺1.684
T540	D080 d27 Z07 BDMT 17	80	27	7	50	1,165		₺1.934
		TC074 M4x10		T15				

90° APKT 1705

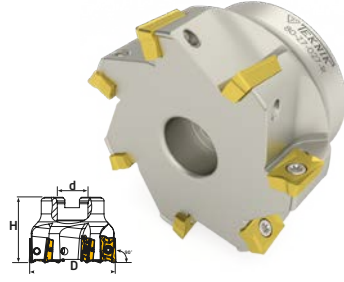

Sipariş Kodu	Ürün Kodu	Ölçüler (mm)					Uç	Fiyat
		D	d	Z	H	kg		
T550	D040 d16 Z04 APKT 17	40	16	4	45	0,239		₺1.143
T552	D050 d22 Z05 APKT 17	50	22	5	45	0,362	APKT 1705	₺1.440
T554	D063 d22 Z06 APKT 17	63	22	6	45	0,520	TGTC	₺1.684
T556	D080 d27 Z07 APKT 17	80	27	7	50	1,047		₺1.934
T558	D100 d32 Z08 APKT 17	100	32	8	52	1,620		₺2.281
		TC074 M4x10		T15				

TGTC Ucuna Uygundur.

90° ADKT 1505

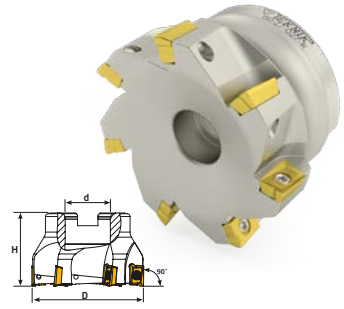

Sipariş Kodu	Ürün Kodu	Ölçüler (mm)					Uç	Fiyat
		D	d	Z	H	kg		
T200	D040 d16 Z04 ADKT 15	40	16	4	45	0,270		₺1.143
T202	D050 d22 Z05 ADKT 15	50	22	5	45	0,394	ADKT 1505	₺1.440
T204	D063 d22 Z06 ADKT 15	63	22	6	45	0,565	ISCR	₺1.684
T206	D080 d27 Z07 ADKT 15	80	27	7	52	1,152		₺1.934
T207	D100 d32 Z08 ADKT 15	100	32	8	52	1,546		₺2.281
T208	D125 d40 Z09 ADKT 15	125	40	9	62	0,272		₺2.876
		TC074 M4x10		T15				

ISCR Ucuna Uygundur.

90° BOMT 1304

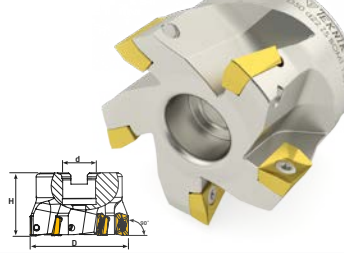

Sipariş Kodu	Ürün Kodu	Ölçüler (mm)					Uç	Fiyat
		D	d	Z	H	kg		
T965	D040 d16 Z04 BOMT 13	40	16	4	40	0,272	BOMT 1304	₺1.143
T966	D050 d22 Z05 BOMT 13	50	22	5	40	0,369	INGRSLL	₺1.440
T967	D063 d22 Z06 BOMT 13	63	22	6	40	0,613		₺1.684
		TC069 M3,5x8,5		T10				

INGRSLL Ucuna Uygundur.

APKT 16 Havşa

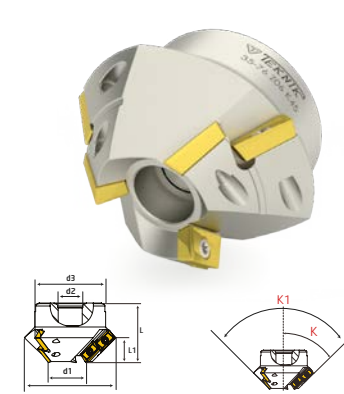

Sipariş Kodu	Ürün Kodu	Ölçüler (mm)										Uç	Fiyat
		K	K1	d1	D	Z	d2	d3	L	L1	kg		
T457	35-50,5 Z06 K15° APKT 16	15°	30°	35	50,5	6	22	45	60	30	0,415		₺2.231
T454	35-65 Z06 K30° APKT 16	30°	60°	35	65	6	27	48	50	26,3	0,610	APKT 1604	₺2.231
T456	35-76 Z06 K45° APKT 16	45°	90°	35	76	6	27	60	50	21,5	0,734	KRLY	₺2.231
T455	35-86 Z06 K60° APKT 16	60°	120°	35	86	6	27	60	50	15	0,892		₺2.231
T458	35-94 Z06 K75° APKT 16	75°	150°	35	94	6	27	60	50	8,5	1,256		₺2.231
		TC074 M4x10		T15									

KRLY Ucuna Uygundur.

F 75° APKT 1604 - APXT 1003

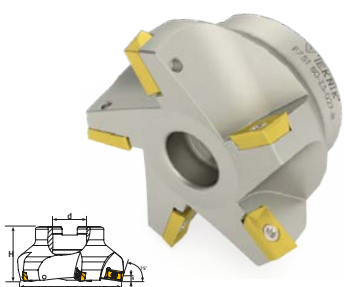

Sipariş Kodu	Ürün Kodu	Ölçüler (mm)					Uç	Fiyat	
		D	d	Z	H	kg			
T308	D063 d22 Z04 APKT 16	63	22	4	45	0,510		₺1.268	
T310	D080 d27 Z05 APKT 16	80	27	5	52	1,120	APKT 1604	₺1.586	
T312	D100 d32 Z06 APKT 16	100	32	6	52	1,587	KRLY	₺1.836	
T313	D125 d40 Z07 APKT 16	125	40	7	62	3,047		₺2.531	
T452	D063 d22 Z06 APXT 10	63	22	6	45	0,630	APXT 1003 KRLY	₺2.036	
		T308-T313 TC074 M4x10		T452 TC074 M4x10		T308-T313 T452 T15 T8			

KRLY Ucuna Uygundur.

90° VCGT 1604

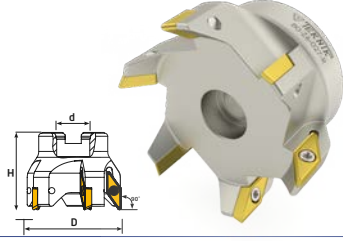

Sipariş Kodu	Ürün Kodu	Ölçüler (mm)					Uç	Fiyat
		D	d	Z	H			
T498	D040 d16 Z03 VCGT 16	40	16	3	52	0,277		₺893
T500	D050 d22 Z04 VCGT 16	50	22	4	52	0,362	VCGT 1604	₺1.143
T502	D063 d22 Z05 VCGT 16	63	22	5	52	0,538	ISO	₺1.440
T504	D080 d27 Z06 VCGT 16	80	27	6	52	0,848		₺1.684
			TC074 M4x10			T15		

F 75° ADKT 1505

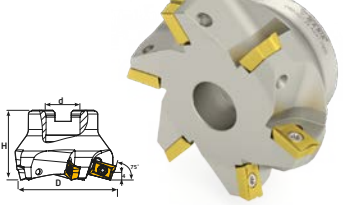

Sipariş Kodu	Ürün Kodu	Ölçüler (mm)					Uç	Fiyat
		D	d	Z	H			
T530	D063 d22 Z05 ADKT 15	63	22	5	45	0,580	ADKT 1505	₺1.440
T532	D080 d27 Z06 ADKT 15	80	27	6	50	1,090	ISCR	₺1.684
			TC074 M4x10			T15		

ISCR Ucuna Uygundur.

Altlıklı - With Shim - Mit U-Platte

TPKN 1603-2204

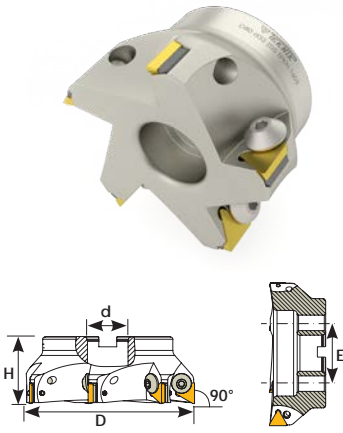

Sipariş Kodu	Ürün Kodu	Ölçüler (mm)						Uç	Fiyat
		D	d	Z	H	E			
T100	D080 d32 Z05 TPKN 16 A	80	32	5	52	--	0,961	TPKN 1603	₺2.081
T102	D100 d32 Z06 TPKN 16 A	100	32	6	52	--	1,518	ISO	₺2.405
T104	D080 d32 Z04 TPKN 22 A	80	32	4	52	--	0,810		₺2.231
T106	D100 d32 Z05 TPKN 22 A	100	32	5	52	--	1,444	TPKN 2204	₺2.580
T108	D125 d40 Z06 TPKN 22 A	125	40	6	62	--	3,164	ISO	₺3.271
T110	D160 d40 Z07 TPKN 22 A	160	40	7	62	66,7	4,220		₺4.118
T112	D200 d60 Z08 TPKN 22 A	200	60	8	62	101,6	5,412		₺5.355
T113	D250 d60 Z09 TPKN 22 A	250	60	9	62	101,6	8,166		₺6.050
Kod									
T100-T102		TC052 M6x17	4 Allen	TA010	TC034 M3				
T104-T113		TC054 M8x24	5 Allen	TA012	TC038 M4x10				

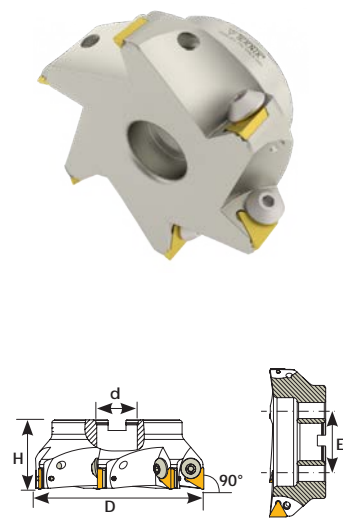

TPKN 1603-2204



Sipariş Kodu	Ürün Kodu	Ölçüler (mm)						Uç	Fiyat
		D	d	Z	H	E			
T114	D042 d16 Z03 TPKN 16	42	16	3	44	--	0,280		₺893
T116	D050 d22 Z03 TPKN 16	50	22	3	44	--	0,340	TPKN 1603	₺920
T118	D063 d22 Z03 TPKN 16	63	22	3	44	--	0,463	ISO	₺1.018
T120	D063 d22 Z04 TPKN 16	63	22	4	44	--	0,481		₺1.188
T122	D080 d32 Z05 TPKN 16	80	32	5	52	--	0,954		₺1.540
T124	D100 d32 Z06 TPKN 16	100	32	6	52	--	1,542		₺1.836
T126	D063 d22 Z03 TPKN 22	63	22	3	50	--	0,532		₺1.018
T128	D080 d32 Z04 TPKN 22	80	32	4	52	--	0,795	TPKN 2204	₺1.586
T130	D100 d32 Z05 TPKN 22	100	32	5	52	--	1,398	ISO	₺1.836
T132	D125 d40 Z06 TPKN 22	125	40	6	62	--	3,153		₺2.430
T134	D160 d40 Z07 TPKN 22	160	40	7	62	66,7	4,150		₺2.828
T136	D200 d60 Z08 TPKN 22	200	60	8	62	101,6	5,458		₺4.064
T138	D250 d60 Z09 TPKN 22	250	60	9	62	101,6	8,235		₺5.453
Kod									
T114-T124		TC052 M6x17	4 Allen						
T126-T138		TC054 M8x24	5 Allen						

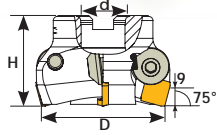

SPKN 1203

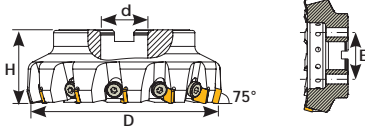

Sipariş Kodu	Ürün Kodu	Ölçüler (mm)				Uç	Fiyat
		ØD	ød	Z	H		
T148	D050 d22 Z03 SPKN 12	50	22	3	45	SPKN 1203	₺919
T150	D063 d22 Z04 SPKN 12	63	22	4	45	ISO	₺1.143
Code		 TC054 M8x24		 5 Allen			

SPKN 1203



Sipariş Kodu	Ürün Kodu	Ölçüler (mm)						Uç	Fiyat
		D	d	Z	H	E	ISO		
T152	D080 d27 Z06 SPKN 12	80	27	6	55	---	1,260		₺1.684
T154	D100 d32 Z08 SPKN 12	100	32	8	55	---	1,698	SPKN 1203	₺2.281
T156	D125 d40 Z10 SPKN 12	125	40	10	62	---	3,400	ISO	₺3.373
T158	D160 d40 Z12 SPKN 12	160	40	12	62	66,7	5,012		₺3.945
T160	D200 d60 Z12 SPKN 12	200	60	12	62	101,6	6,542		₺5.209
T162	D300 d60 Z20 SPKN 12	300	60	20	65	101,6	15,11		₺9.669
Kod		 TC056 Sol M8x24-L		 5 Allen					

THB 01 SET 9-130 mm

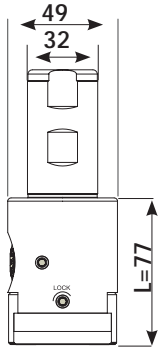
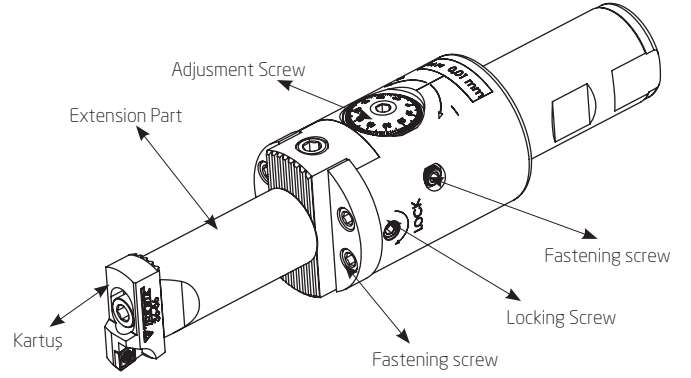
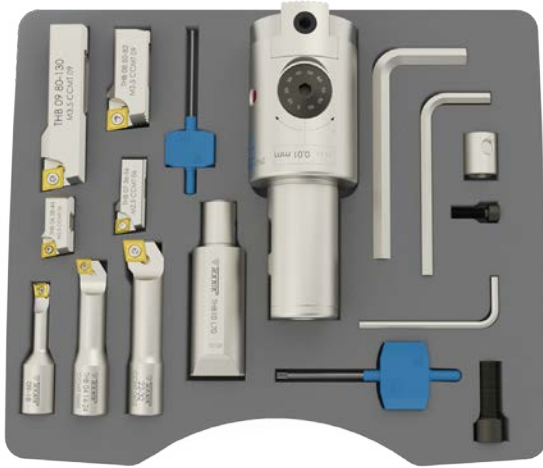

THB 02
GÖVDE
BODY
Fine / Fein

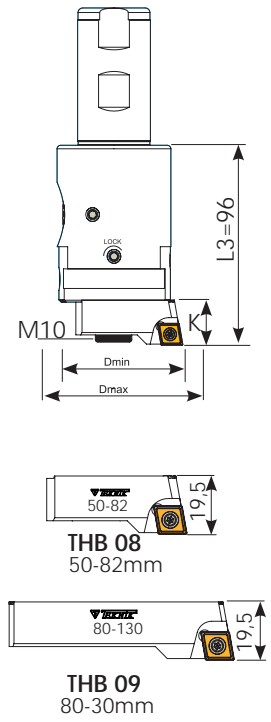
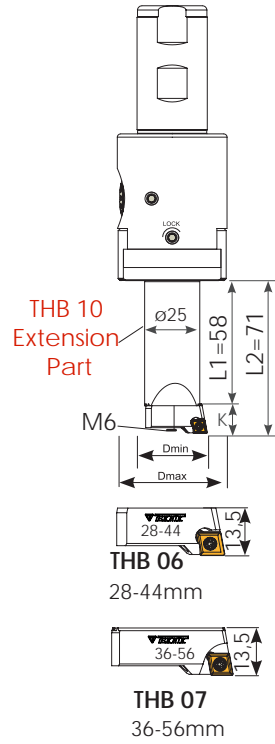
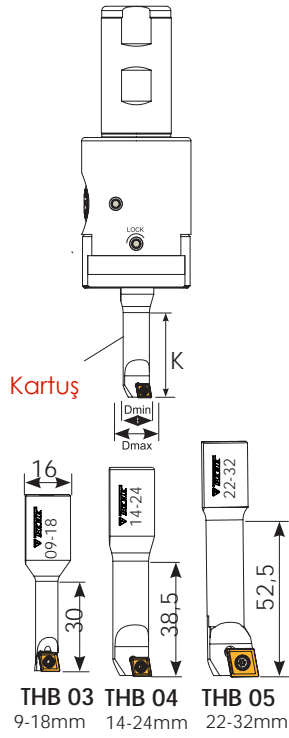
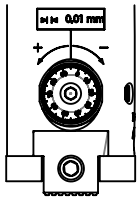

Sipariş Kodu	Ürün Kodu	K	L1	L2	L3	Dmin - Dmax	kg		Fiyat
THB01	Hassas Bara SETİ / SET	9-130	3,100	...	₺15.123
THB02	GÖVDE / BODY	-	...	₺7.585
THB03	09-18 Kartuş	32,5	9-18	-	CCMT 0602	₺614
THB04	14-24 Kartuş	39,6	14-24	-	CCMT 0602	₺795
THB05	22-32 Kartuş	52,5	22-32	-	CCMT 09T3	₺969
THB06	28-44 Kartuş	13,7	...	71	...	28-44	-	CCMT 0602	₺969
THB07	36-56 Kartuş	13,7	...	71	...	36-56	-	CCMT 0602	₺969
THB08	50-82 Kartuş	19,5	95,5	50-82	-	CCMT 09T3	₺1.115
THB09	80-130 Kartuş	19,5	95,5	80-130	-	CCMT 09T3	₺1.188
THB10	ARA UZATMA	...	58	-	...	₺746

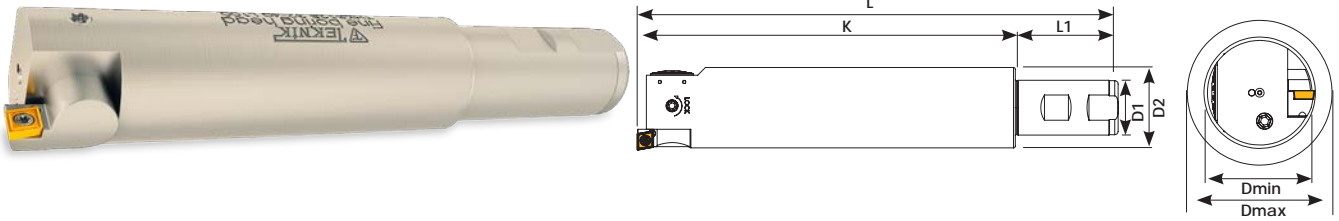

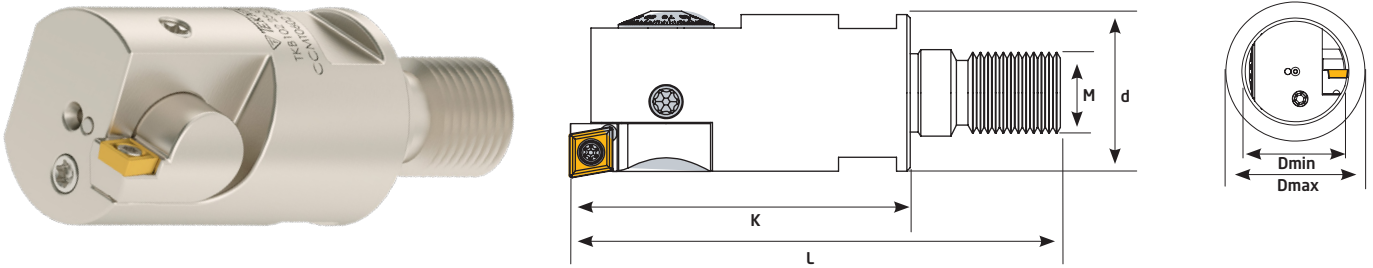

Sipariş Kodu	Ürün Kodu	Ölçüler (mm)								Uç	Hassasiyet → ← (mm)	Fiyat
		Dmin	Dmax	K	D1	L1	D2	L	kg			
THKB120	25-32 K050 CCMT 06	25	32	50	25	56	23	106	0,402	CCMT 0602	0,02	₺6.198
THKB122	25-32 K100 CCMT 06	25	32	100	25	56	23	156	0,570	ISO.		₺6.891
THKB126	32-40 K060 CCMT 06	32	40	60	25	56	29	116	0,510	0,01	₺6.891	
THKB128	32-40 K104 CCMT 06	32	40	104	25	56	29	160	0,760		₺7.038	
THKB132	40-50 K069 CCMT 06	40	50	69	25	56	36	125	0,722	CCMT 0602	₺7.038	
THKB134	40-50 K109 CCMT 06	40	50	109	25	56	36	165	1,085	0,01	₺7.289	
THKB136	40-50 K189 CCMT 06	40	50	189	25	56	36	245	1,723		₺7.634	
THKB138	50-65 K065 CCMT 09	50	65	65	32	60	47	125	1,231	0,01	₺7.191	
THKB140	50-65 K130 CCMT 09	50	65	130	32	60	47	190	2,135		CCMT 09T3	₺7.390
THKB142	50-65 K220 CCMT 09	50	65	220	32	60	47	280	3,383	ISO.	₺7.833	
THKB144	65-80 K085 CCMT 09	65	80	85	32	60	60	145	1,900	0,01	₺7.191	
THKB146	65-80 K130 CCMT 09	65	80	130	32	60	60	190	2,547		₺7.634	
THKB148	65-80 K220 CCMT 09	65	80	220	32	60	60	280	3,895		₺8.083	

25-40 mm Hassas Bara

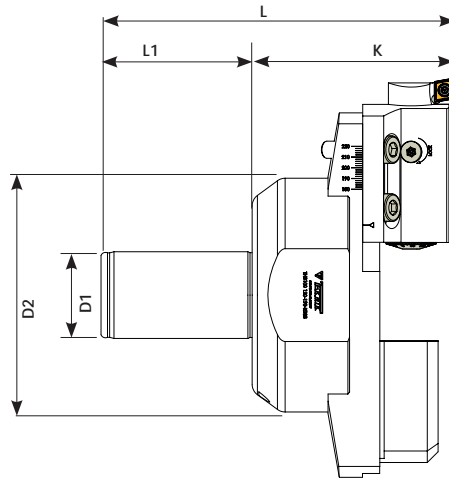
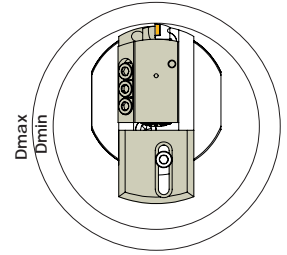

Order Kod	Ürün Kodu	Ölçüler (mm)							Hassasiyet → ← (mm)	Uç	Fiyat
		Dmin	Dmax	M	K	L	d	kg			
THKB102	25-32 K050 M12 CCMT 06	25	32	M12	50	72	23	0,194	0,02	CCMT 0602 ISO.	₺4.908
THKB104	32-40 K050 M16 CCMT 06	32	40	M16	50	74,3	29	0,287	0,01	CCMT 0602 ISO.	₺5.156



Sipariş Kodu	Ürün Kodu	Ölçüler (mm)								Uç	Fiyat
		Dmin	Dmax	K	D1	L1	D2	L			
THB100	120-190 K093 CCMT 09	120	190	93,7	40	70	109	163,7	5,060	CCMT 09T3	₺7.686
THB101	180-240 K093 CCMT 09	180	240	93,7	40	70	109	163,7	5,967	ISO.	₺9.370
THB102	240-300 K093 CCMT 09	240	300	93,7	40	70	109	163,7	7,000		₺11.255

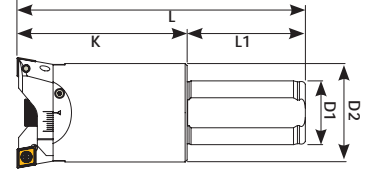
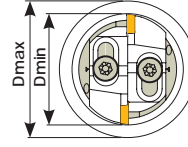

Sipariş Kodu	Ürün Kodu	Ölçüler (mm)								Uç	Fiyat
		Dmin	Dmax	K	D1	L1	D2	L			
TKB088	16-20 K052 WCMX 03	16	20	52	16	48	15,7	100	0,176	WCMX 0302	₺2.775
TKB090	16-20 K102 WCMX 03	16	20	102	16	48	15,7	150	0,237	ISO.	₺2.876
TKB092	16-20 K152 WCMX 03	16	20	152	16	48	15,7	200	0,362		₺3.623
TKB094	19-23 K052 CCMT 06	19	23	52	16	48	17,7	100	0,192		₺2.775
TKB096	19-23 K102 CCMT 06	19	23	102	16	48	17,7	150	0,292	CCMT 0602	₺2.876
TKB098	19-23 K152 CCMT 06	19	23	152	16	48	17,7	200	0,401	ISO.	₺3.623
TKB100	23-28 K050 CCMT 06	23	28	50	20	50	21,2	100	0,298		₺2.775
TKB102	23-28 K100 CCMT 06	23	28	100	20	50	21,2	150	0,347		₺2.876
TKB104	23-28 K185 CCMT 06	23	28	185	20	50	21,2	235	0,682		₺3.623
TKB106	28-38 K055 CCMT 09	28	38	55	20	50	25,7	105	0,378		₺2.828
TKB108	28-38 K105 CCMT 09	28	38	105	20	50	25,7	155	0,376		₺2.951
TKB110	28-38 K174 CCMT 09	28	38	174	25	56	25,7	230	0,267		₺3.720
TKB111	28-38 K274 CCMT 09	28	38	274	25	56	25,7	330	1,342		₺3.819
TKB112	37-48 K064 CCMT 09	37	48	64	25	56	32	120	0,661		₺2.926
TKB114	37-48 K114 CCMT 09	37	48	114	25	56	33	170	0,991	CCMT 0903	₺3.349
TKB116	37-48 K204 CCMT 09	37	48	204	25	56	33	260	1,597	ISO.	₺3.918
TKB118	45-56 K070 CCMT 09	45	56	70	32	60	39,5	130	1,035		₺2.951
TKB120	45-56 K120 CCMT 09	45	56	120	32	60	40	180	1,528		₺3.349
TKB122	45-56 K200 CCMT 09	45	56	200	32	60	40	260	2,385		₺4.118
TKB124	55-75 K085 CCMT 09	55	75	85	32	60	50	145	1,638		₺3.349
TKB126	55-75 K135 CCMT 09	55	75	135	32	60	50	195	2,422		₺3.446
TKB128	55-75 K220 CCMT 09	55	75	220	32	60	50	280	3,745		₺4.218
TKB130	70-90 K085 CCMT 09	70	90	85	32	60	64	145	2,100		₺3.349
TKB132	70-90 K135 CCMT 09	70	90	135	32	60	64	195	2,942		₺3.646
TKB134	70-90 K220 CCMT 09	70	90	220	40	70	64	290	4,915		₺4.218
TKB136	90-130 K115 CCMT 09	90	130	115	32	60	74	175	3,130		₺3.866
TKB138	90-130 K165 CCMT 09	90	130	165	32	60	74	225	4,138		₺4.339

Kartuş

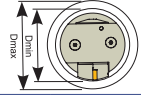
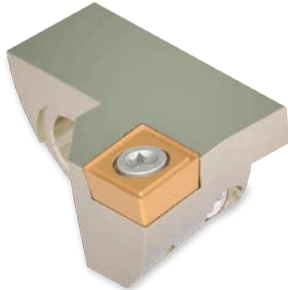

Sipariş Kodu	Dmin-Dmax	Uç	Fiyat
KR096	16-20	WCMX 0302	₺1.018
KR098	19-23	CCMT 0602	₺1.018
KR100	23-28	CCMT 0602	₺1.018
KR102	28-38	CCMT 09T3	₺1.090
KR104	37-48	CCMT 09T3	₺1.143
KR106	45-56	CCMT 09T3	₺1.188
KR108	55-75	CCMT 09T3	₺1.241
KR110	70-90	CCMT 09T3	₺1.268
KR112	90-130	CCMT 09T3	₺1.341
KR115	55-75	CCMT 1204	₺1.218
KR116	70-90	CCMT 1204	₺1.268
KR117	90-130	CCMT 1204	₺1.341

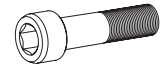

Sipariş Kodu	Sabitleme Cıvatası	Fiyat
TC102	M4x16	₺38
TC102	M4x16	₺38
TC104	M5x25	₺38
TC104	M5x25	₺38
TC106	M6x30	₺38
TC108	M8x25	₺38
TC108	M8x25	₺38
TC108	M8x25	₺38
TC108	M8x25	₺38
TC108	M8x25	₺38
TC108	M8x25	₺38
TC108	M8x25	₺38
TC108	M8x25	₺38

16-38 mm Kaba Bara

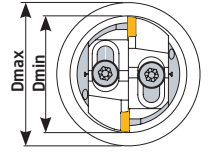
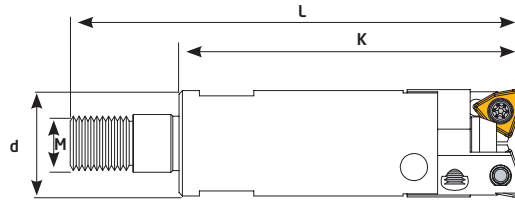

Sipariş Kodu	Ürün Kodu	Ölçüler (mm)							Uç	Fiyat
		Dmin	Dmax	M	K	L	d	kg		
TKB170	16-20 K050 M08 WCMX 03	16	20	M08	50	66	15,5	0,078	WCMX 0302 ISO.	₺2.629
TKB172	19-23 K050 M10 CCMT 06	19	23	M10	50	70	17,5	0,095	CCMT 0602 ISO.	₺2.629
TKB174	23-28 K050 M12 CCMT 06	23	28	M12	50	72	21,2	0,145	CCMT 0602 ISO.	₺2.629
TKB176	28-38 K050 M16 CCMT 09	28	38	M16	50	74,5	25,7	0,213	CCMT 09T3 ISO.	₺2.729

120-350 mm Kaba Bara

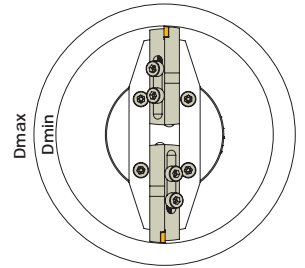
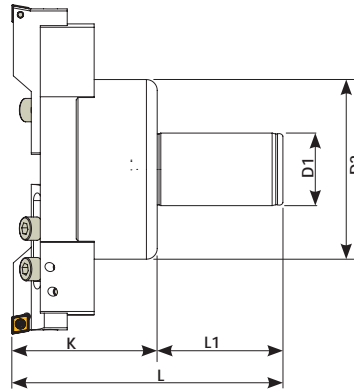

Sipariş Kodu	Ürün Kodu	Ölçüler (mm)								Uç	Fiyat
		Dmin	Dmax	K	D1	L1	D2	L	kg		
TKB148	120-170 K069 CCMT 12	120	170	69	40	70	115,5	139	3,281	CCMT 1204	₺6.396
TKB150	170-250 K084 CCMT 12	170	250	84	40	70	99,5	154	5,011	ISO.	₺9.171
TKB152	240-350 K084 CCMT 12	240	350	84	40	70	149,5	154	8,294		₺10.909

Kartuş

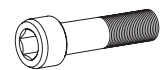
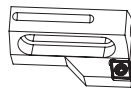
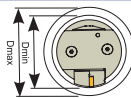

Sipariş Kodu	Dmin-Dmax	Uç	Fiyat	Sipariş Kodu	Sıkma Cıvatası	Fiyat
KR119	120-170	CC MT 1204	₺1.884	TC109	M8x25	₺38
KR120	170-250	CC MT 1204	₺1.963	TC109	M8x25	₺38
KR124	240-350	CC MT 1204	₺2.231	TC109	M8x25	₺38

APKT 1604

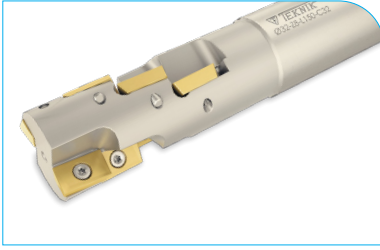

Sipariş Kodu	Ürün Kodu	Ölçüler (mm)						Uç	Fiyat
		D	Z	K	d	L	kg		
HF20	D32 Z06 K43 APKT 16	32	6	43	32	125	0,658		₺4.218
HF22	D40 Z09 K43 APKT 16	40	9	43	32	125	0,821	APKT 1604	₺4.686
HF24	D32 Z08 K58 APKT 16	32	8	58	32	150	0,771	KRLY	₺4.166
HF26	D40 Z12 K58 APKT 16	40	12	58	32	150	0,950		₺6.246
HF30	D32 Z08 K58 APKT 16	32	8	58	32	200	1,120		₺4.166
HF32	D40 Z12 K58 APKT 16	40	12	58	32	200	1,280		₺6.246

 TC074 M4x10

 T15



KRLY ucuna uygundur.

APXT 1003

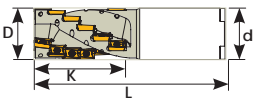
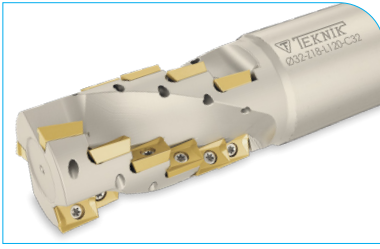

Sipariş Kodu	Ürün Kodu	Ölçüler (mm)						Uç	Fiyat
		D	Z	K	d	L	kg		
HF06	D20 Z06 K28 APXT 10	20	6	28	20	120	0,265		₺3.271
HF07	D25 Z08 K37 APXT 10	25	8	37	25	120	0,404		₺4.166
HF08	D32 Z15 K46 APXT 10	32	15	46	32	120	0,627		₺5.703
HF09	D40 Z18 K55 APXT 10	40	18	55	32	125	0,873		₺6.694
HF10	D20 Z06 K28 APXT 10	20	6	28	20	150	0,326	APXT 1003	₺3.271
HF11	D25 Z08 K37 APXT 10	25	8	37	25	150	0,515	KRLY	₺4.166
HF12	D32 Z15 K46 APXT 10	32	15	46	32	150	1,120		₺5.703
HF13	D40 Z18 K55 APXT 10	40	18	55	32	150	1,100		₺6.694
HF15	D20 Z06 K28 APXT 10	20	6	28	20	200	0,481		₺3.271
HF16	D25 Z08 K37 APXT 10	25	8	37	25	200	0,727		₺4.166
HF17	D32 Z15 K46 APXT 10	32	15	46	32	200	1,144		₺5.703
HF18	D40 Z18 K55 APXT 10	40	18	55	32	200	1,621		₺6.694

 TC060 M2,5x5,5

 T8



KRLY ucuna uygundur.

APKT 1604

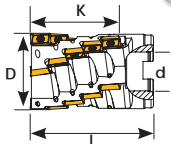

Sipariş Kodu	Ürün Kodu	Ölçüler (mm)						Uç	Fiyat
		D	Z	K	d	L	kg		
HF52	D63 Z20 K75 APKT 16	63	20	75	32	100	1,455	APKT 1604	₺7.931
HF53	D80 Z25 K75 APKT 16	80	25	75	32	100	2,645	KRLY	₺9.669
HF54	D100 Z30 K75 APKT 16	100	30	75	40	100	4,329		₺11.896

 TC074 M4x10

 T15



KRLY ucuna uygundur.

SCMT 09T3-1204

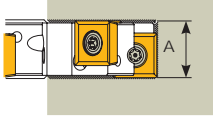
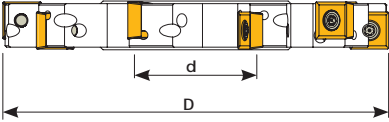

Sipariş Kodu	Ürün Kodu	Ölçüler (mm)					Uç	Fiyat
		D	A	Z	d	kg		
DF086	D080 A10 Z08 SCMT 09	80	10	8	27	0,229		₺2.455
DF092	D100 A10 Z08 SCMT 09	100	10	8	32	0,408		₺2.629
DF100	D125 A10 Z10 SCMT 09	125	10	10	40	0,612		₺3.593
DF108	D160 A10 Z12 SCMT 09	160	10	12	40	1,280		₺4.463
DF116	D200 A10 Z14 SCMT 09	200	10	14	40	1,738		₺5.405
DF088	D080 A12 Z08 SCMT 09	80	12	8	27	0,445	SCMT 09T3	₺2.455
DF094	D100 A12 Z08 SCMT 09	100	12	8	32	0,477	ISO.	₺2.629
DF102	D125 A12 Z10 SCMT 09	125	12	10	40	0,748		₺3.593
DF110	D160 A12 Z12 SCMT 09	160	12	12	40	1,313		₺4.463
DF118	D200 A12 Z14 SCMT 09	200	12	14	40	2,140		₺5.405
DF090	D080 A16 Z08 SCMT 12	80	16	8	27	0,564		₺2.455
DF096	D100 A16 Z08 SCMT 12	100	16	8	32	0,353		₺2.629
DF104	D125 A16 Z10 SCMT 12	125	16	10	40	0,927	SCMT 1204	₺3.593
DF112	D160 A16 Z12 SCMT 12	160	16	12	40	1,634	ISO.	₺4.463
DF120	D200 A16 Z14 SCMT 12	200	16	14	40	2,769		₺5.405
DF106	D125 A20 Z10 SCMT 12	125	20	10	40	1,167		₺3.593
DF114	D160 A20 Z12 SCMT 12	160	20	12	40	2,145		₺4.463

Kod		
DF086-DF118	TC074 M4x10	T15
DF090-DF114	TC083 M5x12	T20

CCMT 0602-09T3-1204

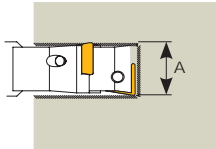
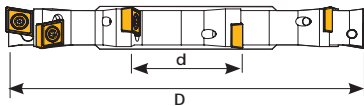
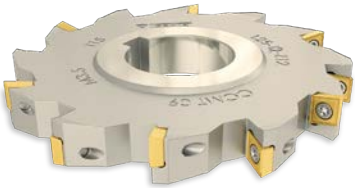

Sipariş Kodu	Ürün Kodu	Ölçüler (mm)					Uç	Fiyat
		D	A	Z	d	kg		
DF150	D080 A08 Z10 CCMT 06	80	8	10	27	0,236		₺2.455
DF160	D100 A08 Z12 CCMT 06	100	8	12	32	0,365		₺2.629
DF170	D125 A08 Z14 CCMT 06	125	8	14	40	0,512		₺3.593
DF182	D160 A08 Z16 CCMT 06	160	8	16	40	0,996	CCMT 0602	₺4.463
DF194	D200 A08 Z18 CCMT 06	200	8	18	40	1,587	ISO.	₺5.405
DF152	D080 A10 Z10 CCMT 06	80	10	10	27	0,289		₺2.455
DF162	D100 A10 Z12 CCMT 06	100	10	12	32	0,453		₺2.629
DF172	D125 A10 Z14 CCMT 06	125	10	14	40	0,703		₺3.593
DF184	D160 A10 Z16 CCMT 06	160	10	16	40	1,228		₺4.463
DF196	D200 A10 Z18 CCMT 06	200	10	18	40	2,035		₺5.405
DF154	D080 A12 Z08 CCMT 09	80	12	8	27	0,470		₺2.463
DF164	D100 A12 Z10 CCMT 09	100	12	10	32	0,472		₺2.629
DF174	D125 A12 Z12 CCMT 09	125	12	12	40	0,750		₺3.593
DF186	D160 A12 Z14 CCMT 09	160	12	14	40	1,360	CCMT 09T3	₺4.463
DF198	D200 A12 Z16 CCMT 09	200	12	16	40	2,400	ISO.	₺5.405
DF156	D080 A14 Z08 CCMT 09	80	14	8	27	0,335		₺2.455
DF166	D100 A14 Z10 CCMT 09	100	14	10	32	0,552		₺2.629
DF176	D125 A14 Z12 CCMT 09	125	14	12	40	0,871		₺3.593
DF188	D160 A14 Z14 CCMT 09	160	14	14	40	1,535		₺4.463
DF200	D200 A14 Z16 CCMT 09	200	14	16	40	2,575		₺5.405
DF158	D080 A16 Z06 CCMT 12	80	16	6	27	0,545		₺2.455
DF168	D100 A16 Z08 CCMT 12	100	16	8	32	0,567		₺2.629
DF178	D125 A16 Z10 CCMT 12	125	16	10	40	1,121	CCMT 1204	₺3.593
DF190	D160 A16 Z12 CCMT 12	160	16	12	40	1,727	ISO.	₺4.463
DF180	D125 A20 Z10 CCMT 12	125	20	10	40	1,430		₺3.593
DF192	D160 A20 Z12 CCMT 12	160	20	12	40	2,650		₺4.463

Kod		
DF150-DF196	TC063 M2,5x7	T8
DF0154-DF200	TC067 M3,5x8,5	T15
DF0158-DF192	TC083 M5x12	T20

CCMT 0602-09T3-1204

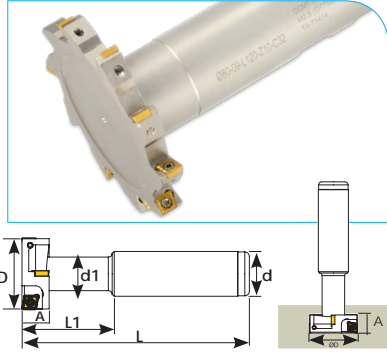

Sipariş Kodu	Ürün Kodu	Ölçüler (mm)								Uç	Fiyat
		D	A	Z	d	d1	L	L1			
TKÇ096	D17 A08 Z02 CCMT 06	17	8	2	16	10	100	28	0,145	CCMT 0602	₺1.290
TKÇ098	D21 A09 Z02 CCMT 06	21	9	2	16	11	100	31,5	0,151	ISO.	₺1.290
TKÇ100	D25 A11 Z04 CCMT 06	25	11	4	20	15	100	32,5	1,232		₺1.388
TKÇ102	D32 A12 Z04 CCMT 06	32	12	4	20	15	100	40	0,300		₺1.468
TKÇ103	D32 A14 Z04 CCMT 09	32	14	4	25	16	100	33	0,434	CCMT 09T3	₺1.468
TKÇ104	D35 A15 Z04 CCMT 09	35	15	4	25	14	100	52	0,447	ISO.	₺1.489
TKÇ106	D40 A17 Z04 CCMT 09	40	17	4	25	20	110	50	0,509		₺1.489
TKÇ108	D50 A20 Z04 CCMT 12	50	20	4	32	26	110	50	0,691	CCMT 1204 ISO	₺1.489
TKÇ120	D63 A09 Z08 CCMT 06	63	9	8	32	19,5	125	37	0,842	CCMT 0602	₺2.926
TKÇ122	D80 A09 Z10 CCMT 06	80	9	10	31,5	32	120	32	1,025	ISO.	₺2.926

Kod		
TKÇ096-TKÇ102	TC060 M2,5x5,5	T8
TKÇ103-TKÇ106	TC067 M3,5x8,5	T15
TKÇ108	TC083 M5x12	T20
TKÇ120-TKÇ122	TC060 M2,5x5,5	T8

SPMG 05-06-07

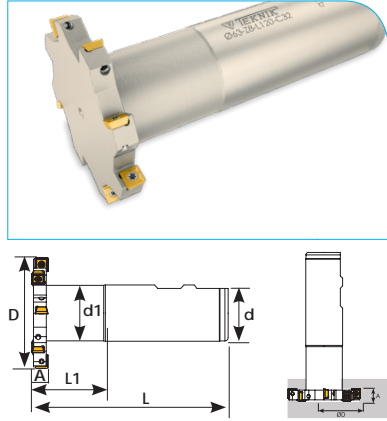

Sipariş Kodu	Ürün Kodu	Ölçüler (mm)								Uç	Fiyat
		D	A	Z	d	d1	L	L1			
TKÇ050	D50 A05 Z07 SPMG 05	50	5	7	32	31,5	120	45	0,830	SPMG 05	₺2.281
TKÇ052	D63 A05 Z08 SPMG 05	63	5	8	32	31,5	120	45	0,861	TGTC.	₺2.455
TKÇ054	D50 A06 Z07 SPMG 06	50	6	7	32	31,5	120	45	0,833		₺2.281
TKÇ056	D63 A06 Z08 SPMG 06	63	6	8	32	31,5	120	45	0,850	SPMG 06	₺2.455
TKÇ058	D80 A06 Z10 SPMG 06	80	6	10	32	31,5	120	45	0,944	TGTC.	₺2.775
TKÇ060	D50 A08 Z06 SPMG 06	50	8	6	32	31,5	120	45	0,839		₺2.281
TKÇ062	D63 A08 Z08 SPMG 06	63	8	8	32	31,5	120	45	0,874		₺2.455
TKÇ064	D80 A08 Z10 SPMG 06	80	8	10	32	31,5	120	45	0,995		₺2.775
TKÇ066	D50 A10 Z06 SPMG 07	50	10	6	32	31,5	120	45	0,496	SPMG 07	₺2.281
TKÇ068	D63 A10 Z08 SPMG 07	63	10	8	32	31,5	120	45	0,868	TGTC.	₺2.455
TKÇ070	D80 A10 Z10 SPMG 07	80	10	10	32	31,5	120	45	0,994		₺2.775

Kod		
TKÇ050-TKÇ052	TC058 M2x4,2	T6
TKÇ054-TKÇ064	TC059 M2,2x5	T7
TKÇ066-TKÇ070	TC063 M2,5x7	T8

TGTC ucuna uygundur.

Round Milling Cutter

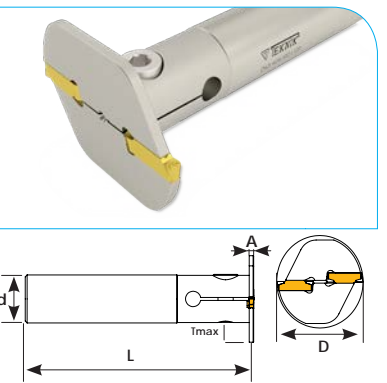

Sipariş Kodu	Ürün Kodu	Ölçüler (mm)						Uç	Fiyat	
		D	A	Z	L	d	Tmax			
TKÇ300	D50 A03 Z02 L-120	50	3	2	120	25	12,75	0,498	MGM 3C	₺1.836
TKÇ301	D63 A03 Z02 L-120	63	3	2	120	25	19,25	0,543	KRLY.	₺1.910
TKÇ302	D80 A03 Z02 L-120	80	3	2	120	32	24,25	0,841		₺2.183
TKÇ303	D50 A04 Z02 L-120	50	4	2	120	25	12,75	0,536	MGM 4C	₺1.836
TKÇ304	D63 A04 Z02 L-120	63	4	2	120	25	19,25	0,556	KRLY.	₺1.910
TKÇ305	D80 A04 Z02 L-120	80	4	2	120	32	24,25	0,860		₺2.183
TKÇ306	D55 A05 Z02 L-120	55	5	2	120	25	15,25	0,513	MGM 5C	₺1.836
TKÇ307	D63 A05 Z02 L-120	63	5	2	120	25	19,25	0,529	KRLY.	₺1.910
TKÇ308	D80 A05 Z02 L-120	80	5	2	120	32	24,25	0,860		₺2.183

	TC136 M8		6 Allen
--	----------	--	---------

KRLY ucuna uygundur.

TCMT 1102 16T3

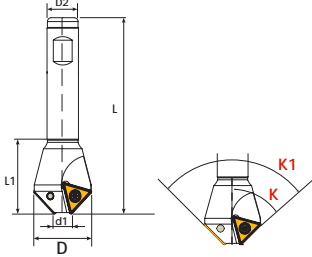

Sipariş Kodu	Ürün Kodu	Ölçüler (mm)										Uç	Fiyat
		K	K1	d1	D	Z	d2	L	L1	(kg)			
S337	06-20 Z01 K30° TCMT 16	30°	60°	6	20	1	16	100	37	0,170	TCMT 16T3	₺695	
S345	10-34 Z02 K30° TCMT 16	30°	60°	10	34	2	20	100	40	0,307	TCMT 16T3	₺795	
S343	24-39 Z02 K30° TCMT 16	30°	60°	24	39	2	20	100	36	0,356	TCMT 16T3	₺795	
S334	04-16 Z01 K45° TCMT 11	45°	90°	4	16	1	16	100	35	0,140	TCMT 1102	₺695	
S341	06-24 Z01 K45° TCMT 16	45°	90°	6	24	1	20	100	30	0,256	TCMT 16T3	₺695	
S336	10-31 Z02 K45° TCMT 16	45°	90°	10	31	2	16	100	35	0,204	TCMT 16T3	₺795	
S338	14-35 Z02 K45° TCMT 16	45°	90°	14	35	2	20	100	35	0,324	TCMT 16T3	₺795	
S340	22-43 Z03 K45° TCMT 16	45°	90°	22	43	3	25	100	37	0,634	TCMT 16T3	₺870	
S342	32-53 Z03 K45° TCMT 16	45°	90°	32	53	3	25	100	37	0,634	TCMT 16T3	₺870	
S335	02-18 Z01 K60° TCMT 11	60°	120°	2	18	1	16	100	35	0,157	TCMT 1102	₺695	
S339	10-31 Z02 K60° TCMT 16	60°	120°	10	31	2	16	100	35	0,213	TCMT 16T3	₺795	
Kod													
S337-S343, S341-S342, S339		TC067 M3,5x8,5		T15									
S334, S335		TC060 M2,5x5,5		T8									

Açılı Havşa

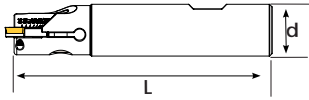

Sipariş Kodu	Ürün Kodu	Ölçüler (mm)						Uç	Fiyat
		D min	D max	d	L	γ°	(kg)		
AH10	D20 R1 L100 TCMT 11	5	27	20	100	10-80	0,241	TCMT 1102 ISO.	₺1.810
AH15	D25 R1 L100 TCMT 16	5	34	25	100	10-80	0,370	TCMT 16T3 ISO.	₺1.861
Kod									
AH10	AH20 TCMT 11	TC063 M2,5x7	M5x12	T8					
AH15	AH21 TCMT 16	TC067 M3,5x8,5	M6x15	T15					

TWX 16R

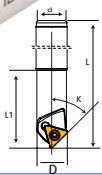
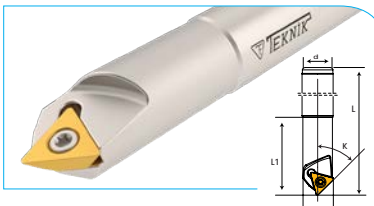

Sipariş Kodu	Ürün Kodu	Ölçüler (mm)							Uç	Fiyat
		K	D	Z	L	d	L1	(kg)		
S352	D21 d20 Z01 L110 TWX 16	45°	21	1	110	20	50	0,260	TWX 16R-KRLY	₺969
		TC072 M4x10		T15						

KRLY ucuna uygundur.

SOMT 11T3

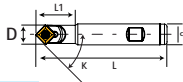

Sipariş Kodu	Ürün Kodu	Ölçüler (mm)						Uç	Fiyat	
		K	D	Z	L	d	L1			(kg)
S769	D16 d16 Z01 L100 SOMT 11	45°	16	1	100	16	32	0,153	SOMT 11T3	₺920
S770	D16 d16 Z01 L150 SOMT 11	45°	16	1	150	16	32	0,238	PLBT	₺1.018
		TC067 M3,5x8,5		T15						

PLBT ucuna uygundur.

Back Facing Milling



Sipariş Kodu	Ürün Kodu	Ölçüler (mm)								Uç	Fiyat
		D	Dmin	K	L	L1	L2	D1			
C100	D18 K40 CCMT 06	18	10	40	47	60	110	20	0,194	CCMT 060204	₺1.388
C102	D20 K45 CCMT 06	20	12	45	52	67	117	20	0,210	ISO.	₺1.388
C104	D26 K60 CCMT 06	26	17	60	67	82	132	20	0,261		₺1.388
C106	D33 K75 CCMT 09	33	21	75	82	102	152	20	0,308	CCMT 09T304 ISO.	₺1.388
Kod											
C100-C104		TC060 M2,5x5				T8					
C106		TC067 M3,5x8,5				T15					

RHKW 1003

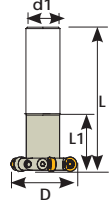

Sipariş Kodu	Ürün Kodu	Ölçüler (mm)						Uç	Fiyat
		D	Z	L	d	L1			
TKÇ200	D40 d20 Z04 L100 RHKW 10	40	4	100	20	40	0,285	RHKW 1003	₺1.614
TKÇ202	D50 d25 Z05 L120 RHKW 10	50	5	120	25	40	0,284	INGRSLL.	₺1.786

INGRSLL ucuna uygundur.

45° SPMG 0904

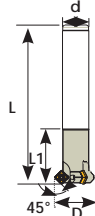
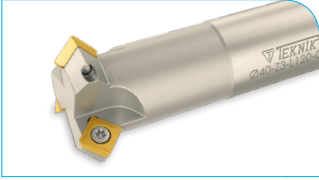

Sipariş Kodu	Ürün Kodu	Ölçüler (mm)						Uç	Fiyat
		D	Z	L	d	L1			
S060	D32 d25 Z02 L150 SPMT 09	32	2	150	25	30	0,589	SPMG 0904	₺1.290
S062	D40 d25 Z03 L150 SPMT 09	40	3	150	25	50	0,562	TGTC.	₺1.388

TGTC ucuna uygundur.

55° DCMT 11T3 - 35° VBMT 1604

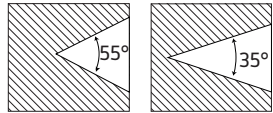
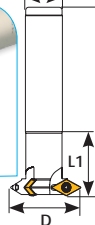
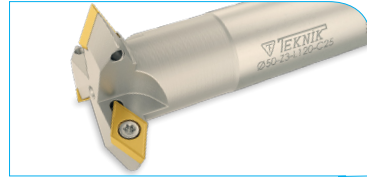

Sipariş Kodu	Ürün Kodu	Ölçüler (mm)						Uç	Fiyat
		D	Z	L	d	L1			
S070	D50 d25 Z03 L120 DCMT 11	50	3	120	25	40	0,584	DCMT 11T3 ISO.	₺1.614
S072	D63 d25 Z04 L120 DCMT 11	63	4	120	25	40	0,536		₺1.786
S073	D75 d25 Z03 L130 VBMT 16	75	3	130	25	40	0,924	VBMT 1604 ISO.	₺1.861
Kod									
S070-S072		TC067 M3.5X9				T15			
S073		TC074 M4x10							

55° DCMT 11T3

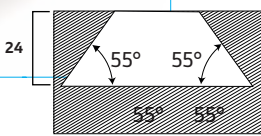
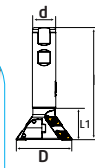
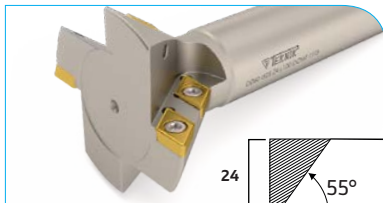

Sipariş Kodu	Ürün Kodu	Ölçüler (mm)						Uç	Fiyat
		D	Z	L	d	L1			
TKÇ251	D60 d25 Z04 L120 DCMT 11	60	4	120	25	35	0,583	DCMT 11T3 ISO.	₺2.183

60° DCMT 11T3

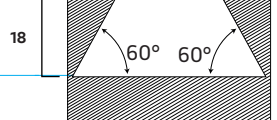
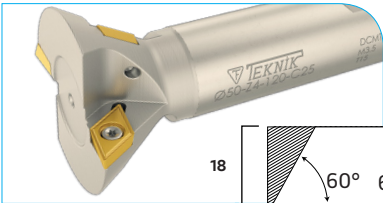

Sipariş Kodu	Ürün Kodu	Ölçüler (mm)						Uç	Fiyat
		D	Z	L	d	L1			
TKÇ250	D50 d25 Z04 L120 DCMT 11	50	4	120	25	30	0,521	DCMT 11T3 ISO.	₺2.183

APXT 1003

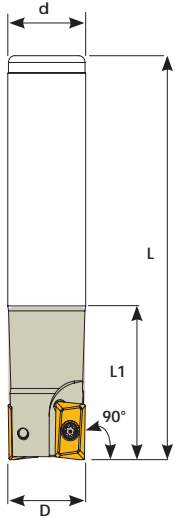

Sipariş Kodu	Ürün Kodu	Ölçüler (mm)							Uç	Fiyat
		D	Z	L	d	L1				
S136	D12 d12 Z01 L100 APXT 10	12	1	100	12	27	0,097		₺695	
S138	D14 d14 Z01 L100 APXT 10	14	1	100	14	30	0,126		₺695	
S140	D16 d16 Z02 L100 APXT 10	16	2	100	16	30	0,156		₺870	
S142	D18 d16 Z02 L100 APXT 10	18	2	100	16	30	0,162		₺870	
S144	D20 d20 Z03 L100 APXT 10	20	3	100	20	30	0,231		₺920	
S146	D22 d20 Z03 L100 APXT 10	22	3	100	20	30	0,243		₺920	
S148	D25 d25 Z03 L100 APXT 10	25	3	100	25	35	0,365		₺920	
S150	D30 d25 Z04 L100 APXT 10	30	4	100	25	40	0,400		₺1.115	
S152	D32 d25 Z04 L100 APXT 10	32	4	100	25	35	0,415		₺1.115	
S154	D35 d25 Z04 L100 APXT 10	35	4	100	25	30	0,452		₺1.115	
S156	D40 d25 Z05 L100 APXT 10	40	5	100	25	30	0,477		₺1.290	
S158	D12 d12 Z01 L120 APXT 10	12	1	120	12	27	0,112		₺746	
S160	D14 d14 Z01 L120 APXT 10	14	1	120	14	30	0,150		₺746	
S162	D16 d16 Z02 L120 APXT 10	16	2	120	16	40	0,185	APXT 1003	₺920	
S164	D18 d16 Z02 L120 APXT 10	18	2	120	16	45	0,190	KRLY.	₺920	
S166	D20 d20 Z03 L120 APXT 10	20	3	120	20	40	0,278		₺993	
S168	D22 d20 Z03 L120 APXT 10	22	3	120	20	40	0,290		₺993	
S169	D25 d25 Z03 L120 APXT 10	25	3	120	25	40	0,452		₺993	
S170	D30 d25 Z04 L120 APXT 10	30	4	120	25	40	0,487		₺1.218	
S171-1	D32 d25 Z04 L120 APXT 10	32	4	120	25	40	0,511		₺1.218	
S171	D35 d25 Z04 L120 APXT 10	35	4	120	25	40	0,532		₺1.218	
S172	D40 d25 Z05 L120 APXT 10	40	5	120	25	40	0,606		₺1.388	
S173	D16 d16 Z02 L150 APXT 10	16	2	150	16	50	0,230		₺1.090	
S174	D18 d16 Z02 L150 APXT 10	18	2	150	16	50	0,246		₺1.090	
S176	D20 d20 Z03 L150 APXT 10	20	3	150	20	60	0,345		₺1.169	
S178	D22 d20 Z03 L150 APXT 10	22	3	150	20	60	0,360		₺1.169	
S180	D25 d25 Z03 L150 APXT 10	25	3	150	25	60	0,563		₺1.169	
S180-1	D30 d25 Z04 L150 APXT 10	30	4	150	25	60	0,610		₺1.341	
S181	D32 d32 Z04 L150 APXT 10	32	4	150	32	45	0,916		₺1.341	
S182	D16 d16 Z02 L200 APXT 10	16	2	200	16	60	0,480		₺1.241	
S184	D18 d16 Z02 L200 APXT 10	18	2	200	16	60	0,350		₺1.241	
S186	D20 d20 Z03 L200 APXT 10	20	3	200	20	70	0,500		₺1.388	
S187	D22 d20 Z03 L200 APXT 10	22	3	200	20	70	0,513		₺1.388	
S188	D25 d25 Z03 L200 APXT 10	25	3	200	25	60	0,771		₺1.388	
S188-1	D30 d25 Z04 L200 APXT 10	30	4	200	25	50	0,845		₺1.638	
S189	D32 d32 Z04 L200 APXT 10	32	4	200	32	60	1,253		₺1.638	
S190	D16 d16 Z02 L250 APXT 10	16	2	250	16	70	0,415		₺1.663	
S192	D20 d20 Z03 L250 APXT 10	20	3	250	20	70	0,623		₺1.884	
S194	D25 d25 Z03 L250 APXT 10	25	3	250	25	70	0,953		₺1.884	

 TC060 M2,5x5,5

 T8



KRLY ucuna uygundur.

APKT 1604

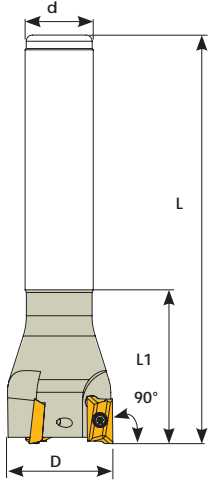



Sipariş Kodu	Ürün Kodu	Ölçüler (mm)							Uç	Fiyat
		D	Z	L	d	L1				
S256	D25 d25 Z02 L120 APKT 16	25	2	120	25	45	0,430		₺870	
S258	D30 d25 Z03 L120 APKT 16	30	3	120	25	45	0,460		₺1.090	
S260	D32 d25 Z03 L120 APKT 16	32	3	120	25	45	0,469		₺1.090	
S262	D35 d25 Z03 L120 APKT 16	35	3	120	25	45	0,498		₺1.090	
S264	D40 d25 Z04 L120 APKT 16	40	4	120	25	45	0,547		₺1.188	
S266	D25 d25 Z02 L150 APKT 16	25	2	150	25	55	0,544		₺1.115	
S268	D30 d25 Z03 L150 APKT 16	30	3	150	25	55	0,575		₺1.241	
S270	D32 d32 Z03 L150 APKT 16	32	3	150	32	55	0,876	APKT 1604	₺1.241	
S272	D35 d32 Z03 L150 APKT 16	35	3	150	32	55	0,915	KRLY.	₺1.241	
S274	D40 d32 Z04 L150 APKT 16	40	4	150	32	55	0,960		₺1.290	
S276	D25 d25 Z02 L200 APKT 16	25	2	200	25	65	0,750		₺1.268	
S278	D30 d25 Z03 L200 APKT 16	30	3	200	25	55	0,783		₺1.388	
S280	D32 d32 Z03 L200 APKT 16	32	3	200	32	55	1,218		₺1.388	
S282	D35 d32 Z03 L200 APKT 16	35	3	200	32	55	1,245		₺1.388	
S283	D40 d32 Z04 L200 APKT 16	40	4	200	32	55	1,296		₺1.540	
S432	D25 d25 Z02 L250 APKT 16	25	2	250	25	70	0,939		₺1.614	
S434	D30 d25 Z03 L250 APKT 16	30	3	250	25	55	1,028		₺1.684	
S436	D32 d32 Z03 L250 APKT 16	32	3	250	32	60	1,520		₺1.684	
S438	D35 d32 Z03 L250 APKT 16	35	3	250	32	65	1,567		₺1.684	
S440	D40 d32 Z04 L250 APKT 16	40	4	250	32	60	1,612		₺1.810	
S442	D25 d25 Z02 L300 APKT 16	25	2	300	25	70	1,127		₺1.786	
S444	D30 d25 Z03 L300 APKT 16	30	3	300	25	60	1,168		₺1.884	
S446	D32 d32 Z03 L300 APKT 16	32	3	300	32	70	1,827		₺1.884	
S448	D35 d32 Z03 L300 APKT 16	35	3	300	32	65	1,879		₺1.884	
S450	D40 d32 Z04 L300 APKT 16	40	4	300	32	70	1,922		₺2.060	
S453	D32 d32 Z03 L350 APKT 16	32	3	350	32	80	2,274		₺2.183	
S454	D35 d32 Z03 L350 APKT 16	35	3	350	32	65	2,332		₺2.183	
S456	D40 d32 Z04 L350 APKT 16	40	4	350	32	55	2,375		₺2.333	



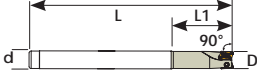
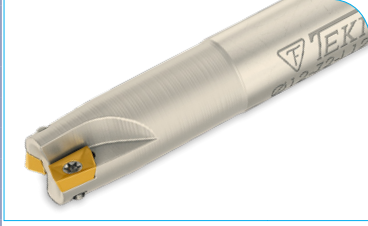

KRLY ucuna uygundur.

APMT 0602





Sipariş Kodu	Ürün Kodu	Ölçüler (mm)						Uç	Fiyat
		D	Z	L	d	L1			
S003	D10 d10 Z02 L080 APMT 06	10	2	80	10	20	0,041		₺1.069
S027	D10 d10 Z02 L100 APMT 06	10	2	100	10	30	0,051		₺1.069
S009	D10 d10 Z02 L120 APMT 06	10	2	120	10	30	0,085		₺1.069
S004	D12 d12 Z03 L080 APMT 06	12	3	80	12	25	0,060	APMT 0602	₺1.316
S028	D12 d12 Z03 L100 APMT 06	12	3	100	12	25	0,075	KRLY.	₺1.316
S011	D12 d12 Z02 L120 APMT 06	12	2	120	12	30	0,120		₺1.069
S005	D16 d16 Z04 L090 APMT 06	16	4	90	16	25	0,120		₺1.511
S029	D16 d16 Z04 L120 APMT 06	16	4	120	16	25	0,164		₺1.563
S006	D20 d20 Z05 L110 APMT 06	20	5	110	20	30	0,240		₺1.731
S030	D20 d20 Z05 L120 APMT 06	20	5	120	20	30	0,263		₺1.750
S007	D25 d25 Z08 L120 APMT 06	25	7	120	25	30	0,411		₺1.950
S008	D32 d32 Z08 L120 APMT 06	32	8	120	32	35	0,686		₺2.170

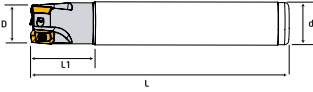

 TC057-1 M1,8x4,1  T6 

KRLY ucuna uygundur.

APMT 0903





Sipariş Kodu	Ürün Kodu	Ölçüler (mm)						Uç	Fiyat
		D	Z	L	d	L1			
S047	D16 d16 Z02 L120 APMT 09	16	2	120	16	30	0,158		₺888
S048	D20 d16 Z03 L120 APMT 09	20	3	120	20	30	0,261	APMT 0903	₺920
S049	D25 d25 Z04 L130 APMT 09	25	4	130	25	30	0,438	KRLY.	₺1.188
S050	D32 d32 Z05 L130 APMT 09	32	5	130	32	30	0,732		₺1.750

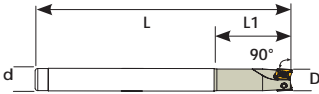

 TC060 M2,5x5,5  T8 

KRLY ucuna uygundur.

APMT 11T3



Sipariş Kodu	Ürün Kodu	Ölçüler (mm)						Uç	Fiyat
		D	Z	L	d	L1			
S222	D10 d10 Z01 L085 APMT 11	10	1	85	10	20	0,059		₺695
S224	D12 d16 Z01 L085 APMT 11	12	1	85	16	25	0,126		₺695
S226	D14 d16 Z01 L090 APMT 11	14	1	90	16	25	0,139		₺695
S228	D16 d16 Z02 L090 APMT 11	16	2	90	16	25	0,138		₺870
S230	D16 d16 Z02 L180 APMT 11	16	2	180	16	30	0,280	APMT 11T3	₺1.218
S232	D20 d20 Z02 L100 APMT 11	20	2	100	20	30	0,243	KRLY.	₺870
S234	D20 d20 Z02 L210 APMT 11	20	2	210	20	30	0,523		₺1.241
S236	D25 d25 Z03 L115 APMT 11	25	3	115	25	35	0,423		₺920
S238	D25 d25 Z03 L180 APMT 11	25	3	180	25	40	0,749		₺1.169
S240	D32 d32 Z04 L125 APMT 11	32	4	125	32	40	0,764		₺1.188
S242	D32 d32 Z04 L180 APMT 11	32	4	180	32	50	1,123		₺1.638

Kod  TC060 M2,5x5,5  T8 



S222-S238 TC061 M2,5x6,5
 S240-S242

KRLY ucuna uygundur.

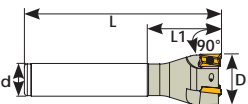
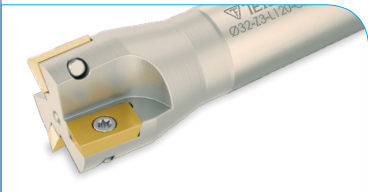
APMT 1604



Sipariş Kodu	Ürün Kodu	Ölçüler (mm)						Uç	Fiyat
		D	Z	L	d	L1			
S244	D25 d25 Z02 L120 APMT 16	25	2	120	25	45	0,430		₺870
S245	D25 d25 Z02 L150 APMT 16	25	2	150	25	55	0,610	APMT 1604	₺1.115
S247	D32 d25 Z03 L120 APMT 16	32	3	120	25	45	0,495	KRLY.	₺1.090
S248	D32 d32 Z03 L150 APMT 16	32	3	150	32	55	0,874		₺1.241
S250	D40 d25 Z04 L120 APMT 16	40	4	120	25	45	0,544		₺1.188
S251	D40 d32 Z04 L150 APMT 16	40	4	150	32	55	1,294		₺1.290

 TC074 M4x10  T15 

KRLY ucuna uygundur.

APKT 1003-1604

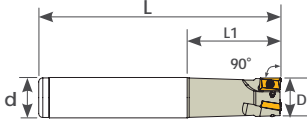

Sipariş Kodu	Ürün Kodu	Ölçüler (mm)						Uç	Fiyat
		D	Z	L	d	L1	kg		
S031	D16 d16 Z02 L100 APKT 10	16	2	100	16	30	0,275		₺893
S032	D20 d20 Z03 L100 APKT 10	20	3	100	20	30	0,342		₺944
S033	D25 d25 Z03 L100 APKT 10	25	3	100	25	35	0,376	APKT 1003	₺944
S034	D32 d25 Z04 L100 APKT 10	32	4	100	25	35	0,768	YG1	₺1.115
S035	D16 d16 Z02 L150 APKT 10	16	2	150	16	50	0,320		₺1.069
S036	D20 d20 Z03 L150 APKT 10	20	3	150	20	60	0,368		₺1.169
S037	D25 d25 Z03 L150 APKT 10	25	3	150	25	60	0,541		₺1.169
S038	D32 d32 Z04 L150 APKT 10	32	4	150	32	45	0,946		₺1.388
S046	D40 d25 Z04 L120 APKT 16	40	4	120	25	45	0,516	APKT 1604 YG1	₺1.241
Kod									
S031-S032,S035-S036		TC060 M2,5x5,5							
S033-S034,S038		TC063 M2,5x7				T8			
S046		TC074 M4x10				T15			

YG1 ucuna uygundur.

R390-11T3 -1704-1806

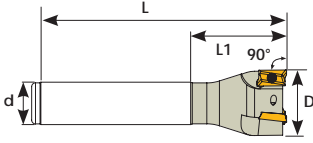

Sipariş Kodu	Ürün Kodu	Ölçüler (mm)						Uç	Fiyat
		D	Z	L	d	L1	kg		
S591	D16 d16 Z02 L120 R390 11	16	2	120	16	40	0,180		₺920
S592	D20 d20 Z03 L120 R390 11	20	3	120	20	40	0,270		₺993
S592-1	D25 d25 Z03 L120 R390 11	25	3	120	25	45	0,446		₺993
S593	D16 d16 Z02 L150 R390 11	16	2	150	16	40	0,229	R390-11T3	₺1.090
S594	D20 d20 Z03 L150 R390 11	20	3	150	20	50	0,348	SNDVK.	₺1.090
S594-1	D21 d20 Z03 L150 R390 11	21	3	150	20	50	0,366		₺1.169
S595	D25 d25 Z03 L150 R390 11	25	3	150	25	50	0,557		₺1.169
S595-1	D26 d25 Z04 L150 R390 11	26	4	150	25	50	0,557		₺1.341
S596	D20 d20 Z03 L200 R390 11	20	3	200	20	50	0,480		₺1.388
S597	D25 d25 Z03 L200 R390 11	25	3	200	25	50	0,762		₺1.388
S598	D25 d25 Z03 L250 R390 11	25	3	250	25	60	0,951		₺1.884
S510	D25 d25 Z02 L120 R390 17	25	2	120	25	45	0,425		₺870
S512	D30 d25 Z03 L120 R390 17	30	3	120	25	45	0,461		₺1.090
S514	D32 d25 Z03 L120 R390 17	32	3	120	25	45	0,459		₺1.090
S518	D40 d32 Z04 L120 R390 17	40	4	120	32	45	0,782		₺1.218
S520	D25 d25 Z02 L150 R390 17	25	2	150	25	55	0,536	R390-1704	₺1.115
S522	D30 d25 Z03 L150 R390 17	30	3	150	25	55	0,582	SNDVK.	₺1.241
S524	D32 d32 Z03 L150 R390 17	32	3	150	32	55	0,854		₺1.241
S528	D40 d32 Z04 L150 R390 17	40	4	150	32	55	0,936		₺1.268
S530	D25 d25 Z02 L200 R390 17	25	2	200	25	60	0,741		₺1.290
S532	D30 d25 Z03 L200 R390 17	30	3	200	25	55	0,773		₺1.365
S534	D32 d32 Z03 L200 R390 17	32	3	200	32	55	0,781		₺1.365
S538	D40 d32 Z04 L200 R390 17	40	4	200	32	55	1,272		₺1.540
S603	D25 d25 Z02 L150 R390 18	25	2	150	25	60	0,530		₺1.115
S600	D25 d25 Z02 L200 R390 18	25	2	200	25	60	0,756	R390-1806	₺1.241
S605	D32 d32 Z03 L150 R390 18	32	3	150	32	60	0,850	SNDVK.	₺1.268
S601	D32 d32 Z03 L200 R390 18	32	3	200	32	60	1,188		₺1.365
Kod									
S591,S593,S594-1,S596		TC060 M2,5x5,5							
S592,S592-1, S594,S595,S595-1		TC063 M2,5x7				T8			
S597,S598									
S510,S538		TC067 M3,5x8,5				T15			
S603,S601		TC074 M4x10				T15			

SNDVK ucuna uygundur.

XOMX 0602- 0903-1204

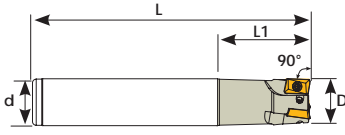

Sipariş Kodu	Ürün Kodu	Ölçüler (mm)						kg	Uç	Fiyat
		D	Z	L	d	L1				
S623	D10 d10 Z02 L120 XOMX 06	10	2	120	10	40	0,086	XOMX 0602	₺1.090	
S625	D12 d12 Z02 L120 XOMX 06	12	2	120	12	30	0,119	SCO.	₺1.090	
S627	D16 d16 Z02 L120 XOMX 09	16	2	120	16	45	0,197		₺944	
S626	D20 d20 Z03 L120 XOMX 09	20	3	120	20	40	0,297	XOMX 0903	₺1.018	
S629	D16 d16 Z02 L150 XOMX 09	16	2	150	16	45	0,228	SCO.	₺1.090	
S628	D20 d20 Z03 L150 XOMX 09	20	3	150	20	55	0,373		₺1.169	
S636	D20 d20 Z03 L200 XOMX 09	20	3	200	20	55	0,507		₺1.388	
S632	D25 d25 Z03 L150 XOMX 09	25	3	150	25	55	0,352		₺1.169	
S638	D20 d20 Z02 L120 XOMX 12	20	2	120	20	45	0,500		₺1.018	
S640	D20 d20 Z02 L150 XOMX 12	20	2	150	20	55	0,439		₺1.169	
S641	D20 d20 Z02 L200 XOMX 12	20	2	200	20	60	0,504	XOMX 1204	₺1.341	
S642	D25 d25 Z03 L120 XOMX 12	25	3	120	25	45	0,443	SCO.	₺1.018	
S643	D25 d25 Z03 L150 XOMX 12	25	3	150	25	55	0,574		₺1.169	
S644	D25 d25 Z03 L200 XOMX 12	25	3	200	25	60	0,779		₺1.388	
S645	D25 d25 Z03 L250 XOMX 12	25	3	250	25	70	0,856		₺1.884	
S647	D32 d32 Z04 L120 XOMX 12	32	4	120	25	45	0,965		₺1.188	
S648	D32 d32 Z04 L150 XOMX 12	32	4	150	32	55	0,937		₺1.341	
S650	D40 d32 Z04 L150 XOMX 12	40	4	150	32	45	1,047		₺1.341	

Kod	TC	T
S623-S625	TC057-1 M1,8x4	T6
S627-S632	TC060 M2,5x5,5	T8
S638-S650	TC069 M3,5x8,5	T10

SCO ucuna uygundur.

APKT 0903

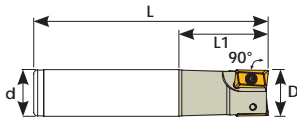
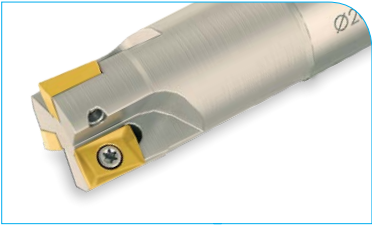

Sipariş Kodu	Ürün Kodu	Ölçüler (mm)						kg	Uç	Fiyat
		D	Z	L	d	L1				
S204	D16 d16 Z02 L120 APKT 09	16	2	120	16	40	0,185		₺920	
S206	D20 d20 Z03 L120 APKT 09	20	3	120	20	45	0,278	APKT 0903	₺993	
S208	D25 d25 Z03 L120 APKT 09	25	3	120	25	45	0,453	WLTR.	₺993	
S210	D16 d16 Z02 L150 APKT 09	16	2	150	16	50	0,237		₺1.090	
S212	D20 d20 Z03 L150 APKT 09	20	3	150	20	45	0,354		₺1.169	
S214	D25 d25 Z03 L150 APKT 09	25	3	150	25	45	0,590		₺1.169	
S216	D16 d16 Z02 L200 APKT 09	16	2	200	16	60	0,340		₺1.241	
S218	D20 d20 Z03 L200 APKT 09	20	3	200	20	60	0,502		₺1.388	
S220	D25 d25 Z03 L200 APKT 09	25	3	200	25	60	0,765		₺1.388	

Kod	TC	T
S204,S210,S216	TC060 M2,5x5,5	T8
S206-S208,S212-S214,S218-S220	TC063 M2,5x7	

WLTR ucuna uygundur.

ADMT 1204

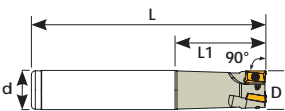
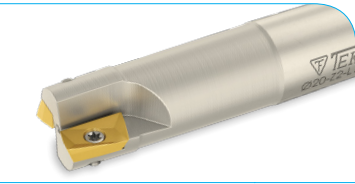

Sipariş Kodu	Ürün Kodu	Ölçüler (mm)						kg	Uç	Fiyat
		D	Z	L	d	L1				
S498	D20 d20 Z02 L120 ADMT 12	20	2	120	20	40	0,275		₺993	
S500	D20 d20 Z02 L150 ADMT 12	20	2	150	20	55	0,348	ADMT 1204	₺1.090	
S501	D20 d20 Z02 L200 ADMT 12	20	2	200	20	60	0,498	WLTR.	₺1.169	
S501-1	D25 d25 Z03 L120 ADMT 12	25	3	120	25	40	0,443		₺1.069	
S502	D25 d25 Z03 L150 ADMT 12	25	3	150	25	60	0,550		₺1.241	
S503	D30 d25 Z04 L150 ADMT 12	30	4	150	25	60	0,558		₺1.290	
S504	D32 d32 Z04 L150 ADMT 12	32	4	150	32	50	0,932		₺1.290	
S506	D40 d32 Z05 L150 ADMT 12	40	5	150	32	50	0,968		₺1.440	

Kod	TC	T
	TC067-1M3x7	T8

WLTR ucuna uygundur.

ADMT 1606



WLTR ucuna uygundur.

Sipariş Kodu	Ürün Kodu	Ölçüler (mm)							Uç	Fiyat
		D	Z	L	d	L1	kg			
S460	D25 d25 Z02 L150 ADMT 16	25	2	150	25	60	0,534		₺1.115	
S461	D25 d25 Z02 L200 ADMT 16	25	2	200	25	60	0,744	ADMT 1606	₺1.290	
S463	D26 d25 Z02 L150 ADMT 16	26	2	150	25	60	0,545	WLTR.	₺1.115	
S464	D26 d25 Z02 L200 ADMT 16	26	2	200	25	60	0,751		₺1.290	
S466	D32 d32 Z03 L150 ADMT 16	32	3	150	32	60	0,784		₺1.241	
S467	D32 d32 Z03 L200 ADMT 16	32	3	200	32	60	1,085		₺1.365	
S469	D40 d32 Z04 L150 ADMT 16	40	4	150	32	60	0,927		₺1.290	
S470	D40 d32 Z04 L200 ADMT 16	40	4	200	32	60	1,310		₺1.540	



AXMT 0602 - APKT 0903

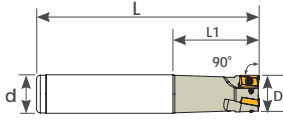
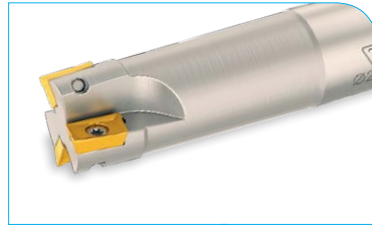

TGTC ucuna uygundur.

Sipariş Kodu	Ürün Kodu	Ölçüler (mm)							Uç	Fiyat
		D	Z	L	d	L1	kg			
S010	D10 d10 Z02 L120 AXMT 06	10	2	120	10	30	0,085	AXMT 0602	₺1.090	
S012	D12 d12 Z02 L120 AXMT 06	12	2	120	12	30	0,119	TGTC.	₺1.090	
S014	D16 d16 Z02 L120 APKT 09	16	2	120	16	40	0,195		₺944	
S016	D20 d20 Z03 L120 APKT 09	20	3	120	20	45	0,296		₺1.018	
S018	D25 d25 Z03 L120 APKT 09	25	3	120	25	45	0,447		₺1.018	
S020	D16 d16 Z02 L150 APKT 09	16	2	150	16	50	0,233	APKT 0903	₺1.090	
S022	D20 d20 Z03 L150 APKT 09	20	3	150	20	60	0,370	TGTC.	₺1.169	
S024	D25 d25 Z03 L150 APKT 09	25	3	150	25	60	0,583		₺1.169	

Kod

S010-S012

S14-S030

TC057-1M1,8x4

TC060 M2,5x5,5

T6

T8



APKT 1705

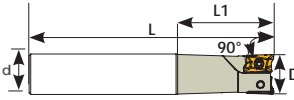

TGTC ucuna uygundur.

Sipariş Kodu	Ürün Kodu	Ölçüler (mm)							Uç	Fiyat
		D	Z	L	d	L1	kg			
S660	D25 d25 Z02 L150 APKT 17	25	2	150	25	60	0,534		₺1.115	
S660-1	D25 d25 Z02 L200 APKT 17	25	2	200	25	60	0,763	APKT 1705	₺1.290	
S662	D32 d32 Z03 L150 APKT 17	32	3	150	32	60	0,850	TGTC.	₺1.241	
S662-1	D32 d32 Z03 L200 APKT 17	32	3	200	32	60	1,236		₺1.365	
S664	D40 d32 Z04 L150 APKT 17	40	4	150	32	60	0,850		₺1.290	



APKT 1003

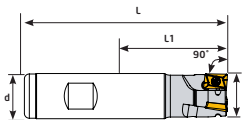

PLBT ucuna uygundur.

Sipariş Kodu	Ürün Kodu	Ölçüler (mm)							Uç	Fiyat
		D	Z	L	d	L1	kg			
S766	D16 d16 Z02 L085 APKT 10	16	2	85	16	26	0,123	APKT 1003	₺1.013	
S767	D20 d20 Z03 L090 APKT 10	20	3	90	20	28	0,209	PLBT	₺1.098	
S768	D25 d20 Z04 L150 APKT 10	25	4	150	20	26	0,388		₺1.549	

Yedek Part

Kod



Sıkma Cıvatası
TC060 M2,5x5,5







Anahtar
T8



BDMT 11T3





Sipariş Kodu	Ürün Kodu	Ölçüler (mm)							Uç	Fiyat
		D	Z	L	d	L1				
S565	D16 d16 Z02 L150 BDMT 11	16	2	150	16	45	0,232		₺1.090	
S566	D18 d16 Z02 L150 BDMT 11	18	2	150	16	44	0,240	BDMT 11T3	₺1.090	
S567	D20 d20 Z03 L150 BDMT 11	20	3	150	20	50	0,351	KYCRA.	₺1.169	
S569	D25 d25 Z03 L150 BDMT 11	25	3	150	25	50	0,563		₺1.169	
S570	D25 d25 Z03 L200 BDMT 11	25	3	200	25	60	0,764		₺1.388	
S572	D32 d32 Z04 L150 BDMT 11	32	4	150	32	50	0,961		₺1.188	
S574	D32 d32 Z04 L200 BDMT 11	32	4	200	32	60	1,294		₺1.638	

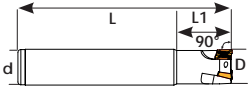

 TC060 M2,5x5,5
  T8
 

KYCRA ucuna uygundur.

BDMT 1704



Sipariş Kodu	Ürün Kodu	Ölçüler (mm)							Uç	Fiyat
		D	Z	L	d	L1				
S578	D25 d25 Z02 L120 BDMT 17	25	2	120	25	35	0,432		₺893	
S579	D25 d25 Z02 L150 BDMT 17	25	2	150	25	50	0,548	BDMT 1704	₺1.115	
S581	D32 d25 Z03 L120 BDMT 17	32	3	120	25	40	0,480	KYCRA.	₺1.090	
S582	D32 d32 Z03 L150 BDMT 17	32	3	150	32	60	0,895		₺1.241	
S584	D40 d32 Z04 L120 BDMT 17	40	4	120	32	40	0,790		₺1.188	
S585	D40 d32 Z04 L150 BDMT 17	40	4	150	32	40	0,985		₺1.268	

Kod
 TC073 M4x8,5
  T15
 



S578,S579 TC073 M4x8,5
 S581-S585 TC074 M4x10

KYCRA ucuna uygundur.

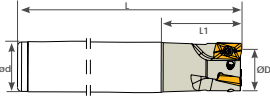
BOMT 1304





Sipariş Kodu	Ürün Kodu	Ölçüler (mm)							Uç	Fiyat
		D	Z	L	d	L1				
S850	D20 d20 Z02 L120 BOMT 13	20	2	120	20	40	0,289		₺969	
S851	D20 d20 Z02 L150 BOMT 13	20	2	150	20	40	0,356	BOMT 1304	₺1.069	
S852	D25 d25 Z03 L120 BOMT 13	25	3	120	25	40	0,451	INGRSL.	₺1.090	
S853	D25 d25 Z03 L150 BOMT 13	25	3	150	25	40	0,556		₺1.241	

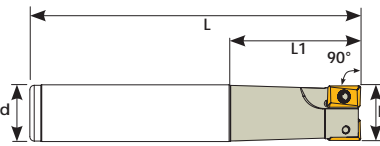

 TC069 M3,5x8,5
  T10
 

INGRSL ucuna uygundur.

ADKT 1505



Sipariş Kodu	Ürün Kodu	Ölçüler (mm)							Uç	Fiyat
		D	Z	L	d	L1				
S304	D25 d25 Z02 L120 ADKT 15	25	2	120	25	45	0,434		₺893	
S306	D30 d25 Z03 L120 ADKT 15	30	3	120	25	45	0,466		₺1.090	
S307	D32 d25 Z03 L120 ADKT 15	32	3	120	25	45	0,477		₺1.090	
S308	D35 d25 Z03 L120 ADKT 15	35	3	120	25	45	0,500		₺1.090	
S310	D40 d32 Z04 L120 ADKT 15	40	4	120	32	45	0,759		₺1.218	
S312	D25 d25 Z02 L150 ADKT 15	25	2	150	25	60	0,550	ADKT 1505	₺1.115	
S314	D30 d25 Z03 L150 ADKT 15	30	3	150	25	50	0,596	ISCR.	₺1.241	
S315	D32 d32 Z03 L150 ADKT 15	32	3	150	32	60	0,887		₺1.241	
S316	D35 d32 Z03 L150 ADKT 15	35	3	150	32	50	0,920		₺1.241	
S318	D25 d25 Z02 L200 ADKT 15	25	2	200	25	55	0,711		₺1.290	
S319	D30 d25 Z03 L200 ADKT 15	30	3	200	25	50	0,783		₺1.365	
S320	D32 d32 Z03 L200 ADKT 15	32	3	200	32	60	1,198		₺1.365	
S321	D35 d32 Z03 L200 ADKT 15	35	3	200	32	50	1,252		₺1.365	
S322	D40 d32 Z04 L200 ADKT 15	40	4	200	32	60	1,272		₺1.540	

 TC074 M4x10
  T15
 

ISCR ucuna uygundur.

ADMX 0702

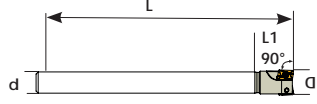

Sipariş Kodu	Ürün Kodu	Ölçüler (mm)						Uç	Fiyat
		D	Z	L	d	L1	$\frac{L1}{D}$		
S751	D10 d10 Z02 L080 ADMX 07	10	2	80	10	16	0,062		₺993
S759	D16 d16 Z03 L160 ADMX 07	16	3	160	16	18	0,205	ADMX 0702	₺1.341
S760	D20 d20 Z04 L125 ADMX 07	20	4	125	20	17	0,293	PRMT.	₺1.440
S761	D20 d20 Z05 L125 ADMX 07	20	5	125	20	17	0,300		₺1.684

TC058 M2x4,2 T6

PRMT ucuna uygundur.

3PKT 1004

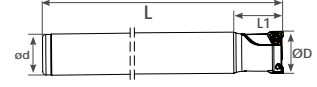

Sipariş Kodu	Ürün Kodu	Ölçüler (mm)						Uç	Fiyat
		D	Z	L	d	L1	$\frac{L1}{D}$		
S485	D21 d20 Z02 L200 3PKT 10	21	2	200	20	30	1,259	3PKT 1004	₺1.341
S486	D26 d25 Z02 L200 3PKT 10	26	2	200	25	30	0,773	TGTC.	₺1.341
S487	D33 d32 Z03 L200 3PKT 10	33	3	200	32	40	0,495		₺1.440

TC093 M2,5x7 T8

TGTC ucuna uygundur.

4NKT 06

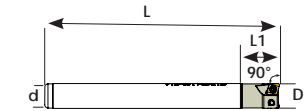

Sipariş Kodu	Ürün Kodu	Ölçüler (mm)						Uç	Fiyat
		D	Z	L	d	L1	$\frac{L1}{D}$		
S471	D16 d16 Z02 L120 4NKT 06	16	2	120	16	25	0,200		₺1.241
S471-1	D16 d16 Z02 L150 4NKT 06	16	2	150	16	25	0,250	4NKT 06	₺1.290
S472	D17 d16 Z02 L150 4NKT 06	17	2	150	16	22	0,241	TGTC.	₺1.290
S473	D20 d20 Z03 L120 4NKT 06	20	3	120	20	25	0,306		₺1.341
S474	D21 d20 Z03 L200 4NKT 06	21	3	200	20	25	0,524		₺1.388
S475	D25 d25 Z04 L120 4NKT 06	25	4	120	25	30	0,474		₺1.414
S475-1	D25 d25 Z03 L200 4NKT 06	25	3	200	25	30	0,806		₺1.489
S476	D26 d25 Z03 L200 4NKT 06	26	3	200	25	30	0,815		₺1.489
S477	D33 d32 Z04 L200 4NKT 06	33	4	200	32	35	1,327		₺1.586
S477-1	D33 d32 Z04 L220 4NKT 06	33	4	220	32	35	1,462		₺1.614
S477-2	D40 d32 Z05 L200 4NKT 06	40	5	200	32	40	1,395		₺1.836

TC064 M3x6,5 T8

TGTC ucuna uygundur.

XNKT 0604

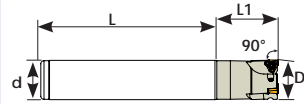

Sipariş Kodu	Ürün Kodu	Ölçüler (mm)						Uç	Fiyat
		D	Z	L	d	L1	$\frac{L1}{D}$		
S834	D20 d20 Z02 L150 XNKT 06	20	2	150	20	40	0,365		₺1.315
S836	D21 d20 Z02 L150 XNKT 06	21	2	150	20	40	0,372	XNKT 0604	₺1.315
S838	D25 d25 Z03 L150 XNKT 06	25	3	150	25	40	0,572	KRLY.	₺1.440
S840	D26 d25 Z03 L150 XNKT 06	26	3	150	25	40	0,572		₺1.440
S841	D32 d32 Z04 L150 XNKT 06	32	4	150	32	40	0,941		₺1.586
S842	D40 d32 Z05 L130 XNKT 06	40	5	130	32	45	0,865		₺1.836

TC065-1 M3x7 T8

KRLY ucuna uygundur.

XNKT 0805

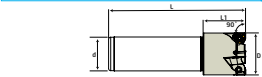

Sipariş Kodu	Ürün Kodu	Ölçüler (mm)						Uç	Fiyat
		D	Z	L	d	L1	$\frac{L1}{D}$		
S843	D32 d32 Z03 L125 XNKT 08	32	3	125	32	37	0,817	XNKT 0805	₺1.463
S844	D40 d32 Z04 L130 XNKT 08	40	4	130	32	40	0,986	KRLY	₺1.573

TC072 M4x10 T15

KRLY ucuna uygundur.

ANKX 1205

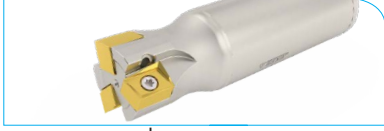

ISCR ucuna uygundur.

Sipariş Kodu	Ürün Kodu	Ölçüler (mm)						Uç	Fiyat
		D	Z	L	d	L1	kg		
S695	D32 d32 Z03 L120 ANKX 12	32	3	120	32	40	0,700	ANKX 1205 ISCR.	₺1.315

TC074 M4x10 T15

ANHX 1004 - 1206

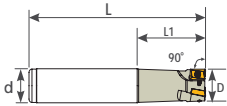

PLBT ucuna uygundur.

Sipariş Kodu	Ürün Kodu	Ölçüler (mm)						Uç	Fiyat
		D	Z	L	d	L1	kg		
S775	D16 d16 Z02 L090 ANHX 10	16	2	90	16	25	0,140		₺1.315
S776	D20 d20 Z02 L100 ANHX 10	20	2	100	20	30	0,247	ANHX 1004	₺1.315
S762	D25 d25 Z03 L115 ANHX 10	25	3	115	25	35	0,432	PLBT	₺1.540
S763	D32 d32 Z03 L125 ANHX 10	32	3	125	32	40	0,783		₺1.540
S782	D16 d16 Z02 L160 ANHX 10	16	2	160	16	25	0,036		₺1.731
S783	D20 d20 Z03 L160 ANHX 10	20	3	160	20	30	0,058		₺1.926
S784	D25 d25 Z03 L180 ANHX 10	25	3	180	25	35	0,099		₺1.926
S785	D32 d32 Z04 L150 ANHX 10	32	4	150	32	40	0,136		₺2.121
S764	D25 d25 Z02 L110 ANHX 12	25	2	110	25	35	0,405	ANHX 1206	₺1.290
S765	D32 d32 Z03 L150 ANHX 12	32	3	150	32	35	0,922	PLBT	₺1.540

Kod TC065 M3x7 T8 T10

S775-S785 TC065 M3x7 T8
S764-S765 TC069 M3,5x8,5 T10

LNGU 15T6



KNNMTL ucuna uygundur.

Sipariş Kodu	Ürün Kodu	Ölçüler (mm)						Uç	Fiyat
		D	Z	L	d	L1	kg		
S950	D25 d25 Z02 L150 LNGU 15	25	2	150	25	45	0,547	LNGU 15T6	₺1.440
S951	D32 d32 Z03 L150 LNGU 15	32	3	150	32	45	0,884	KNNMTL.	₺1.513

TC074 M4x10 T15

LNMX 1006

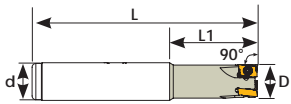

KRLY ucuna uygundur.

Sipariş Kodu	Ürün Kodu	Ölçüler (mm)						Uç	Fiyat
		D	Z	L	d	L1	kg		
LN096	D16 d16 Z01 L090 LNMX 10	16	1	90	16	25	0,140		₺1.098
LN097	D22 d20 Z02 L100 LNMX 10	22	2	100	20	-	0,263	LNMX 1006	₺1.188
LN098	D24 d25 Z03 L100 LNMX 10	24	3	100	25	15	0,389	KRLY.	₺1.241
LN099	D20 d20 Z02 L120 LNMX 10	20	2	120	20	25	0,292		₺1.188
LN100	D20 d20 Z03 L120 LNMX 10	20	3	120	20	25	0,285		₺1.388
LN102	D25 d25 Z03 L120 LNMX 10	25	3	120	25	40	0,453		₺1.388
LN103	D32 d32 Z04 L125 LNMX 10	32	4	125	32	40	0,706		₺1.683
LN104	D40 d32 Z05 L130 LNMX 10	40	5	130	32	42	0,857		₺1.901

TC065 M3x7 T8

LNMX 1510

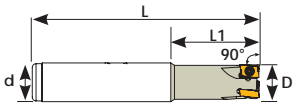
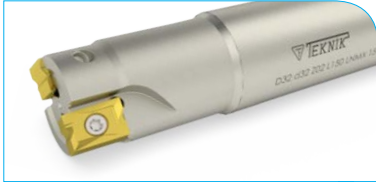

KRLY ucuna uygundur.

Sipariş Kodu	Ürün Kodu	Ölçüler (mm)						Uç	Fiyat
		D	Z	L	d	L1	kg		
S361	D32 d32 Z02 L150 LNMX 15	32	2	150	32	50	0,885	LNMX 1510	₺1.440
S362	D40 d32 Z03 L150 LNMX 15	40	3	150	32	50	0,966	KRLY.	₺1.513

TC076 M4x12,5 T15

WNGX 0403

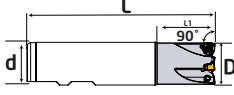

KRLY ucuna uygundur.

Sipariş Kodu	Ürün Kodu	Ölçüler (mm)						Uç	Fiyat
		D	Z	L	d	L1	kg		
S944	D20 d20 Z03 L110 WNGX 04	20	3	110	20	35	0,246	WNGX 0403	₺1.341
S945	D25 d25 Z04 L110 WNGX 04	25	4	110	25	35	0,380	KRLY	₺1.511
S946	D32 d32 Z05 L110 WNGX 04	32	5	110	32	35	0,642		₺1.731



TC060 M2,5x5,5



T8



XNEX 0403

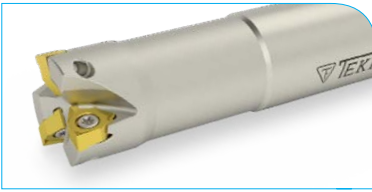

SCO ucuna uygundur.

Sipariş Kodu	Ürün Kodu	Ölçüler (mm)						Uç	Fiyat
		D	Z	L	d	L1	kg		
S195	D20 d20 Z03 L150 XNEX 04	20	3	150	20	40	0,344	XNEX 0403	₺1.414
S196	D21 d20 Z03 L150 XNEX 04	21	3	150	20	40	0,348	SCO	₺1.414
S198	D26 d25 Z04 L150 XNEX 04	26	4	150	25	40	0,535		₺1.585



TC061 M2,5x7



T8



WNGX 0806



KRLY ucuna uygundur.

Sipariş Kodu	Ürün Kodu	Ölçüler (mm)						Uç	Fiyat
		D	Z	L	d	L1	kg		
S949	D40 d32 Z03 L120 WNGX 08	40	3	120	32	40	0,784	WNGX 0806 KRLY	₺1.511



TC083 M5X12



T20



LNMT 0804

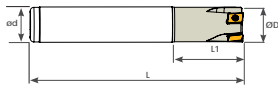

ISCR ucuna uygundur.

Sipariş Kodu	Ürün Kodu	Ölçüler (mm)						Uç	Fiyat
		D	Z	L	d	L1	kg		
S298	D16 d16 Z02 L120 LNMT 08	16	2	120	16	40	0,206		₺1.041
S299	D20 d20 Z03 L120 LNMT 08	20	3	120	20	40	0,313	LNMT 0804	₺1.290
S300	D25 d25 Z04 L120 LNMT 08	25	4	120	25	40	0,477	ISCR.	₺1.290
S300-1	D32 d32 Z05 L120 LNMT 08	32	5	120	32	40	0,775		₺1.489
S301	D16 d16 Z02 L150 LNMT 08	16	2	150	16	40	0,256		₺1.341
S302	D20 d20 Z03 L150 LNMT 08	20	3	150	20	40	0,391		₺1.440
S303	D25 d25 Z04 L150 LNMT 08	25	4	150	25	40	0,601		₺1.489
S303-1	D32 d32 Z05 L150 LNMT 08	32	5	150	32	40	0,978		₺1.638



TC061 M2,5x6,5



T8



WNMU 0403

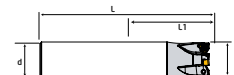

ISCR ucuna uygundur.

Sipariş Kodu	Ürün Kodu	Ölçüler (mm)						Uç	Fiyat
		D	Z	L	d	L1	kg		
S457	D20 d20 Z03 L120 WNMU 04	20	3	120	20	25	0,290	WNMU 0403	₺1.341
S458	D25 d25 Z04 L120 WNMU 04	25	4	120	25	30	0,466	ISCR	₺1.488
S459	D32 d32 Z04 L120 WNMU 04	32	4	120	32	35	0,776		₺1.560



TC060 M2,5x5,5







T8

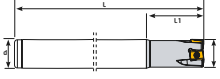

LOEX 0804





Sipariş Kodu	Ürün Kodu	Ölçüler (mm)							Uç	Fiyat
		D	Z	L	d	L1				
S295	D20 d20 Z03 L150 LOEX 08	20	3	150	20	40	0,384	LOEX 0804	₺1.241	
S296	D25 d25 Z04 L150 LOEX 08	25	4	150	25	40	0,604	SCO	₺1.341	





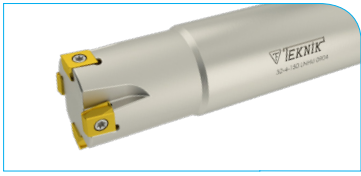

SCO ucuna uygundur.

LNHU 0904



Sipariş Kodu	Ürün Kodu	Ölçüler (mm)							Uç	Fiyat
		D	Z	L	d	L1				
S328	D25 d25 Z03 L150 LNHU 09	25	3	150	25	40	0,599	LNHU 0904	₺1.440	
S329	D32 d32 Z04 L150 LNHU 09	32	4	150	32	40	0,972	WLTR.	₺1.489	





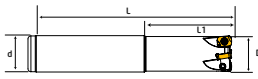
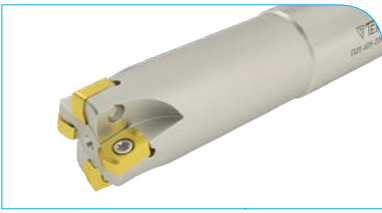

WLTR ucuna uygundur.

LNMX 0603

NEW PRODUCT



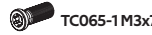

Sipariş Kodu	Ürün Kodu	Ölçüler (mm)							Uç	Fiyat
		D	Z	L	d	L1				
S284	D16 d16 Z02 L110 LNMX 06	16	2	110	16	30	0,172		₺1.316	
S285	D20 d20 Z03 L130 LNMX 06	20	3	130	20	50	0,325	LNMX 0603	₺1.414	
S286	D25 d25 Z04 L140 LNMX 06	25	4	140	25	60	0,552	KRLY	₺1.511	
S287	D32 d32 Z05 L150 LNMX 06	32	5	150	32	70	1,516		₺1.829	





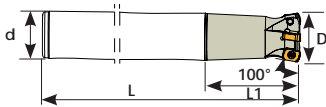

KRLY ucuna uygundur.

BLMP 0603



Sipariş Kodu	Ürün Kodu	Ölçüler (mm)							Uç	Fiyat
		D	Z	L	d	L1				
S479	D16 d16 Z02 L150 BLMP 06	16	2	150	16	40	0,235		₺1.341	
S478	D17 d16 Z02 L150 BLMP 06	17	2	150	16	40	0,244	BLMP 0603	₺1.341	
S481	D20 d20 Z03 L150 BLMP 06	20	3	150	20	40	0,335	TGTC.	₺1.439	
S483	D25 d20 Z04 L150 BLMP 06	25	4	150	20	30	0,280		₺1.511	
S480	D21 d20 Z03 L200 BLMP 06	21	3	200	20	40	0,520		₺1.468	
S482	D26 d25 Z04 L200 BLMP 06	26	4	200	25	40	0,771		₺1.540	









TGTC ucuna uygundur. / Kompatible für TGTC WP

LOGU 0303

NEW PRODUCT



Sipariş Kodu	Ürün Kodu	Ölçüler (mm)							Uç	Fiyat
		D	Z	L	d	L1				
S677	D16 d16 Z02 L150 LOGU 03	16	2	150	16	50	0,219		₺1.341	
S678	D20 d20 Z03 L150 LOGU 03	20	3	150	20	60	0,356	LOGU 0303	₺1.439	
S679	D21 d20 Z03 L150 LOGU 03	21	3	150	20	60	0,365	KYCR	₺1.439	
S680	D25 d25 Z04 L150 LOGU 03	25	4	150	25	60	0,579		₺1.511	

KYCR ucuna uygundur.

Sipariş Kodu	Ürün Kodu	Ölçüler (mm)						Uç	Fiyat
		D	Z	L	d	L1	kg		
S671	D16 d16 Z02 L150 LNMU 03	16	2	150	16	50	0,233		₺1.315
S672	D17 d16 Z02 L150 LNMU 03	17	2	150	16	40	0,241	LNMU 0303	₺1.315
S673	D20 d20 Z03 L150 LNMU 03	20	3	150	20	50	0,381	TNGLY - OKE	₺1.549
S674	D21 d20 Z03 L150 LNMU 03	21	3	150	20	50	0,389		₺1.549
S675	D25 d25 Z04 L150 LNMU 03	25	4	150	25	60	0,589		₺1.658

TC063 M2,5x7 T8

TNGLY - OKE ucuna uygundur.

Sipariş Kodu	Ürün Kodu	Ölçüler (mm)						Uç	Fiyat
		D	Z	L	d	L1	kg		
S105	D16 d16 Z02 L100 ENMX 06	16	2	100	16	30	0,146		₺1.316
S106	D16 d16 Z02 L150 ENMX 06	16	2	150	16	50	0,228	ENMX 0604	₺1.341
S107	D17 d16 Z02 L150 ENMX 06	17	2	150	16	20	0,242	YG1	₺1.341
S108	D20 d20 Z03 L130 ENMX 06	20	3	130	20	50	0,316		₺1.549
S109	D20 d20 Z03 L160 ENMX 06	20	3	160	20	80	0,382		₺1.585
S110	D21 d20 Z03 L150 ENMX 06	21	3	150	20	20	0,391		₺1.585
S111	D25 d25 Z04 L140 ENMX 06	25	4	140	25	60	0,538		₺1.683
S112	D25 d25 Z04 L180 ENMX 06	25	4	180	25	80	0,696		₺1.706
S113	D26 d25 Z04 L150 ENMX 06	26	4	150	25	30	0,612		₺1.683
S114	D32 d32 Z05 L150 ENMX 06	32	5	150	32	70	0,963		₺1.878
S115	D32 d32 Z05 L200 ENMX 06	32	5	200	32	70	0,963		₺1.975

TC063 M2,5x7 T8

YG1 ucuna uygundur.

Sipariş Kodu	Ürün Kodu	Ölçüler (mm)						Uç	Fiyat
		D	Z	L	d	L1	kg		
S934	D25 d25 Z02 L150 ENMX 09	25	2	150	25	70	0,576		₺1.341
S935	D32 d32 Z03 L160 ENMX 09	32	3	160	32	70	1,015	ENMX 0905	₺1.560
S936	D40 d32 Z05 L180 ENMX 09	40	5	180	32	40	1,308	YG1	₺1.780

TC069 M3,5x8,5 T15

YG1 ucuna uygundur.

Sipariş Kodu	Ürün Kodu	Ölçüler (mm)						Uç	Fiyat
		D	Z	L	d	L1	kg		
S395	D25 d25 Z02 L150 SDMT 09	25	2	150	25	60	0,573	SDMT 09T3	₺1.315
S396	D32 d32 Z03 L150 SDMT 09	32	3	150	32	60	0,934	ZCC	₺1.388

TC067 M3,5x8,5 T15

ZCC ucuna uygundur.

WNMX 0603

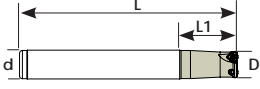

Sipariş Kodu	Ürün Kodu	Ölçüler (mm)						Uç	Fiyat
		D	Z	L	d	L1	kg		
S898	D16 d16 Z02 L150 WNMX 06	16	2	150	16	40	0,241		₺1.315
S899	D20 d20 Z02 L150 WNMX 06	20	2	150	20	40	0,378	WNMX 0603	₺1.315
S903	D17 d16 Z02 L150 WNMX 06	17	2	150	16	40	0,240	KRLY.	₺1.489
S904	D21 d20 Z02 L150 WNMX 06	21	2	150	20	40	0,379		₺1.489
S905	D25 d25 Z03 L150 WNMX 06	25	3	150	25	60	0,578		₺1.540
S906	D26 d25 Z04 L150 WNMX 06	26	4	150	25	60	0,582		₺1.638

TC061 M2,5x6,5
 T8

KRLY ucuna uygundur.

WNMX 09T3

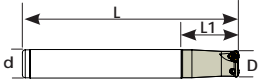

Sipariş Kodu	Ürün Kodu	Ölçüler (mm)						Uç	Fiyat
		D	Z	L	d	L1	kg		
S802	D25 d25 Z02 L150 WNMX 09	25	2	150	25	60	0,563		₺1.315
S803	D26 d25 Z02 L140 WNMX 09	26	2	140	25	60	0,477		₺1.315
S804	D30 d25 Z03 L150 WNMX 09	30	3	150	25	60	0,590	WNMX 09T3	₺1.513
S805	D32 d32 Z03 L150 WNMX 09	32	3	150	32	70	0,841	KRLY.	₺1.513
S806	D33 d32 Z03 L150 WNMX 09	33	3	150	32	70	0,854		₺1.513
S807	D40 d32 Z04 L150 WNMX 09	40	4	150	32	60	0,974		₺1.901

TC065 M3x7
 T8

KRLY ucuna uygundur.

WNMX 1305

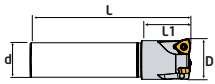

Sipariş Kodu	Ürün Kodu	Ölçüler (mm)						Uç	Fiyat
		D	Z	L	d	L1	kg		
S800	D32 d32 Z02 L120 WNMX 13	32	2	120	32	70	0,933	WNMX 1305	₺1.365
S801	D40 d32 Z03 L150 WNMX 13	40	3	150	32	50	1,069	KRLY	₺1.658

TC074 M4x10

T15



KRLY ucuna uygundur.

SPMG 0502 - 0602-07T3 0904

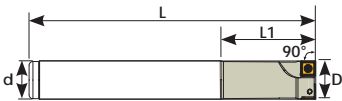
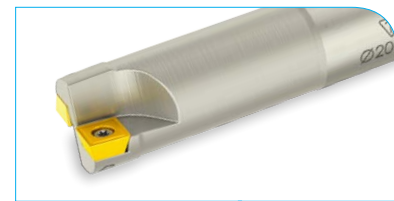

Sipariş Kodu	Ürün Kodu	Ölçüler (mm)						Uç	Fiyat
		D	Z	L	d	L1	kg		
S810	D013 d14 Z02 L120 SPMG 05	13	2	120	14	40	0,147	SPMG 0502	₺920
S812	D13,5 d14 Z02 L120 SPMG 05	13,5	2	120	14	40	0,149	TGTC	₺920
S814	D014 d14 Z02 L120 SPMG 06	14	2	120	14	40	0,148	SPMG 0602	₺920
S818	D015 d16 Z02 L120 SPMG 06	15	2	120	16	40	0,186	TGTC.	₺920
S822	D016 d16 Z02 L120 SPMG 06	16	2	120	16	40	0,194		₺920
S824	D020 d20 Z02 L150 SPMG 07	20	2	150	20	50	0,198	SPMG 07T3	₺1.090
S826	D20,5 d20 Z02 L120 SPMG 07	20,5	2	120	20	50	0,290	TGTC.	₺969
S828	D025 d25 Z02 L150 SPMG 09	25	2	150	25	50	0,567	SPMG 0904	₺1.169
S830	D032 d32 Z03 L150 SPMG 09	32	3	150	32	40	0,908	TGTC	₺1.290

Kod

S810-S812 TC058 M2x4,2

S814-S822 TC059 M2,2x5

S824-S826 TC063 M2,5x7

S828-S830 TC067 M3,5x8,5



TGTC ucuna uygundur. / Kompatible für TGTC WP

VCGT 1604

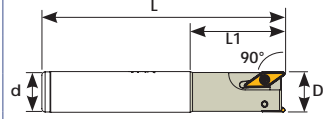

Sipariş Kodu	Ürün Kodu	Ölçüler (mm)							Uç	Fiyat
		D	Z	L	d	L1	kg			
S710	D25 d25 Z02 L150 VCGT 16	25	2	150	25	50	0,518		₺1.169	
S712	D32 d32 Z02 L150 VCGT 16	32	2	150	32	60	0,852	VCGT 1604	₺1.241	
S714	D40 d32 Z03 L150 VCGT 16	40	3	150	32	60	0,951	ISO.	₺1.290	
S718	D25 d25 Z02 L200 VCGT 16	25	2	200	25	60	0,730		₺1.268	
S720	D32 d32 Z02 L200 VCGT 16	32	2	200	32	60	1,225		₺1.315	
S724	D25 d25 Z02 L250 VCGT 16	25	2	250	25	60	0,920		₺1.586	
S726	D32 d32 Z02 L250 VCGT 16	32	2	250	32	60	1,250		₺1.684	

TC074 M4x10 T15

F75° APXT 1003

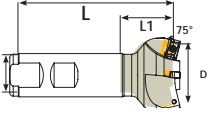

Sipariş Kodu	Ürün Kodu	Ölçüler (mm)							Uç	Fiyat
		D	Z	L	d	L1	kg			
S344	D32 d25 Z03 L100 APXT 10	32	3	100	25	35	0,413		₺1.018	
S346	D40 d25 Z04 L100 APXT 10	40	4	100	25	35	0,494	APXT 1003	₺1.090	
S348	D45 d25 Z04 L100 APXT 10	45	4	100	25	35	0,535	KRLY.	₺1.090	
S350	D50 d25 Z05 L100 APXT 10	50	5	100	25	35	0,583		₺1.290	

TC060 M2,5x5,5 T8

KRLY ucuna uygundur.

Küre Uçlu Freze

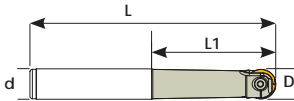

Sipariş Kodu	Ürün Kodu	Ölçüler (mm)					Uç	Fiyat
		D	L	d	L1	kg		
S370	D08 d10 L130 P32-08	8	130	10	36	0,092	P32 08 WLTR.	₺1.143
S372	D10 d12 L130 P32-10	10	130	12	46	0,118	P32 10 WLTR.	₺1.143
S374	D12 d12 L150 P32-12	12	150	12	46	0,142	P32 12 WLTR.	₺1.188
S376	D16 d16 L175 P32-16	16	175	16	46	0,270	P32 16 WLTR.	₺1.241
S378	D20 d20 L200 P32-20	20	200	20	56	0,505	P32 20 WLTR.	₺1.365
S380	D25 d25 L200 P32-25	25	200	25	66	0,745	P32 25 WLTR.	₺1.440
S381	D30 d32 L200 P32-30	30	200	32	66	1,148	P32 30 WLTR.	₺1.513
S382	D32 d32 L200 P32-32	32	200	32	66	1,150	P32 32 WLTR.	₺1.513

Kod	TC	M	T
S370	TC170	M3	T8
S372	TC172	M4	T15
S374	TC174	M5	T20
S376	TC176	M5	T20
S378	TC178	M5	T20
S380	TC181	M6	3 Allen
S381-S382	TC184	M8	4 Allen

WLTR ucuna uygundur.

RDMT 1003-12T3

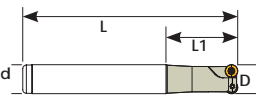

Sipariş Kodu	Ürün Kodu	Ölçüler (mm)							Uç	Fiyat
		D	Z	L	d	L1	kg			
S771	D20 d20 Z02 L160 RDMT 10	20	2	160	20	60	0,359	RDMT 1003	₺1.440	
S772	D20 d25 Z02 L220 RDMT 10	20	2	220	25	120	0,658	PLBT	₺1.440	
S773	D25 d25 Z02 L220 RDMT 12	25	2	220	25	120	0,741	RDMT 12T3	₺1.540	
S774	D25 d32 Z02 L230 RDMT 12	25	2	230	32	130	1,099	PLBT	₺1.540	

Kod	TC	M	T
S771-S772	TC071	M3,5x7	T15
S773-S774	TC067	M3,5x8,5	

PLBT ucuna uygundur.

RDMW 0501

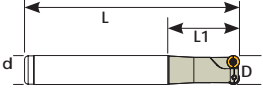
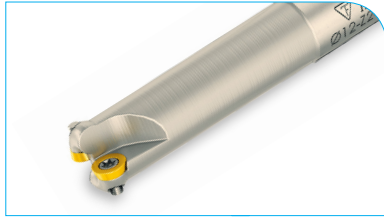

Sipariş Kodu	Ürün Kodu	Ölçüler (mm)						Uç	Fiyat
		D	Z	L	d	L1			
R080	D08 d10 Z01 L080 RDMW 05	8	1	80	10	27	0,053		₺993
R082	D10 d12 Z02 L080 RDMW 05	10	2	80	12	34	0,076	RDMW 0501	₺993
R083	D10 d12 Z02 L100 RDMW 05	10	2	100	12	40	0,085	TGTC.	₺991
R084	D10 d12 Z02 L120 RDMW 05	10	2	120	12	45	0,111		₺993
R086	D12 d12 Z02 L100 RDMW 05	12	2	100	12	40	0,099		₺993
R088	D12 d12 Z02 L120 RDMW 05	12	2	120	12	45	0,118		₺993



TGTC ucuna uygundur. / Kompatible für TGTC WP

RDMW 0702

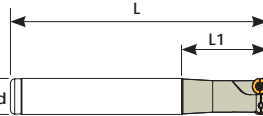

Sipariş Kodu	Ürün Kodu	Ölçüler (mm)						Uç	Fiyat
		D	Z	L	d	L1			
R136	D15 d16 Z02 L120 RDMW 07	15	2	120	16	40	0,187		₺1.041
R138	D16 d16 Z02 L120 RDMW 07	16	2	120	16	40	0,148	RDMW 0702	₺1.041
R142	D20 d20 Z03 L120 RDMW 07	20	3	120	20	45	0,278	TGTC.	₺1.090
R143	D15 d16 Z02 L150 RDMW 07	15	2	150	16	50	0,228		₺1.143
R144	D16 d16 Z02 L150 RDMW 07	16	2	150	16	60	0,230		₺1.143
R148	D20 d20 Z03 L150 RDMW 07	20	3	150	20	60	0,354		₺1.241



TGTC ucuna uygundur. / Kompatible für TGTC WP

RPMW 0803

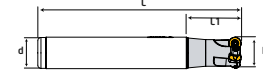

Sipariş Kodu	Ürün Kodu	Ölçüler (mm)						Uç	Fiyat
		D	Z	L	d	L1			
R310	D16 d16 Z02 L130 RPMW 08	16	2	130	16	35	0,198		₺1.146
R311	D18 d16 Z02 L150 RPMW 08	18	2	150	16	35	0,240	RPMW 0803	₺1.146
R312	D20 d20 Z03 L130 RPMW 08	20	3	130	20	35	0,316	KRLY	₺1.341
R313	D25 d25 Z04 L150 RPMW 08	25	4	150	25	35	0,591		₺1.511



KRLY ucuna uygundur.

RPMW 10T3

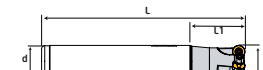
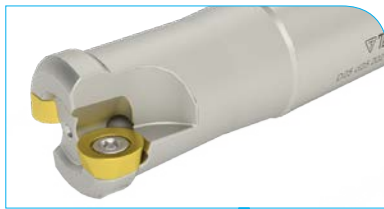

Sipariş Kodu	Ürün Kodu	Ölçüler (mm)						Uç	Fiyat
		D	Z	L	d	L1			
R316	D20 d20 Z02 L120 RPMW 10	20	2	120	20	40	0,282		₺1.118
R317	D25 d25 Z02 L120 RPMW 10	25	2	120	25	40	0,447	RPMW 10T3	₺1.118
R318	D25 d25 Z02 L160 RPMW 10	25	2	160	25	60	0,617	KRLY	₺1.341
R319	D32 d32 Z04 L125 RPMW 10	32	4	125	32	40	0,792		₺1.390
R320	D32 d25 Z04 L200 RPMW 10	32	4	200	25	60	0,891		₺1.634
R321	D40 d32 Z04 L150 RPMW 10	40	4	150	32	35	1,071		₺1.634

Kod



R316

TC071 M3,5x7

T15

R317-R321

TC067 M3,5x8,5

KRLY ucuna uygundur.

RPMW 1204

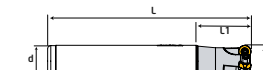

Sipariş Kodu	Ürün Kodu	Ölçüler (mm)						Uç	Fiyat
		D	Z	L	d	L1			
R325	D25 d25 Z02 L160 RPMW 12	25	2	160	25	60	0,607		₺1.390
R326	D32 d32 Z03 L160 RPMW 12	32	3	160	32	60	1,017	RPMW 1204	₺1.585
R327	D40 d32 Z04 L150 RPMW 12	40	4	150	32	35	1,056	KRLY	₺1.634



KRLY ucuna uygundur.

RDMT 1003

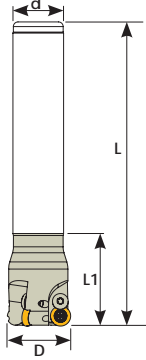

Sipariş Kodu	Ürün Kodu	Ölçüler (mm)						Uç	Fiyat
		D	Z	L	d	L1			
R190	D20 d20 Z02 L120 RDMT 10	20	2	120	20	55	0,265		₺1.115
R192	D25 d25 Z02 L120 RDMT 10	25	2	120	25	50	0,435		₺1.115
R193	D30 d25 Z03 L120 RDMT 10	30	3	120	25	40	0,468		₺1.290
R194	D32 d25 Z03 L120 RDMT 10	32	3	120	25	40	0,484		₺1.290
R196	D35 d25 Z03 L120 RDMT 10	35	3	120	25	45	0,508	RDMT 1003	₺1.290
R198	D40 d25 Z04 L120 RDMT 10	40	4	120	25	45	0,558	ISO.	₺1.365
R200	D20 d20 Z02 L150 RDMT 10	20	2	150	20	60	0,336		₺1.341
R202	D25 d25 Z02 L150 RDMT 10	25	2	150	25	60	0,544		₺1.341
R203	D30 d25 Z03 L150 RDMT 10	30	3	150	25	40	0,586		₺1.414
R204	D32 d32 Z03 L150 RDMT 10	32	3	150	32	45	0,898		₺1.414
R206	D35 d32 Z03 L150 RDMT 10	35	3	150	32	45	0,923		₺1.414
R208	D40 d32 Z04 L150 RDMT 10	40	4	150	32	45	0,967		₺1.513
R210	D20 d20 Z02 L200 RDMT 10	20	2	200	20	80	0,477		₺1.440
R212	D25 d25 Z02 L200 RDMT 10	25	2	200	25	70	0,747		₺1.440
R213	D30 d25 Z03 L200 RDMT 10	30	3	200	25	40	0,789		₺1.513
R214	D32 d32 Z03 L200 RDMT 10	32	3	200	32	45	1,273		₺1.513
R216	D35 d32 Z03 L200 RDMT 10	35	3	200	32	45	1,227		₺1.513
R218	D40 d32 Z04 L200 RDMT 10	40	4	200	32	45	1,281		₺1.614

Kod				
R190	TC071 M3,5x7	TC040 M3,5		
R192-R218	TC067 M3,5x8,5	TC040 M3,5		

RDMT 12T3

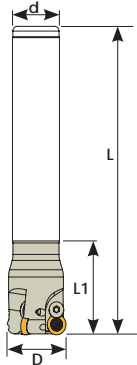
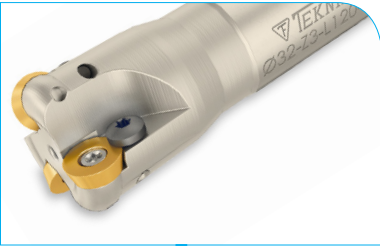

Sipariş Kodu	Ürün Kodu	Ölçüler (mm)						Uç	Fiyat
		D	Z	L	d	L1			
R228	D25 d25 Z02 L120 RDMT 12	25	2	120	25	50	0,422		₺1.115
R229	D30 d25 Z02 L120 RDMT 12	30	2	120	25	40	0,456		₺1.115
R230	D32 d25 Z03 L120 RDMT 12	32	3	120	25	40	0,473		₺1.290
R232	D35 d25 Z03 L120 RDMT 12	35	3	120	25	40	0,485		₺1.290
R234	D40 d25 Z03 L120 RDMT 12	40	3	120	25	40	0,513	RDMT 12T3	₺1.290
R236	D25 d25 Z02 L150 RDMT 12	25	2	150	25	60	0,539	ISO.	₺1.341
R237	D30 d25 Z02 L150 RDMT 12	30	2	150	25	55	0,536		₺1.341
R238	D32 d32 Z03 L150 RDMT 12	32	3	150	32	45	0,876		₺1.414
R240	D35 d32 Z03 L150 RDMT 12	35	3	150	32	45	0,900		₺1.414
R242	D40 d32 Z03 L150 RDMT 12	40	3	150	32	45	0,956		₺1.414
R244	D25 d25 Z02 L200 RDMT 12	25	2	200	25	70	0,740		₺1.440
R245	D30 d25 Z02 L200 RDMT 12	30	2	200	25	55	0,784		₺1.440
R246	D32 d32 Z03 L200 RDMT 12	32	3	200	32	45	1,201		₺1.513
R248	D35 d32 Z03 L200 RDMT 12	35	3	200	32	45	1,226		₺1.513
R250	D40 d32 Z03 L200 RDMT 12	40	3	200	32	45	1,287		₺1.513
R255	D30 d25 Z02 L300 RDMT 12	30	2	300	25	55	1,168		₺1.836
R256	D32 d32 Z03 L300 RDMT 12	32	3	300	32	70	1,829		₺2.036
R258	D35 d32 Z03 L300 RDMT 12	35	3	300	32	45	1,855		₺2.036
R260	D40 d32 Z03 L300 RDMT 12	40	3	300	32	45	1,995		₺2.081

Kod				
	TC067 M3,5x8,5	T15	TC040 M3,5	

TPKN 1103-1603-2204

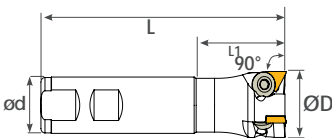
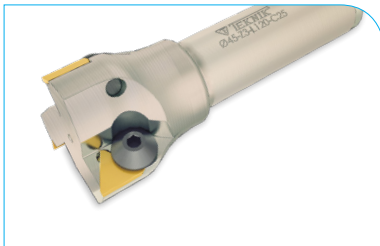

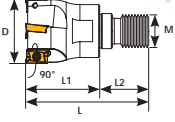

Sipariş Kodu	Ürün Kodu	Ölçüler (mm)						Uç	Fiyat
		D	Z	L	d	L1			
S116	D22 d20 Z02 L120 TPKN 11	22	2	120	20	45	0,301		₺893
S118	D25 d25 Z02 L120 TPKN 11	25	2	120	25	45	0,438	TPKN 1103	₺893
S124	D32 d25 Z03 L120 TPKN 11	32	3	120	25	45	0,480	ISO	₺969
S128	D35 d25 Z02 L120 TPKN 16	35	2	120	25	45	0,507	TPKN 1603	₺993
S130	D40 d25 Z03 L120 TPKN 16	40	3	120	25	45	0,552	ISO	₺1.090
S132	D45 d25 Z03 L120 TPKN 16	45	3	120	25	45	0,606		₺1.143
S134	D50 d32 Z03 L120 TPKN 22	50	3	120	32	55	0,896	TPKN 2204 ISO	₺1.241

Kod			
S116-S124	TC050 M6x14	3 Allen	
S128-S132	TC052 M6x17	4 Allen	
S134	TC054 M8x24	5 Allen	

APXT 1003

KRLY ucuna uygundur.



Sipariş Kodu	Ürün Kodu	Ölçüler (mm)							Uç	Fiyat
		D	Z	M	L	L1	L2	kg		
VT136	D16 Z02 M08 APXT 10	16	2	M08	41	25	16	0,050		₺1.188
VT138	D20 Z03 M10 APXT 10	20	3	M10	55	35	20	0,097	APXT 1003	₺1.290
VT140	D25 Z03 M12 APXT 10	25	3	M12	55	33	22	0,135	KRLY.	₺1.290
VT143	D32 Z04 M16 APXT 10	32	4	M16	60	36	24,5	0,195		₺1.365
VT146	D35 Z04 M16 APXT 10	35	4	M16	60	36	24,5	0,225		₺1.365
VT148	D40 Z05 M16 APXT 10	40	5	M16	60	36	24,5	0,266		₺1.513
VT150	D42 Z05 M16 APXT 10	42	5	M16	60	36	24,5	0,294		₺1.513

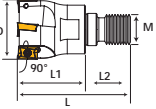
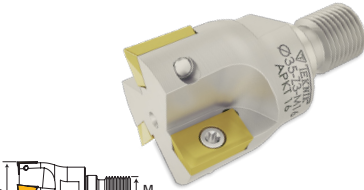



APKT 1604

KRLY ucuna uygundur.

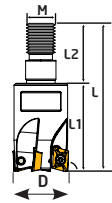
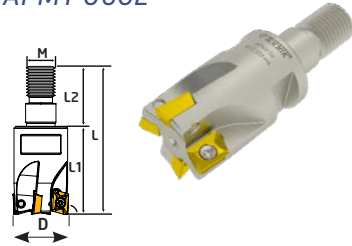

Sipariş Kodu	Ürün Kodu	Ölçüler (mm)							Uç	Fiyat
		D	Z	M	L	L1	L2	kg		
VT160	D25 Z02 M12 APKT 16	25	2	M12	55	33	22	0,107		₺1.188
VT163	D32 Z03 M16 APKT 16	32	3	M16	60	24	24,5	0,180	APKT 1604	₺1.290
VT166	D35 Z03 M16 APKT 16	35	3	M16	60	24	24,5	0,211	KRLY.	₺1.290
VT168	D40 Z04 M16 APKT 16	40	4	M16	60	24	24,5	0,238		₺1.365
VT170	D42 Z04 M16 APKT 16	42	4	M16	60	24	24,5	0,251		₺1.365





APMT 0602

KRLY ucuna uygundur.

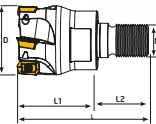
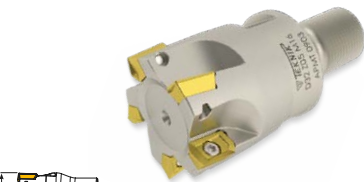

Sipariş Kodu	Ürün Kodu	Ölçüler (mm)							Uç	Fiyat
		D	Z	M	L	L1	L2	kg		
VT220	D10 Z02 M06 APMT 06	10	2	M06	41	25	16	0,011		₺1.188
VT221	D12 Z03 M06 APMT 06	12	3	M06	40	25	15	0,015	APMT 0603	₺1.290
VT222	D16 Z04 M08 APMT 06	16	4	M08	42	25	17	0,030	KRLY.	₺1.365
VT223	D20 Z05 M10 APMT 06	20	5	M10	51	31	20	0,064		₺1.513





APMT 0903

KRLY ucuna uygundur.

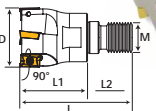

Sipariş Kodu	Ürün Kodu	Ölçüler (mm)							Uç	Fiyat
		D	Z	M	L	L1	L2	kg		
VT224	D16 Z02 M08 APMT 09	16	2	M08	41	25	16	0,040		₺1.188
VT225	D20 Z03 M10 APMT 09	20	3	M10	48	30	18	0,071	APMT 0903	₺1.290
VT226	D25 Z04 M12 APMT 09	25	4	M12	57	35	22	0,116	KRLY.	₺1.365
VT227	D32 Z05 M16 APMT 09	32	5	M16	65,3	40	25,3	0,229		₺1.513
VT228	D35 Z05 M16 APMT 09	35	5	M16	65,3	40	25,3	0,261		₺1.513
VT229	D40 Z06 M16 APMT 09	40	6	M16	65,3	40	25,3	0,299		₺1.786













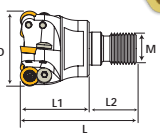



ADMX 0702





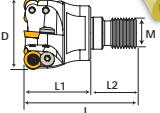

PRMT ucuna uygundur.

Sipariş Kodu	Ürün Kodu	Ölçüler (mm)							Uç	Fiyat
		D	Z	M	L	L1	L2	kg		
VT200	D16 Z04 M08 ADMX 07	16	4	M08	41	23	18	0,041	ADMX 0702	₺1.365
VT201	D20 Z05 M10 ADMX 07	20	5	M10	49	30	19	0,080	PRMT.	₺1.513
VT203	D32 Z08 M16 ADMX 07	32	8	M16	66	43	23	0,235		₺1.910



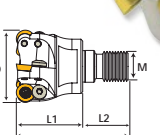





RDMT 1003	Sipariş Kodu	Ürün Kodu	Ölçüler (mm)							Uç	Fiyat
			D	Z	M	L	L1	L2			
	VT098	D20 Z02 M10 RDMT 10	20	2	M10	55	35	20	0,087		₺1.188
	VT100	D25 Z03 M12 RDMT 10	25	3	M12	55	33	22	0,114	RDMT 1003	₺1.290
	VT103	D32 Z03 M16 RDMT 10	32	3	M16	60	35,5	24,5	0,188	ISO.	₺1.290
	VT106	D35 Z04 M16 RDMT 10	35	4	M16	60	35,5	24,5	0,201		₺1.365
	VT107	D35 Z05 M16 RDMT 10	35	5	M16	60	35,5	24,5	0,211		₺1.513
	VT108	D40 Z05 M16 RDMT 10	40	5	M16	60	35,5	24,5	0,241		₺1.513
	VT110	D42 Z05 M16 RDMT 10	42	5	M16	60	35,5	24,5	0,265		₺1.513
	Kod										
	VT098	TC071 M3,5x7	TC040 M3,5		T15						
	VT100-VT110	TC067 M3,5x8,5									



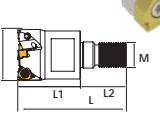

RDMT 12T3	Sipariş Kodu	Ürün Kodu	Ölçüler (mm)							Uç	Fiyat
			D	Z	M	L	L1	L2			
	VT120	D25 Z02 M12 RDMT 12	25	2	M12	55	33	22	0,106		₺1.188
	VT123	D32 Z03 M16 RDMT 12	32	3	M16	60	35,5	24,5	0,177	RDMT 12T3	₺1.290
	VT126	D35 Z03 M16 RDMT 12	35	3	M16	60	35,5	24,5	0,196	ISO.	₺1.290
	VT128	D40 Z04 M16 RDMT 12	40	4	M16	60	35,5	24,5	0,230		₺1.365
	VT130	D42 Z04 M16 RDMT 12	42	4	M16	60	35,5	24,5	0,237		₺1.365
											
			TC067 M3,5x8,5	TC040 M3,5	T15						

RPMT 10-12	Sipariş Kodu	Ürün Kodu	Ölçüler (mm)							Uç	Fiyat
			D	Z	M	L	L1	L2			
	VT180	D25 Z03 M12 RPMT 10	25	3	M12	55	33	22	0,084	RPMT 10	₺1.290
	VT182	D32 Z03 M16 RPMT 10	32	3	M16	68	36	24,5	0,189	MTSBSH.	₺1.290
	VT174	D25 Z02 M12 RPMT 12	25	2	M12	55	33	22	0,109	RPMT 12	₺1.188
	VT176	D32 Z03 M16 RPMT 12	32	3	M16	60	34,7	25,3	0,164	MTSBSH.	₺1.290
	Kod										
	VT180-VT182	TC067 M3,5x8,5	TC040 M3,5		T15						
	VT174-VT176	TC067 M3,5x9	-----								

MTSBSH ucuna uygundur.

XNEX 0403	Sipariş Kodu	Ürün Kodu	Ölçüler (mm)							Uç	Fiyat
			D	Z	M	L	L1	L2			
	VT245	D20 Z03 M10 XNEX 04	20	3	M10	46	28	18	0,073		₺1.365
	VT247	D25 Z04 M12 XNEX 04	25	4	M12	52	30	22	0,115	XNEX 0403	₺1.489
	VT249	D32 Z05 M16 XNEX 04	32	5	M16	65	40	25	0,253	SCO	₺1.836
											
			TC061 M2,5x7	T8							

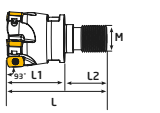
SCO ucuna uygundur.

EPMT 0603	Sipariş Kodu	Ürün Kodu	Ölçüler (mm)							Uç	Fiyat
			D	Z	M	L	L1	L2			
	VT230	D16 Z02 M08 EPMT 06	16	2	M08	41	16	25	0,040		₺1.188
	VT231	D20 Z03 M10 EPMT 06	20	3	M10	48	18	30	0,070		₺1.290
	VT232	D25 Z04 M12 EPMT 06	25	4	M12	55	20	35	0,110	EPMT 0603	₺1.365
	VT233	D32 Z05 M16 EPMT 06	32	5	M16	60	25,3	34,7	0,197	HTCH.	₺1.513
	VT234	D35 Z05 M16 EPMT 06	35	5	M16	60	25,3	34,7	0,224		₺1.513
	VT235	D40 Z06 M16 EPMT 06	40	6	M16	60	25,3	34,7	0,256		₺1.786
	VT236	D42 Z06 M16 EPMT 06	42	6	M16	65,3	25,3	40	0,300		₺1.786
											
			TC060 M2,5x5,5	T7							

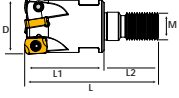

HTCH ucuna uygundur.

LNMX 0603



KRLY ucuna uygundur.

Sipariş Kodu	Ürün Kodu	Ölçüler (mm)							Uç	Fiyat
		D	Z	M	L	L1	L2	kg		
VT152	D16 Z02 M08 LNMX 06	16	2	M08	42	25	17	0,031		₺1.094
VT153	D20 Z03 M10 LNMX 06	20	3	M10	51	30	21	0,060	LNMX 0603	₺1.290
VT154	D25 Z04 M12 LNMX 06	25	4	M12	59	35	24	0,120	KRLY	₺1.365
VT155	D32 Z05 M16 LNMX 06	32	5	M16	67	40	27	0,227		₺1.513

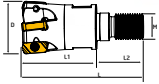

 TC065-1M3x7
  T8
 

LNMU 0303



TNGLY-OKE ucuna uygundur.

Sipariş Kodu	Ürün Kodu	Ölçüler (mm)							Uç	Fiyat
		D	Z	M	L	L1	L2	kg		
VT300	D16 Z02 M08 LNMU 03	16	2	M08	42	25	17	0,029		₺1.094
VT302	D20 Z03 M10 LNMU 03	20	3	M10	49	30	19	0,061	LNMU 0303	₺1.290
VT304	D25 Z04 M12 LNMU 03	25	4	M12	57	35	22	0,108	TNGLY-OKE	₺1.365
VT305	D32 Z05 M16 LNMU 03	32	5	M16	63	40	23	0,227		₺1.513
VT307	D40 Z06 M16 LNMU 03	40	6	M16	63	40	23	0,272		₺1.788

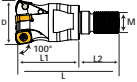

 TC065 M2,5x7
  T8
 

BLMP 0603



TGTC ucuna uygundur.

Sipariş Kodu	Ürün Kodu	Ölçüler (mm)							Uç	Fiyat
		D	Z	M	L	L1	L2	kg		
VT190	D16 Z02 M08 BLMP 06	16	2	M08	41	25	16	0,044		₺1.188
VT191	D20 Z03 M10 BLMP 06	20	3	M10	48	30	18	0,081	BLMP 0603	₺1.290
VT192	D25 Z04 M12 BLMP 06	25	4	M12	57	35	22	0,119	TGTC	₺1.365
VT193	D32 Z05 M16 BLMP 06	32	5	M16	65	40	25	0,233		₺1.513
VT194	D35 Z05 M16 BLMP 06	35	5	M16	65	40	25	0,240		₺1.513
VT195	D40 Z06 M16 BLMP 06	40	6	M16	68	43	25	0,291		₺1.786
VT196	D42 Z06 M16 BLMP 06	42	6	M16	68	43	25	0,313		₺1.786

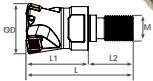

 TC064 M3x6,5
  T8
 

SDMT 09T3











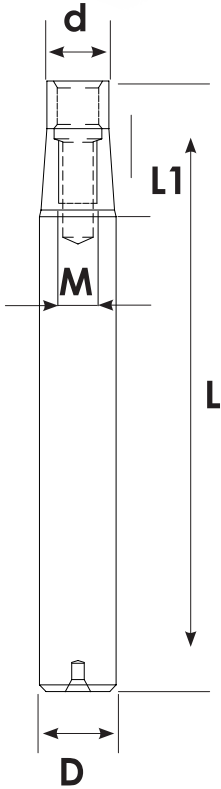





ZCC ucuna uygundur.

Sipariş Kodu	Ürün Kodu	Ölçüler (mm)							Uç	Fiyat
		D	Z	M	L	L1	L2	kg		
VT240	D32 Z03 M16 SDMT 09	32	3	M16	69	40	29	0,211	SDMT 09T3	₺1.290
VT241	D35 Z03 M16 SDMT 09	35	3	M16	69	40	29	0,231	ZCC	₺1.290
VT242	D40 Z04 M16 SDMT 09	40	3	M16	69	40	29	0,253		₺1.290

 TC067 M3,5x8,5
  T15
 

Vidalı Takım Tutucu



Sipariş Kodu	Ürün Kodu	Ölçüler (mm)							Fiyat
		D	d	L	L1	M			
VT500	D15 d12 L150 M8	15	12,7	150	30	M8	0,208	₺1.115	
VT501	D15 d12 L150 M8-IC 	15	12,7	150	30	M8	0,202	₺1.169	
VT502	D16 d14 L100 M8	16	14	100	30	M8	0,153	₺1.041	
VT503	D16 d14 L100 M8-IC 	16	14	100	30	M8	0,150	₺1.090	
VT504	D16 d14 L150 M8	16	14	150	30	M8	0,234	₺1.115	
VT505	D16 d14 L150 M8-IC 	16	14	150	30	M8	0,230	₺1.169	
VT506	D19 d17 L150 M10	19	17,7	150	30	M10	0,329	₺1.115	
VT507	D19 d17 L150 M10-IC 	19	17,7	150	30	M10	0,324	₺1.169	
VT508	D20 d17 L100 M10	20	17,7	100	30	M10	0,238	₺1.041	
VT509	D20 d17 L100 M10-IC 	20	17,7	100	30	M10	0,235	₺1.090	
VT510	D20 d17 L150 M10	20	17,7	150	40	M10	0,357	₺1.115	
VT511	D20 d17 L150 M10-IC 	20	17,7	150	40	M10	0,354	₺1.169	
VT512	D24 d20 L150 M12	24	20,7	150	40	M12	0,508	₺1.218	
VT513	D24 d20 L150 M12-IC 	24	20,7	150	40	M12	0,502	₺1.290	
VT514	D25 d20 L150 M12	25	20,7	150	40	M12	0,546	₺1.218	
VT515	D25 d20 L150 M12-IC 	25	20,7	150	40	M12	0,542	₺1.290	
VT516	D25 d20 L200 M12	25	20,7	200	40	M12	0,680	₺1.290	
VT517	D25 d20 L200 M12-IC 	25	20,7	200	40	M12	0,675	₺1.365	
VT518	D25 d20 L250 M12	25	20,7	250	40	M12	0,700	₺1.440	
VT519	D25 d20 L250 M12-IC 	25	20,7	250	40	M12	0,695	₺1.513	
VT520	D32 d28 L170 M16	32	28,7	170	40	M16	0,790	₺1.315	
VT521	D32 d28 L170 M16-IC 	32	28,7	170	40	M16	0,784	₺1.388	
VT522	D32 d28 L220 M16	32	28,7	220	40	M16	0,860	₺1.540	
VT523	D32 d28 L220 M16-IC 	32	28,7	220	40	M16	0,854	₺1.614	
VT524	D32 d28 L300 M16	32	28,7	300	40	M16	1,380	₺1.684	
VT525	D32 d28 L300 M16 -IC 	32	28,7	300	40	M16	1,375	₺1.764	

İK İşten Su Vermelidir.

Diş Çap Diş Katerleri/R

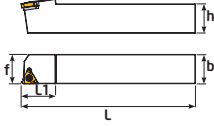

Sipariş Kodu	Ürün Kodu	Ölçüler (mm)						Uç	Fiyat
		h	b	f	L	L1	kg		
D261	AL 1212 J16- ER16	12	12	16	110	20	0,140		₺646
D259	AL 1616 H16- ER16	16	16	16	100	22	0,250	16 ER	₺646
D258	AL 2020 K16- ER16	20	20	20	125	25	0,410		₺676
D260	AL 2525 M16- ER16	25	25	25	150	30	0,750		₺725
D262	AL 3232 P16- ER16	32	32	32	170	30	1,430		₺879
D265	AL 2020 K22- ER22	20	20	20	125	30	0,458	22 ER	₺676
D266	AL 2525 M22- ER22	25	25	25	150	30	0,740	22 ER	₺725

Kod	TC068 M3,5x11	TA040	TC048 M5	T15
D261-D262	TC068 M3,5x11	TA040	TC048 M5	T15
D266	TC078 M4x11	--	--	--

Diş Çap Diş Katerleri/L



Sipariş Kodu	Ürün Kodu	Ölçüler (mm)						Uç	Fiyat
		h	b	f	L	L1	kg		
D268	AL 2020 K16 - L IR16	20	20	20	125	25	0,410		₺676
D269	AL 2525 M16 - L IR16	25	25	25	150	30	0,754	16 IR	₺725
D266-1	AL 2525 M22 - L IR22	25	25	25	150	30	0,748	22 IR	₺725

Kod	TC068 M3,5x11	TA040	TC048 M5	T15
D268-D269	TC068 M3,5x11	TA040	TC048 M5	T15
D266-1	TC078 M4x11	--	--	--

İç Çap Diş Katerleri/R

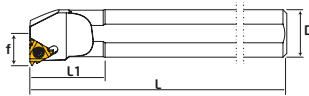

Sipariş Kodu	Ürün Kodu	Ölçüler (mm)					Delik Çapı	kg	Uç	Fiyat
		D	L	L1	f	Dmin				
K348	S10J STIR- IR11	10	110	20	6	12	0,079		₺510	
K350	S12K STIR- IR11	12	125	25	7,2	14	0,117	11 IR	₺519	
K352	S16Q STIR- IR16	16	180	40	11	20	0,286		₺619	
K354	S20Q STIR- IR16	20	180	40	13	25	0,436	16 IR	₺646	
K356	S25R STIR- IR16	25	200	40	16	29	0,762		₺796	
K358	S32T STIR- IR16	32	300	60	19,5	36	1,829		₺1.219	
K358-1	S20Q STIR- IR22	20	180	40	14	24	0,431		₺646	
K359	S25R STIR- IR22	25	200	40	17	32	0,757	22 IR	₺796	
K360	S32T STIR- IR22	32	300	60	19,5	36	1,818		₺1.219	
K360-1	S40T STIR- IR22	40	300	60	24,5	45	2,831		₺1.788	

Kod	TC060 M2,5x5,5	TC067 M3,5x8,5	TC078 M4x11	T8	T10	T15
K348-K350	TC060 M2,5x5,5	TC067 M3,5x8,5	TC078 M4x11	T8	T10	T15
K352-K358	TC067 M3,5x8,5	TC078 M4x11	TC078 M4x11	T10	T15	T15
K358-1-K360-1	TC078 M4x11	TC078 M4x11	TC078 M4x11	T15	T15	T15

İç Çap Diş Katerleri/L

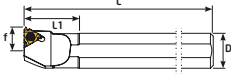

Sipariş Kodu	Ürün Kodu	Ölçüler (mm)					Delik Çapı	kg	Uç	Fiyat
		D	L	L1	f	Dmin				
K360-2	S10J STIL-ER11	10	110	20	6	12	0,079	11 ER	₺510	
K361	S16Q STIL-ER16	16	180	40	11	20	0,286		₺619	
K362	S20Q STIL-ER16	20	180	40	13	25	0,436	16 ER	₺646	
K363	S25R STIL-ER16	25	200	40	16	29	0,762		₺796	

Kod	TC060 M2,5x5,5	TC067 M3,5x8,5	T8	T10
K360-2	TC060 M2,5x5,5	TC067 M3,5x8,5	T8	T10
K361-K363	TC067 M3,5x8,5	TC067 M3,5x8,5	T10	T10

Diş Çap Diş Katerleri/R

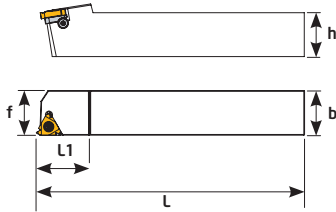

Sipariş Kodu	Ürün Kodu	Ölçüler (mm)						Uç	Fiyat
		h	b	f	L	L1	kg		
D494	SER 0808 H11 - ER11	8	8	11	100	20	0,061		₺756
D495	SER 1010 H11 - ER11	10	10	11	100	20	0,091	11 ER	₺756
D496	SER 1010 M11 - ER11	10	10	11	150	20	0,136		₺793
D497	SER 1212 K11 - ER11	12	12	12	125	20	0,160		₺769
D498	SER 1212 M11 - ER11	12	12	12	150	20	0,193		₺793
D500	SER 1212 J16 - ER16	12	12	16	110	22	0,110		₺725
D501	SER 1616 H16 - ER16	16	16	16	100	25	0,220		₺725
D502	SER 2020 K16 - ER16	20	20	20	125	30	0,410	16 ER	₺753
D503	SER 2525 M16 - ER16	25	25	25	150	30	0,750		₺805
D504	SER 3232 P16 - ER16	32	32	32	170	30	1,410		₺959
D505	SER 2525 M22 - ER22	25	25	25	150	30	0,740		₺879
D506	SER 3232 P22 - ER22	32	32	32	170	30	1,430	22 ER	₺1.013
D507	SER 4040 R22 - ER22	40	40	40	200	36	1,396		₺1.744
D491	SER 2525 M27 - ER27	25	25	32	150	36	2,585		₺1.585
D492	SER 3232 P27 - ER27	32	32	32	170	40	0,791	27 ER	₺1.646
D493	SER 4040 R27 - ER27	40	40	40	200	40	1,405		₺1.901

Kod	TC060 M2,5x5,5	TA061	TA060	TC062 M3	T8
D494-D498	TC060 M2,5x5,5	TA061	TA060	TC062 M3	T8
D500-D504	TC068 M3,5x11	TA062	TA060	TC062 M3	T15
D505-D507	TC077 M4x15	TA064	TA060	TC062 M3	T15
D491-D493	TC086 M5x18	TA064	TA060	TC053 M4	T20

Diş Çap Diş Katerleri/L

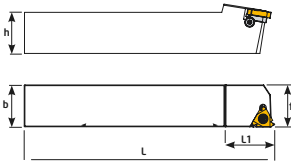



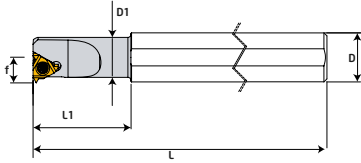

Sipariş Kodu	Ürün Kodu	Ölçüler (mm)						Uç	Fiyat
		h	b	f	L	L1	kg		
D508	SEL 1212 J16 -L- IR16	12	12	16	110	22	0,119		₺725
D509	SEL 1616H16 -L- IR16	16	16	16	100	25	0,223		₺725
D510	SEL 2020 K16 -L- IR16	20	20	20	125	30	0,414	16 IR	₺753
D511	SEL 2525 M16 -L- IR16	25	25	25	150	30	0,753		₺805
D512	SEL 3232 P16 -L- IR16	32	32	32	170	30	1,417		₺959
D513	SEL 2525 M22 -L- IR22	25	25	25	150	30	0,749	22 IR	₺879
D515	SEL 3232 P22 -L- IR22	32	32	32	170	36	1,434		₺1.013

Kod	TC068 M3,5x11	TA060	BSP010	TC062 M3	T15
D508-D512	TC068 M3,5x11	TA060	BSP010	TC062 M3	T15
D513-D515	TC077 M4x15	TA063	BSP010	TC062 M3	T15

İç Çap Diş Katerleri/R



Sipariş Kodu	Ürün Kodu	Ölçüler (mm)					Delik Çapı	kg	Uç	Fiyat
		D	D1	L	L1	f				
K337-1	SIR S12H - IR06	12	5,1	100	12	4,3	6	0,089	6 IR	₺646
K337-2	SIR S16K - IR08	16	6,6	125	18	5,3	7,8	0,195	8 IR	₺646
K337-3	SIR S10H - IR11	10	-	100	20	7,4	12	0,063		₺610
K337-4	SIR S16K - IR11	16	10	125	25	7,4	12	0,167	11 IR	₺646
K337-5	SIR S16L - IR11	16	13	140	32	8,9	15	0,207		₺646
K337-6	SIR S16M - IR16	16	13	150	32	10,2	16	0,221		₺646
K337-7	SIR S20P - IR16	20	16	170	40	11,7	19	0,381		₺704
K338	SIR S20Q - IR16	20	-	180	40	13,4	24	0,440	16 IR	₺704
K339	SIR S25R - IR16	25	-	200	45	16,1	29	0,760		₺796
K340	SIR S32T - IR16	32	-	300	60	21,5	39	1,830		₺1.219
K341	SIR S40T - IR16	40	-	300	60	24,5	45	2,830		₺1.788
K342	SIR S50U - IR16	50	-	350	75	28,7	54	5,337		₺2.031
K342-1	SIR S20P - IR22	20	-	170	40	15,6	24	0,433		₺708
K343	SIR S25R - IR22	25	-	200	45	16,1	30	0,760		₺796
K344	SIR S32T - IR22	32	-	300	40	22	39	1,820	22 IR	₺1.219
K345	SIR S40T - IR22	40	-	300	60	25,6	46	2,840		₺1.788
K346	SIR S50U - IR22	50	-	350	75	30,6	56	5,335		₺2.031
K347	SIR S32S - IR27	32	-	250	60	22,6	40	1,523		₺1.869
K347-1	SIR S40T - IR27	40	-	300	60	26,6	48	2,890	27 IR	₺2.194
K347-2	SIR S50U - IR27	50	-	350	75	31,6	58	5,177		₺2.356
K347-4	SIR S60V - IR27	60	-	400	75	36,6	68	8,700		₺3.575

Kod					
K337-1	TC058 M2x4,2	--	--	--	T6
K337-2	TC058-1 M2x4,6	--	--	--	T8
K337-3-K337-5	TC060 M2,5x5,5	--	--	--	T8
K337-6-K337-7	TC067 M3,5x8,5	--	--	--	T15
K338-K342	TC068 M3,5x11	TA060	BSP010	TC062 M3	T15
K342-1	TC078 M4x11	--	--	--	T15
K343-K346	TC077 M4x15	TA063	BSP010	TC062 M3	T15
K347 - K347-4	TC086 M5x18	TA065	--	TC053M4	T20



İç Çap Diş Katerleri/R
Soğutmalı

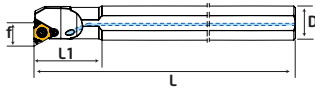

Sipariş Kodu	Ürün Kodu	Ölçüler (mm)					Delik Çapı	Uç	Fiyat
		D	L	L1	f	Dmin			
K327-1	SIR A16K - IR11	16	125	25	7,4	12	0,165	11 IR	₺769
K327-2	SIR A16M - IR16	16	150	32	10,2	16	0,220		₺769
K327-3	SIR A20P - IR16	20	170	40	11,7	19	0,380		₺829
K327-4	SIR A20P - IR16	20	170	40	13,7	24	0,412	16 IR	₺829
K327-5	SIR A25R - IR16	25	200	45	16,2	29	0,710		₺910
K327-6	SIR A25R - IR22	25	200	45	18,1	29	0,730	22 IR	₺959

Kod	TC060 M2,5x5,5	TA060	BSP10	TC062 M3	T15
K327-1	TC060 M2,5x5,5	TA060	BSP10	TC062 M3	T15
K327-2-K327-3	TC067 M3,5x8,5	TA063	BSP10	TC062 M3	T15
K327-4-K327-5	TC068 M3,5x11	TA063	BSP10	TC062 M3	T15
K327-6	TC077 M4x15	TA063	BSP10	TC062 M3	T15

İç Çap Diş Katerleri/L

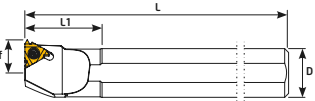



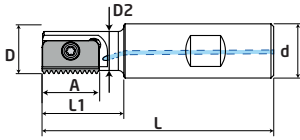

Sipariş Kodu	Ürün Kodu	Ölçüler (mm)					Delik Çapı	Uç	Fiyat
		D	L	L1	f	Dmin			
K330	SIL S20Q - ER16	20	180	40	13,4	24	0,440		₺704
K331	SIL S25R - ER16	25	200	45	16,1	29	0,760		₺796
K332	SIL S32T - ER16	32	300	60	21,5	39	1,830	16ER	₺1.219
K333	SIL S40T - ER16	40	300	60	24,5	45	2,830		₺1.788
K334	SIL S25R - ER22	25	200	45	16,1	30	0,760		₺796
K335	SIL S32T - ER22	32	300	40	22	39	1,820	22ER	₺1.219
K336	SIL S40T - ER22	40	300	60	24,5	50	2,840		₺1.788

Kod	TC068 M3,5x11	TA061	BSP010	TC062 M3	T15
K330-K333	TC068 M3,5x11	TA061	BSP010	TC062 M3	T15
K334-K336	TC077 M4x15	TA062	BSP010	TC062 M3	T15

Diş Açma Takımları Soğutmalı





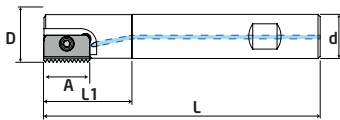

Sipariş Kodu	Ürün Kodu	Ölçüler (mm)							Uç	Fiyat
		A	D	d	D2	L	L1			
DC201	D9,5 d20 L085 A12 S12	12	9,5	20	7,5	85	14	0,195	S12	₺1.244
DC202	D9,9 d20 L085 A12 S12	12	9,9	20	7,6	85	16	0,191	S12	₺1.244
DC203	D12 d20 L075 A14 S14	14	12	20	8,9	75	20	0,156	S14	₺1.244
DC204	D14,5 d20 L085 A14 S14	14	14,5	20	11,2	85	25	0,179	S14	₺1.244
DC205	D17 d20 L085 A14 S14	14	17	20	13,4	85	30	0,180	S14	₺1.244
DC206	D18 d20 L085 A21 S21	21	18	20	14,4	85	30	0,176	S21	₺1.341
DC207	D21 d20 L094 A21 S21	21	21	20	16,5	94	40	0,204	S21	₺1.390
DC208	D29 d25 L110 A30 S30	30	29	25	22,4	110	50	0,390	S30	₺1.511
DC209	D48 d40 L153 A40 S40	40	48	40	35	153	78	1,325	S40	₺1.731

Kod			
DC200-DC202	TC092 M2,5x5,5	T8	
DC203-DC205	TC096 M2,5x7	T15	
DC206-DC207	TC074 M4x10	T20	
DC208	TC256 M5x12		
DC209	TC086 M5x18		

Diş Açma Takımları Soğutmalı





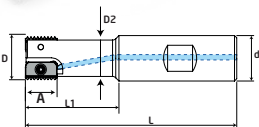

Sipariş Kodu	Ürün Kodu	Ölçüler (mm)					Uç	Fiyat	
		A	D	d	L	L1			
DC210	D25 d20 L125 A21 S21	21	25	20	125	40	0,320	S21	₺1.414
DC211	D31 d25 L150 A30 S30	30	31	25	150	60	0,597	S30	₺1.585
DC212	D38 d32 L150 A30 S30	30	38	32	150	60	1,005	S30	₺1.585
DC213	D48 d40 L210 A40 S40	40	48	40	210	78	2,068	S40	₺1.658

Kod			
DC210	TC074 M4x10	T15	
DC211-DC212	TC256 M5x12		
DC213	TC086 M5x18		

Diş Açma Takımları Soğutmalı



Sipariş Kodu	Ürün Kodu	Ölçüler (mm)							Uç	Fiyat
		A	D	d	D2	L	L1			
DC214	D20 d20 L093 A14 S14	14	20	20	16	93	41	0,202	S14	₺1.865
DC215	D30 d25 L108 A21 S21	21	30	25	24	108	52	0,401	S21	₺1.914
DC216	D40 d32 L130 A30 S30	30	40	32	30	130	70	0,781	S30	₺1.914
DC217	D50 d40 L153 A40 S40	40	50	40	38	153	78	1,455	S40	₺1.999

Kod			
DC214	TC093 M2,5x7	T8	
DC215	TC074 M4x10	T15	
DC216	TC256 M5x12		
DC217	TC086 M5x18		

93° PDJNR IC

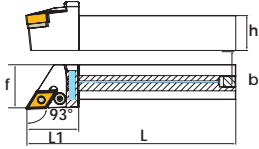
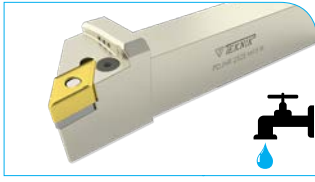

Sipariş Kodu	Ürün Kodu	Ölçüler (mm)						Uç	Fiyat
		L	L1	h	f	b			
AP110	PDJNR 2020 K15-IKG1/8	125	30	20	25	20	0,409	DNMG 1506	₺1.448
AP112	PDJNR 2525 M15-IKG1/8	150	38	25	32	25	0,759	ISO.	₺1.529
Kod									
AP110	TH821	TA014-1	TS-4	TL4B	3 Allen				
AP112	TH825								

93° PDJNL IC

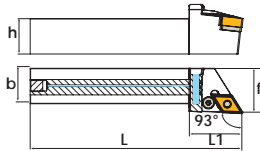
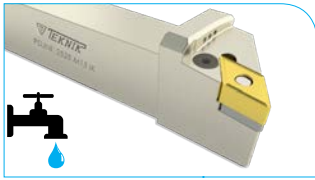

Sipariş Kodu	Ürün Kodu	Ölçüler (mm)						Uç	Fiyat
		L	L1	h	f	b			
AP122	PDJNL 2020 K15-IKG1/8	125	40	20	25	20	0,409	DNMG 1506	₺1.448
AP124	PDJNL 2525 M15-IKG1/8	150	40	25	32	25	0,759	ISO.	₺1.529
Kod									
AP122	TH821	TA014-1	TS-4	TL4B	3 Allen				
AP124	TH825								

95° PCLNR IC

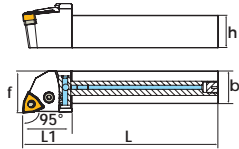

Sipariş Kodu	Ürün Kodu	Ölçüler (mm)						Uç	Fiyat
		L	L1	h	f	b			
AP129	PCLNR 1616 H12-IKG1/8	100	28	16	20	16	0,236	CNMG 1204	₺1.448
AP130	PCLNR 2020 K12-IKG1/8	125	28	20	25	20	0,428	ISO.	₺1.448
AP132	PCLNR 2525 M12-IKG1/8	150	30	25	32	25	0,781		₺1.529
Kod									
AP129	TH818	TA016-1	TS4	TL4	3 Allen				
AP130-AP132	TH821								

95° PCLNL IC

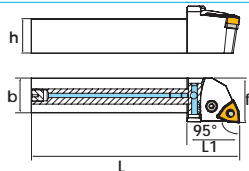

Sipariş Kodu	Ürün Kodu	Ölçüler (mm)						Uç	Fiyat
		L	L1	h	f	b			
AP139	PCLNL 1616 H12-IKG1/8	100	28	16	20	16	0,236		₺1.448
AP140	PCLNL 2020 K12-IKG1/8	125	28	20	25	20	0,428	CNMG 1204	₺1.448
AP142	PCLNL 2525 M12-IKG1/8	150	30	25	32	25	0,781	ISO.	₺1.529
Kod									
AP139	TH818	TA016-1	TS4	TL4	3 Allen				
AP140-AP142	TH821								

95° PWLNR 08 IC

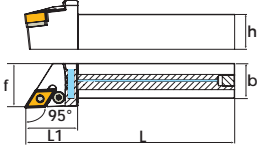

Sipariş Kodu	Ürün Kodu	Ölçüler (mm)						Uç	Fiyat
		L	L1	h	f	b	kg		
AP150	PWLNR 2020 K08-IKG1/8	125	30	20	25	20	0,425	WNMG 0804	₺1.448
AP151	PWLNR 2525 M08-IKG1/8	150	38	25	32	25	0,782	ISO.	₺1.529

95° PWLNL 08 IC

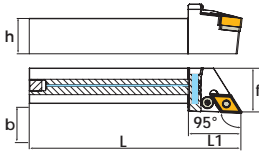

Sipariş Kodu	Ürün Kodu	Ölçüler (mm)						Uç	Fiyat
		L	L1	h	f	b	kg		
AP155	PWLNL 2020 K08-IKG1/8	125	30	20	25	20	0,425	WNMG 0804	₺1.448
AP156	PWLNL 2525 M08-IKG1/8	150	38	25	32	25	0,782	ISO.	₺1.529

95° PWLNR 06 IC

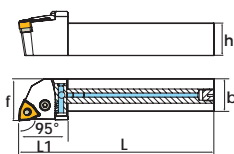

Sipariş Kodu	Ürün Kodu	Ölçüler (mm)						Uç	Fiyat
		L	L1	h	f	b	kg		
AP158	PWLNR 1616 H06-IKG1/8	100	30	16	20	16	0,218		₺1.448
AP160	PWLNR 2020 K06-IKG1/8	125	30	20	25	20	0,415	WNMG 0604	₺1.448
AP161	PWLNR 2525 M06-IKG1/8	150	30	25	32	25	0,756	ISO.	₺1.529

95° PWLNL 06 IC

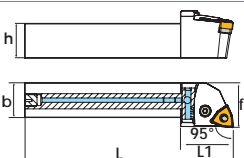



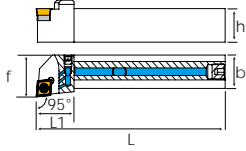

Sipariş Kodu	Ürün Kodu	Ölçüler (mm)						Uç	Fiyat
		L	L1	h	f	b	kg		
AP164	PWLNL 1616 H06-IKG1/8	100	30	16	20	16	0,218		₺1.448
AP165	PWLNL 2020 K06-IKG1/8	125	30	20	25	20	0,415	WNMG 0604	₺1.448
AP166	PWLNL 2525 M06-IKG1/8	150	30	25	32	25	0,756	ISO.	₺1.529

95° SCLCR IC







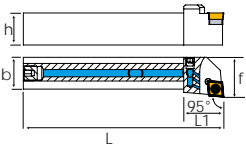
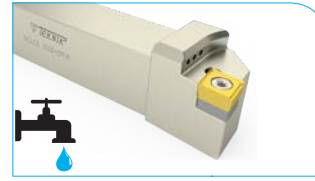

Sipariş Kodu	Ürün Kodu	Ölçüler (mm)						Uç	Fiyat
		L	L1	h	f	b			
AP500	SCLCR 1616 H09-İK	100	25	16	20	16	0,205	CCMT 09T3	₺1.448
AP501	SCLCR 2020 K09-İK	125	25	20	25	20	0,418	ISO.	₺1.448
AP502	SCLCR 2020 K12-İK	125	30	20	25	20	0,370	CCMT 1204	₺1.448
AP503	SCLCR 2525 M12-İK	150	30	25	32	25	0,771		₺1.475

Kod					
AP500-AP501	TC068 M3,5x11	TA015	TC048 M5		
AP502-AP503	TC075 M4x11	TA15-1	TC049-1M6	T15	

95° SCLCL IC







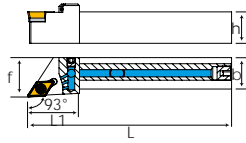

Sipariş Kodu	Ürün Kodu	Ölçüler (mm)						Uç	Fiyat
		L	L1	h	f	b			
AP505	SCLCL 1616 H09-İK	100	25	16	20	16	0,205	CCMT 09T3	₺1.448
AP506	SCLCL 2020 K09-İK	125	25	20	25	20	0,418	ISO.	₺1.448
AP507	SCLCL 2020 K12-İK	125	30	20	25	20	0,375	CCMT 1204	₺1.448
AP508	SCLCL 2525 M12-İK	150	30	25	32	25	0,771		₺1.475

Kod					
AP505-AP506	TC068 M3,5x11	TA015	TC048 M5		
AP508	TC075 M4x11	TA15-1	TC049-1 M6	T15	

93° SDJCR IC







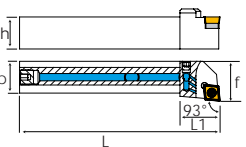

Sipariş Kodu	Ürün Kodu	Ölçüler (mm)						Uç	Fiyat
		L	L1	h	f	b			
AP509	SDJCR 1212 J11-İK	110	32	12	16	12	0,107	DCMT 11T3	₺1.448
AP510	SDJCR 1616 H11-İK	100	32	16	20	16	0,204	ISO.	₺1.448
AP511	SDJCR 2020 K11-İK	125	32	20	25	20	0,404		₺1.448
AP512	SDJCR 2525 M11-İK	150	35	25	32	25	0,735		₺1.475

					
	TC068 M3,5x11	TA030	TC048 M5	T8	

93° SDJCL IC







Sipariş Kodu	Ürün Kodu	Ölçüler (mm)						Uç	Fiyat
		L	L1	h	f	b			
AP514	SDJCL 1212 J11-İK	110	32	12	16	12	0,107	DCMT 11T3	₺1.448
AP515	SDJCL 1616 H11-İK	100	32	16	16	16	0,204	ISO.	₺1.448
AP516	SDJCL 2020 K11-İK	125	32	20	25	20	0,404		₺1.448
AP517	SDJCL 2525 M11-İK	150	35	25	32	25	0,735		₺1.475

					
	TC068 M3,5x11	TA030	TC048 M5	T8	

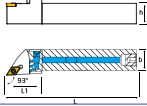
**NEW
PRODUCT**

93° SDJCR IC





Sipariş Kodu	Ürün Kodu	Ölçüler (mm)						Uç	Fiyat
		L	L1	h	f	b	kg		
AP560	SDJCR 1212 K07-IC	125	27	12	16	12	0,175		₺1.424
AP561	SDJCR 1616 H07-IC	100	27	16	20	16	0,210	DCMT 0702	₺1.448
AP562	SDJCR 2020 K07-IC	125	27	20	25	20	0,400	ISO.	₺1.448
Kod									
AP560-AP562		TC060 M2,5x5,5		T8					

**NEW
PRODUCT**

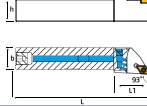
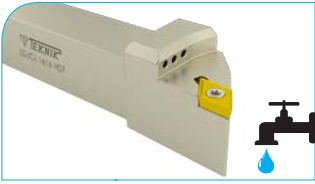
93° SDJCL IC





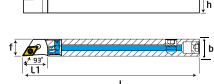

Sipariş Kodu	Ürün Kodu	Ölçüler (mm)						Uç	Fiyat
		L	L1	h	f	b	kg		
AP565	SDJCL 1212 K07-IC	125	16	16	12	16	0,175		₺1.424
AP566	SDJCL 1616 H07-IC	100	27	16	20	16	0,210	DCMT 0702	₺1.448
AP567	SDJCL 2020 K07-IC	125	27	20	25	20	0,400	ISO.	₺1.448
Kod									
AP565-AP567		TC060 M2,5x5,5		T8					

**NEW
PRODUCT**

93° SDJCR -F IC





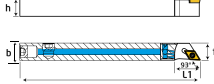
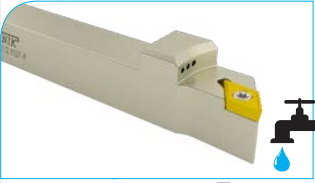

Sipariş Kodu	Ürün Kodu	Ölçüler (mm)						Uç	Fiyat
		L	L1	h	f	b	kg		
AP569	SDJCR 1212 K07-F-IC	125	27	12	16	12	0,175	ISO.	₺1.424
AP570	SDJCR 1616 H07-F-IC	100	27	16	16	16	0,210	DCMT 0702	₺1.448
AP571	SDJCR 1212 J11-F-IC	110	32	12	12	12	0,106	DCMT 11T3	₺1.424
AP572	SDJCR 1616 H11-F-IC	100	32	16	16	16	0,167		₺1.448
Kod									
AP569-AP570		TC060 M2,5x5,5	---	---	T8				
AP571-AP572		TC067 M3,5x8,5	TA030	TC048 M5	T15				

**NEW
PRODUCT**

93° SDJCL-F IC



Sipariş Kodu	Ürün Kodu	Ölçüler (mm)						Uç	Fiyat
		L	L1	h	f	b	kg		
AP573	SDJCL 1212 K07 F-IC	125	27	12	12	12	0,175	ISO.	₺1.424
AP574	SDJCL 1616 H07-F-IC	100	27	16	16	16	0,210	DCMT 0702	₺1.448
AP575	SDJCL 1212 J11-F-IC	110	32	12	12	12	0,106	DCMT 11T3	₺1.424
Kod									
AP573-AP574		TC060 M2,5x5,5	---	---	T8				
AP575		TC067 M3,5x8,5	TA030	TC048 M5	T15				

93° SVJBR IC

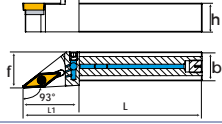

Sipariş Kodu	Ürün Kodu	Ölçüler (mm)						Uç	Fiyat
		L	L1	h	f	b			
AP540	SVJBR 1010 J11-İK	110	30	10	12	10	0,097	VBMT 1103	₺1.424
AP541	SVJBR 1212 J11-İK	110	32	12	16	12	0,141	ISO.	₺1.424
AP545	SVJBR 2020 K16-İK	125	40	20	25	20	0,192	VBMT 1604	₺1.448
AP546	SVJBR 2525 M16-İK	150	40	25	32	25	0,192	ISO.	₺1.475
Kod									
AP540-AP541 AP545-AP546		TC061 M2,5x6,5 TC068 M3,5x11	---	TA034	---	TC048	T8 T15		

93° SVJBL IC

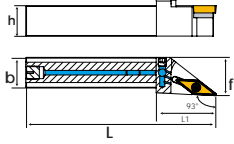

Sipariş Kodu	Ürün Kodu	Ölçüler (mm)						Uç	Fiyat
		L	L1	h	f	b			
AP550	SVJBL 1010 J11-İK	110	30	10	12	10	0,097	VBMT 1103	₺1.424
AP551	SVJBL 1212 J11-İK	110	32	12	16	12	0,141	ISO.	₺1.424
AP552	SVJBL 1616 H11-İK	100	35	16	20	16	0,167		₺1.448
AP555	SVJBL 2020 K16-İK	125	40	20	25	20	0,192	VBMT 1604	₺1.448
AP556	SVJBL 2525 M16-İK	150	40	25	32	25	0,192	ISO.	₺1.475
Kod									
AP550-AP552 AP555-AP556		TC061 M2,5x6,5 TC068 M3,5x11	---	TA034	---	TC048	T8 T15		

93° SVJCR IC

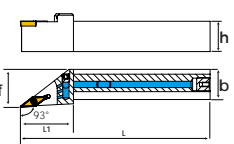
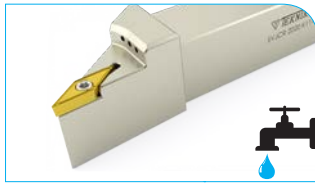

Sipariş Kodu	Ürün Kodu	Ölçüler (mm)						Uç	Fiyat
		L	L1	h	f	b			
AP519	SVJCR 1212 J11-İK	110	32	12	16	12	0,109	VCMT 1103	₺1.424
AP520	SVJCR 1616 H11-İK	100	25	16	20	16	0,204	ISO.	₺1.448
AP521	SVJCR 2020 K11-İK	125	33	20	25	20	0,378		₺1.448
AP522	SVJCR 2525 M11-İK	150	40	25	32	25	0,690		₺1.475
AP525	SVJCR 2020 K16-İK	125	33	20	25	20	0,385	VCMT 1604	₺1.448
AP526	SVJCR 2525 M16-İK	150	40	25	32	25	0,683	ISO.	₺1.475
Kod									
AP519-AP522 AP525-AP526		TC061 M2,5x6,5 TC068 M3,5x11	---	TA034	---	TC048	T8 T15		

93° SVJCL IC

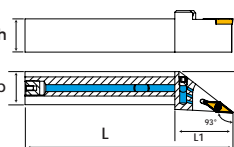
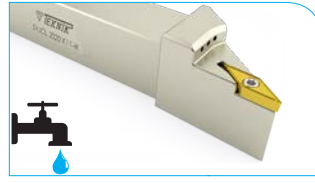

Sipariş Kodu	Ürün Kodu	Ölçüler (mm)						Uç	Fiyat
		L	L1	h	f	b			
AP529	SVJCL 1212 J11-İK	110	32	12	16	12	0,109	VCMT 1103	₺1.424
AP530	SVJCL 1616 H11-İK	100	25	16	20	16	0,204	ISO.	₺1.448
AP531	SVJCL 2020 K11-İK	125	33	20	25	20	0,378		₺1.448
AP532	SVJCL 2525 M11-İK	150	40	25	32	25	0,627		₺1.475
AP535	SVJCL 2020 K16-İK	125	33	20	25	20	0,385	VCMT 1604	₺1.448
AP536	SVJCL 2525 M16-İK	150	40	25	32	25	0,683	ISO.	₺1.475
Kod									
AP529-AP532 AP535-AP536		TC061 M2,5x6,5 TC068 M3,5x11	---	TA034	---	TC048	T8 T15		

93° SVJBR-F IC

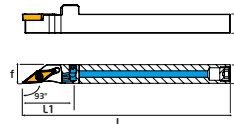
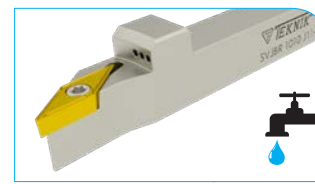

Sipariş Kodu	Ürün Kodu	Ölçüler (mm)						Uç	Fiyat
		h	b	f	L	L1			
AP547	SVJBR 1010 J11-F-İK	10	10	10	110	30	0,72	VBMT 1103	₺1.424
AP548	SVJBR 1212 J11-F-İK	12	12	12	110	32	0,105	ISO.	₺1.424
AP549	SVJBR 1616 H11-F-İK	16	16	16	100	35	0,160		₺1.448
Kod									
AP547 - AP549		TC061 M2,5x6,5					T8		

93° SVJBL-F IC

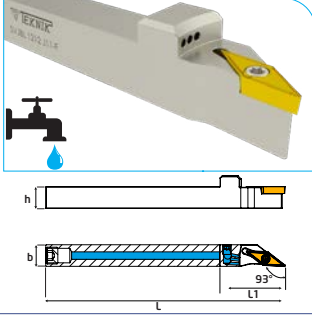

Sipariş Kodu	Ürün Kodu	Ölçüler (mm)						Uç	Fiyat
		L	L1	h	f	b			
AP557	SVJBL 1010 J11-F-İK	110	30	10	10	10	0,72	VBMT 1103	₺1.424
AP558	SVJBL 1212 J11-F-İK	110	32	12	12	12	0,105	ISO.	₺1.424
Kod									
AP557-AP558		TC061 M2,5x6,5		T8					

93° SVJCR-F IC

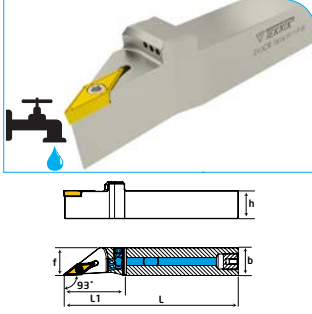

Sipariş Kodu	Ürün Kodu	Ölçüler (mm)						Uç	Fiyat
		L	L1	h	f	b			
AP527	SVJCR 1212 J11-F-İK	110	32	12	12	12	0,102	VCMT 1103	₺1.424
AP528	SVJCR 1616 H11-F-İK	100	35	16	16	16	0,185	ISO.	₺1.448
Kod									
AP527-AP528		TC061 M2,5x6,5		T8					

93° SVJCL-F IC

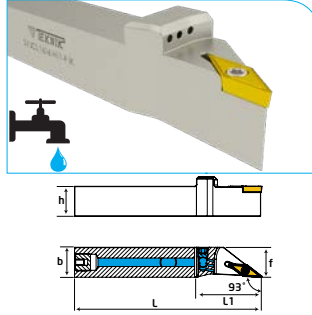

Sipariş Kodu	Ürün Kodu	Ölçüler (mm)						Uç	Fiyat
		L	L1	h	f	b			
AP537	SVJCL 1212 J11-F-İK	110	32	12	12	12	0,102	VCMT 1103	₺1.424
AP538	SVJCL 1616 H11-F-İK	100	35	16	16	16	0,185	ISO.	₺1.448
Kod									
AP537-AP538		TC061 M2,5x6,5		T8					

Dış Çap Diş Katerleri IC

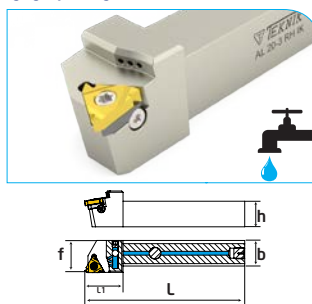

Sipariş Kodu	Ürün Kodu	Ölçüler (mm)						Uç	Fiyat
		h	b	f	L	L1			
AP602	SER 2020 K16 - ER16 İK	20	20	20	125	30	0,449	16 ER	₺1.390
AP604	SER 2525 M16 - ER16 İK	25	25	25	150	30	0,842		₺1.463
TC068 M3,5x11		TA061		TA060		TC062 M3		T15	

93° PDJNR

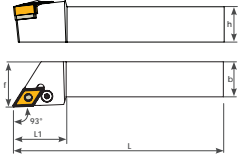
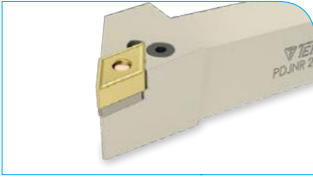

Sipariş Kodu	Ürün Kodu	Ölçüler (mm)						Uç	Fiyat
		L	L1	h	f	b	kg		
P107	PDJNR 1616 H11	100	25	16	25	16	0,242	DNMG 1104	₺879
P108	PDJNR 2020 K11	125	30	20	25	20	0,435	ISO.	₺879
P109	PDJNR 2525 M11	150	30	25	32	25	0,767		₺906
P110	PDJNR 2020 K15	125	35	20	25	20	0,402		₺879
P112	PDJNR 2525 M15	150	38	25	32	25	0,730	DNMG 1506	₺906
P114	PDJNR 3232 P15	170	38	32	40	32	1,384	ISO.	₺1.036

Kod	TH613	TA013	TS-3	TL3	2,5 Allen
P107	TH613	TA013	TS-3	TL3	2,5 Allen
P108-P109	TH617	TA013	TS-3	TL3	2,5 Allen
P110	TH821	TA014-1	TS-4	TL4B	3 Allen
P112-P114	TH825	TA014-1	TS-4	TL4B	3 Allen

93° PDJNL

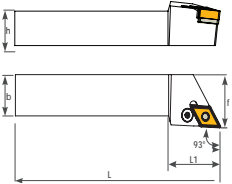
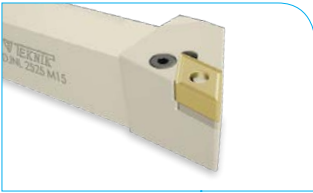

Sipariş Kodu	Ürün Kodu	Ölçüler (mm)						Uç	Fiyat
		L	L1	h	f	b	kg		
P119	PDJNL 1616 H11	100	25	16	25	16	0,242	DNMG 1104	₺879
P120	PDJNL 2020 K11	125	30	20	25	20	0,435	ISO.	₺879
P121	PDJNL 2525 M11	150	30	25	32	25	0,767		₺906
P122	PDJNL 2020 K15	125	35	20	25	20	0,402		₺879
P124	PDJNL 2525 M15	150	38	25	32	25	0,730	DNMG 1506	₺906
P126	PDJNL 3232 P15	170	38	32	40	32	1,384	ISO.	₺1.036

Kod	TH613	TA013	TS-3	TL3	2,5 Allen
P119	TH613	TA013	TS-3	TL3	2,5 Allen
P120-P121	TH617	TA013	TS-3	TL3	2,5 Allen
P122	TH821	TA014-1	TS-4	TL4B	3 Allen
P124-P126	TH825	TA014-1	TS-4	TL4B	3 Allen

95° PCLNR

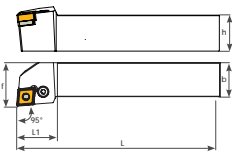

Sipariş Kodu	Ürün Kodu	Ölçüler (mm)						Uç	Fiyat
		L	L1	h	f	b	kg		
P126-1	PCLNR 1616 H09	100	20	16	20	16	0,231	CNMG 09T3	₺879
P127	PCLNR 2020 K09	125	22	20	25	20	0,428	ISO.	₺879
P128	PCLNR 2525 M09	150	22	25	32	25	0,785		₺906
P129	PCLNR 1616 H12	100	30	16	20	16	0,225		₺879
P130	PCLNR 2020 K12	125	30	20	25	20	0,421	CNMG 1204	₺879
P132	PCLNR 2525 M12	150	30	25	32	25	0,766	ISO.	₺906
P134	PCLNR 3232 P12	170	30	32	40	32	1,429		₺1.036

Kod	TH617	TA023	TS3	TL3	2,5 Allen
(P126-1)-(P128)	TH617	TA023	TS3	TL3	2,5 Allen
P129	TH818	TA016-1	TS4	TL4	3 Allen
P130-134	TH821	TA016-1	TS4	TL4	3 Allen

95° PCLNL

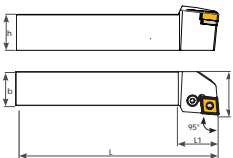
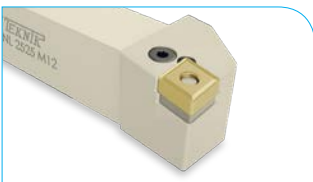

Sipariş Kodu	Ürün Kodu	Ölçüler (mm)						Uç	Fiyat
		L	L1	h	f	b	kg		
P136	PCLNL 1616 H09	100	20	16	20	16	0,231	CNMG 09T3	₺879
P137	PCLNL 2020 K09	125	22	20	25	20	0,428	ISO.	₺879
P138	PCLNL 2525 M09	150	22	25	32	25	0,785		₺906
P139	PCLNL 1616 H12	100	30	16	20	16	0,225		₺879
P140	PCLNL 2020 K12	125	30	20	25	20	0,421	CNMG 1204	₺879
P142	PCLNL 2525 M12	150	30	25	32	25	0,766	ISO.	₺906
P144	PCLNL 3232 P12	170	30	32	40	32	1,429		₺1.036

Kod	TH617	TA023	TS3	TL3	2,5 Allen
P136-P138	TH617	TA023	TS3	TL3	2,5 Allen
P139	TH818	TA016-1	TS4	TL4	3 Allen
P140-144	TH821	TA016-1	TS4	TL4	3 Allen

95° PWLNR 08

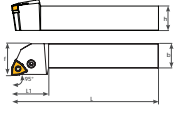

Sipariş Kodu	Ürün Kodu	Ölçüler (mm)						Uç	Fiyat
		L	L1	h	f	b	kg		
P150	PWLNR 2020 K08	125	30	20	25	20	0,430		₺879
P151	PWLNR 2525 M08	150	38	25	32	25	0,773	WNMG 0804	₺906
P152	PWLNR 3232 P08	170	38	32	40	32	1,421	ISO.	₺1.036

95° PWLNL 08

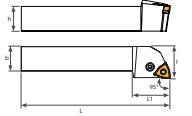

Sipariş Kodu	Ürün Kodu	Ölçüler (mm)						Uç	Fiyat
		L	L1	h	f	b	kg		
P155	PWLNL 2020 K08	125	30	20	25	20	0,430		₺879
P156	PWLNL 2525 M08	150	38	25	32	25	0,773	WNMG 0804	₺906
P157	PWLNL 3232 P08	170	38	32	40	32	1,421	ISO.	₺1.036

95° PWLNR 06

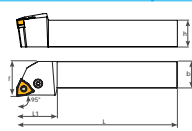

Sipariş Kodu	Ürün Kodu	Ölçüler (mm)						Uç	Fiyat
		L	L1	h	f	b	kg		
P158	PWLNR 1616 H06	100	30	16	20	16	0,223		₺879
P160	PWLNR 2020 K06	125	30	20	25	20	0,429	WNMG 0604	₺879
P161	PWLNR 2525 M06	150	30	25	32	25	0,758	ISO.	₺906

95° PWLNL 06

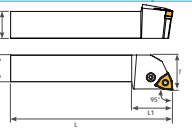
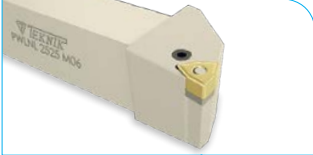

Sipariş Kodu	Ürün Kodu	Ölçüler (mm)						Uç	Fiyat
		L	L1	h	f	b	kg		
P164	PWLNL 1616 H06	100	30	16	20	16	0,223		₺879
P165	PWLNL 2020 K06	125	30	20	25	20	0,429	WNMG 0604	₺879
P166	PWLNL 2525 M06	150	30	25	32	25	0,758	ISO.	₺906

45° PSSNR

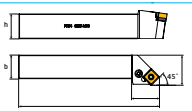

Sipariş Kodu	Ürün Kodu	Ölçüler (mm)						Uç	Fiyat
		L	L1	h	f	b	kg		
P170	PSSNR 1616 H12	100	30	16	20	16	0,218		₺879
P171	PSSNR 2020 K12	125	30	20	25	20	0,416	SNMG 1204	₺879
P172	PSSNR 2525 M12	150	30	25	32	25	0,742	ISO.	₺906

Kod

P170 TH818
 P171-P172 TH821

45° PSSNL

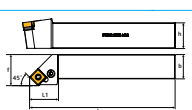



Sipariş Kodu	Ürün Kodu	Ölçüler (mm)						Uç	Fiyat
		L	L1	h	f	b	kg		
P180	PSSNL 1616 H12	100	30	16	20	16	0,218		₺879
P181	PSSNL 2020 K12	125	30	20	25	20	0,416	SNMG 1204	₺879
P182	PSSNL 2525 M12	150	30	25	32	25	0,742	ISO.	₺906





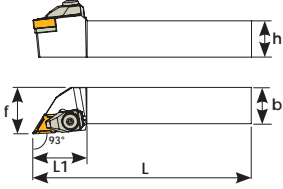

Kod

P180 TH818
 P181-P182 TH821

93° DDJNR









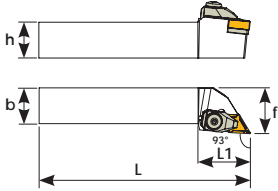
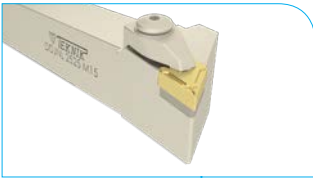

Sipariş Kodu	Ürün Kodu	Ölçüler (mm)						Uç	Fiyat
		L	L1	h	f	b			
D167	DDJNR 2020 K11	125	30	20	25	20	0,421	DNMG 1104	₺879
D168	DDJNR 2525 M11	150	30	25	32	25	0,751	ISO.	₺906
D170	DDJNR 2020 K15	125	35	20	25	20	0,425		₺879
D172	DDJNR 2525 M15	150	35	25	32	25	0,756	DNMG 1506	₺906
D174	DDJNR 3232 P15	170	35	32	40	32	1,345	ISO.	₺1.036

Kod							
D167 - D168	TC046 M5	TA013	TC034 M3x7	BK024	BY041	BSP031	3 Allen
D170 - D174	TC044 M6	TA014-1	TC038 M4x10	BK020	BY040	BSP030	3 Allen

93° DDJNL









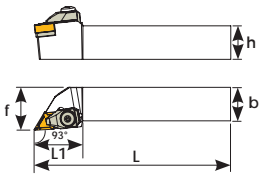
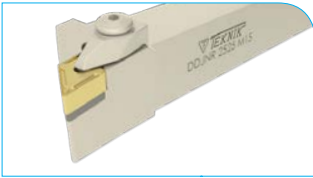

Sipariş Kodu	Ürün Kodu	Ölçüler (mm)						Uç	Fiyat
		L	L1	h	f	b			
D307-1	DDJNL 2020 K11	125	30	20	25	20	0,421	DNMG 1104	₺879
D308	DDJNL 2525 M11	150	30	25	32	25	0,751	ISO.	₺906
D310	DDJNL 2020 K15	125	35	20	25	20	0,425		₺879
D312	DDJNL 2525 M15	150	35	25	32	25	0,756	DNMG 1506	₺906
D314	DDJNL 3232 P15	170	35	32	40	32	1,345	ISO.	₺1.036

Kod							
D307-1 - D308	TC046 M5	TA013	TC034 M3x7	BK024	BY041	BSP031	3 Allen
D310 - D314	TC044 M6	TA014-1	TC038 M4x10	BK020	BY040	BSP030	3 Allen

93° DDJNR









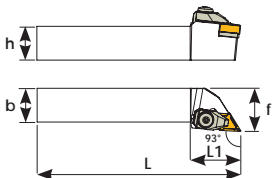
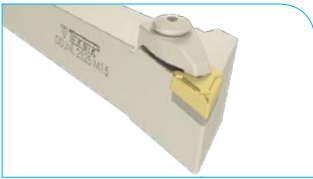

Sipariş Kodu	Ürün Kodu	Ölçüler (mm)						Uç	Fiyat
		L	L1	h	f	b			
D171	DDJNR 2020 K15	125	38	20	25	20	0,426	DNMG 1504	₺879
D169	DDJNR 2525 M15	150	38	25	32	25	0,763	ISO.	₺906

						
TC044 M6	TA014-1	TC038 M4x10	BK020	BY040	BSP030	3 Allen

93° DDJNL



Sipariş Kodu	Ürün Kodu	Ölçüler (mm)						Uç	Fiyat
		L	L1	h	f	b			
D313	DDJNL 2020 K15	125	38	20	25	20	0,426	DNMG 1504	₺879
D309	DDJNL 2525 M15	150	38	25	32	25	0,763	ISO.	₺906

						
TC044 M6	TA014-1	TC038 M4x10	BK020	BY040	BSP030	3 Allen

107,5° DDHNR

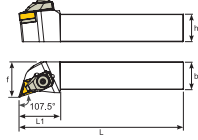

Sipariş Kodu	Ürün Kodu	Ölçüler (mm)						Uç	Fiyat
		L	L1	h	f	b			
D096	DDHNR 2020 K15	125	33	20	25	20	0,428		₺879
D097	DDHNR 2525 M15	150	33	25	32	25	0,753	DNMG 1506	₺906
D098	DDHNR 3232 P15	170	33	32	40	32	1,290	ISO.	₺1.036

TC044 M6	TA014-1	TC038 M4x10	BK020	BY040	BSP030	3 Allen	

107,5° DDHNL

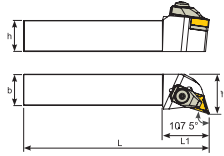

Sipariş Kodu	Ürün Kodu	Ölçüler (mm)						Uç	Fiyat
		L	L1	h	f	b			
D295	DDHNL 2020 K15	125	33	20	25	20	0,428		₺879
D296	DDHNL 2525 M15	150	33	25	32	25	0,753	DNMG 1506	₺906
D297	DDHNL 3232 P15	170	33	32	40	32	1,290	ISO.	₺1.036

TC044 M6	TA014-1	TC038 M4x10	BK020	BY040	BSP030	3 Allen	

62,5° DDNNN

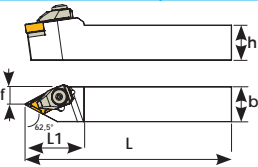

Sipariş Kodu	Ürün Kodu	Ölçüler (mm)						Uç	Fiyat
		L	L1	h	f	b			
D103	DDNNN 2525 M11	150	38	25	25	25	0,700	DNMG 1104	₺906
D104	DDNNN 2020 K15	125	40	20	10	20	0,404		₺879
D106	DDNNN 2525 M15	150	40	25	12,5	25	0,724	DNMG 1506	₺906
D109	DDNNN 3232 P15	170	40	32	16	32	1,290	ISO.	₺1.036

Kod								
D103	TC046 M5	TA030	TC075 M4x11	BK024	BY041	BSP031	3 Allen	
D104-D109	TC044 M6	TA014-1	TC038 M4x10	BK020	BY040	BSP030	3 Allen	

95° DCLNR

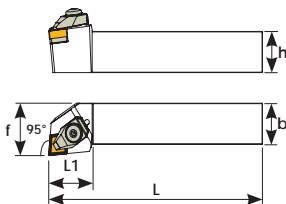

Sipariş Kodu	Ürün Kodu	Ölçüler (mm)						Uç	Fiyat
		L	L1	h	f	b			
D160	DCLNR 2020 K12	125	30	20	25	20	0,441	CNMG 1204	₺879
D162	DCLNR 2525 M12	150	30	25	32	25	0,785	ISO.	₺906
D164	DCLNR 3232 P12	170	30	32	40	32	1,379		₺1.036
D162-1	DCLNR 2525 M16	150	36	25	32	25	0,432	CNMG 1606	₺1.036
D165	DCLNR 3232 P16	170	36	32	40	32	1,407	ISO.	₺1.115
D163	DCLNR 2525 M19	150	40	25	32	25	0,820	CNMG 1906	₺1.115
D166	DCLNR 3232 P19	170	40	32	40	32	1,430	ISO.	₺1.296
D166-1	DCLNR 4040 S19	250	40	40	40	40	3,195		₺1.863

Kod								
D160 - D164	TC044 M6	TA016-1	TC038 M4x10	BK020	BY040	BSP030	3 Allen	
D162-1 - D165		TA022	TC095 M5x11,8	BK018				
D163 - D166-1	TC047 M8	TA017	TC039 M6x12	BK025	BY044	BSP032	5 Allen	

95° DCLNL

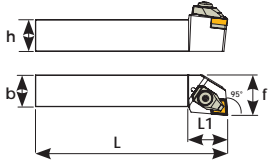

Sipariş Kodu	Ürün Kodu	Ölçüler (mm)						Uç	Fiyat
		L	L1	h	f	b	kg		
D301	DCLNL 2020 K12	125	30	20	25	20	0,441	CNMG 1204	₺879
D302	DCLNL 2525 M12	150	30	25	32	25	0,785	ISO.	₺906
D305	DCLNL 3232 P12	170	30	32	40	32	1,379		₺1.036
D303	DCLNL 2525 M16	150	36	25	32	25	0,432	CNMG 1606	₺1.036
D306	DCLNL 3232 P16	170	36	32	40	32	1,407	ISO.	₺1.115
D304	DCLNL 2525 M19	150	40	25	32	25	0,820	CNMG 1906	₺1.115
D307	DCLNL 3232 P19	170	40	32	40	32	1,430	ISO.	₺1.296
D307-2	DCLNL 4040 S19	250	40	40	40	40	3,195		₺1.863

Kod								
D301 - D305	TC044 M6	TA016-1	TC038 M4x10	BK020	BY040	BSP030	3 Allen	
D303 - D306	TC044 M6	TA022	TC095 M5x11,8	BK018	BY040	BSP030	3 Allen	
D304 - D307-2	TC047 M8	TA017	TC039 M6x12	BK025	BY044	BSP032	5 Allen	

50° DCMNN

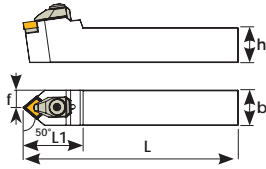

Sipariş Kodu	Ürün Kodu	Ölçüler (mm)						Uç	Fiyat
		L	L1	h	f	b	kg		
D214-1	DCMNN 2020 K12	125	35	20	10	20	0,445	CNMG 1204 ISO.	₺879
D215	DCMNN 2525 M12	150	35	25	12,5	25	0,778		₺906

Kod								
D214-1	TC044 M6	TA016-1	TC038 M4x10	BK020	BY040	BSP030	3 Allen	

40° DCXNN

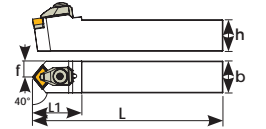
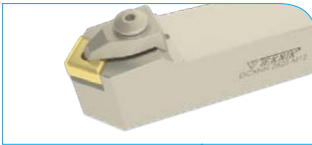

Sipariş Kodu	Ürün Kodu	Ölçüler (mm)						Uç	Fiyat
		L	L1	h	f	b	kg		
D216	DCXNN 2525 M12	150	35	25	12,5	25	0,756	CNMG 1204 ISO.	₺906

Kod								
D216	TC044 M6	TA016-1	TC038 M4x10	BK020	BY040	BSP030	3 Allen	

75° DCKNR

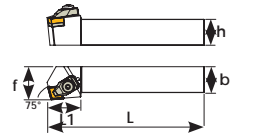
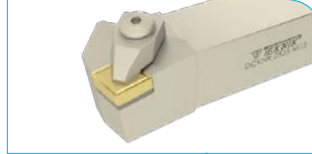

Sipariş Kodu	Ürün Kodu	Ölçüler (mm)						Uç	Fiyat
		L	L1	h	f	b	kg		
D116-1	DCKNR 2525 M12	150	30	25	32	25	0,440	CNMG 1204 ISO	₺906
D162-3	DCKNR 2525 M16	150	40	25	32	25	0,576	CNMG 1606 ISO.	₺1.036

Kod								
D116-1	TC044 M6	TA016-1	TC038 M4x10	BK020	BY040	BSP030	3 Allen	
D162-3	TC044 M6	TA022	TC095 M5x11,8	BK018	BY040	BSP030	3 Allen	

45° DCSNR

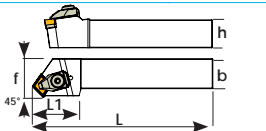

Sipariş Kodu	Ürün Kodu	Ölçüler (mm)						Uç	Fiyat
		L	L1	h	f	b	kg		
D218	DCSNR 2525 M12	150	35	25	32	25	0,774	CNMG 1204 ISO.	₺906

Kod								
D218	TC044 M6	TA016-1	TC038 M4x10	BK020	BY040	BSP030	3 Allen	

45° DSSNR

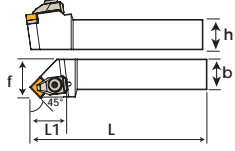
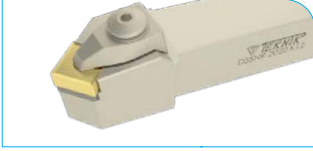

Sipariş Kodu	Ürün Kodu	Ölçüler (mm)						Uç	Fiyat
		L	L1	h	f	b	kg		
D210	DSSNR 2020 K12	125	35	20	25	20	0,440	SNMG 1204	₺879
D212	DSSNR 2525 M12	150	35	25	32	25	0,576	ISO.	₺906
D205	DSSNR 3232 P12	170	36	32	32	40	1,280		₺1.036
D206	DSSNR 3232 P19	170	46	32	32	40	1,383	SNMG 1906	₺1.448
D207	DSSNR 4040 S19	250	46	40	40	50	3,123	ISO.	₺1.943
D208	DSSNR 4040 S25	250	60	40	40	50	3,012	SNMG 2508	₺2.123

Kod							
D210-D205	TC044 M6	TA050	TC038 M4x10	BK020	BY040	BSP030	3 Allen
D206-D207	TC047 M8	TA051	TC039 M6x12	BK025	BY044	BSP032	
D208	TC047 M8	TA053	TC041 M8x20	BK027	BY044	BSP032	5 Allen

95° DWLNR

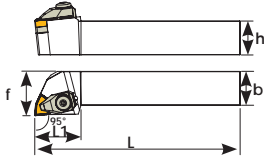

Sipariş Kodu	Ürün Kodu	Ölçüler (mm)						Uç	Fiyat
		L	L1	h	f	b	kg		
D181	DWLNR 1616 H06	100	26	16	20	16	0,229		₺879
D177	DWLNR 2020 K06	125	26	20	25	20	0,436	WNMG 0604	₺879
D179	DWLNR 2525 M06	150	26	25	32	25	0,772	ISO.	₺906
D176	DWLNR 2020 K08	125	32	20	25	20	0,442		₺879
D178	DWLNR 2525 M08	150	32	25	32	25	0,793	WNMG 0804	₺906
D180	DWLNR 3232 P08	170	32	32	40	32	1,377	ISO.	₺1.036

Kod							
D181 - D179	TC046 M5	TA021	TC034 M3x7	BK024	BY041	BSP031	3 Allen
D176 - D180	TC044 M6	TA020-1	TC038 M5x12	BK020	BY040	BSP030	3 Allen

95° DWLNL

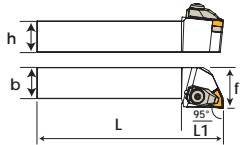

Sipariş Kodu	Ürün Kodu	Ölçüler (mm)						Uç	Fiyat
		L	L1	h	f	b	kg		
D328	DWLNL 1616 H06	100	26	16	20	16	0,229	WNMG 0604	₺879
D329	DWLNL 2020 K06	125	26	20	25	20	0,436	ISO.	₺879
D319	DWLNL 2525 M06	150	26	25	32	25	0,772		₺906
D316	DWLNL 2020 K08	125	32	20	25	20	0,442	WNMG 0804	₺879
D318	DWLNL 2525 M08	150	32	25	32	25	0,793	ISO.	₺906
D320	DWLNL 3232 P08	170	32	32	40	32	1,377		₺1.036

Kod							
D328 - D319	TC046 M5	TA021	TC034 M3x7	BK024	BY041	BSP031	3 Allen
D316 - D320	TC044 M6	TA020-1	TC038 M5x12	BK020	BY040	BSP030	3 Allen

95° MWLNR

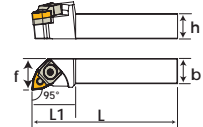

Sipariş Kodu	Ürün Kodu	Ölçüler (mm)						Uç	Fiyat
		L	L1	h	f	b	kg		
D182	MWLNR 2020 K08	125	32	20	25	20	0,435		₺879
D184	MWLNR 2525 M08	150	32	25	32	25	0,761	WNMG 0804	₺906
D185	MWLNR 3232 P08	170	32	32	40	32	1,349	ISO.	₺1.036

Kod							
TC044 M6	TA020	BSP021	BK026	BY040	BSP030		3 Allen

95° MWLNL

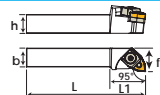
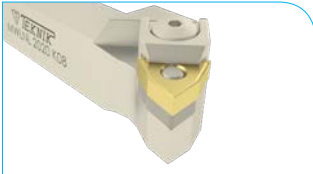

Sipariş Kodu	Ürün Kodu	Ölçüler (mm)						Uç	Fiyat
		L	L1	h	f	b	kg		
D322	MWLNL 2020 K08	125	32	20	25	20	0,435		₺879
D324	MWLNL 2525 M08	150	32	25	32	25	0,761	WNMG 0804	₺906
D326	MWLNL 3232 P08	170	32	32	40	32	1,349	ISO.	₺1.036

Kod							
TC044 M6	TA020	BSP021	BK026	BY040	BSP030		3 Allen

95 MWMNN

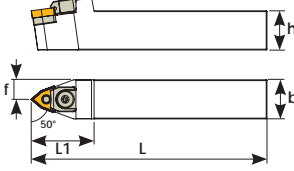

Sipariş Kodu	Ürün Kodu	Ölçüler (mm)						Uç	Fiyat
		L	L1	h	f	b			
D114	MWMNN 2020 K08	125	40	20	10	20	0,432	WNMG 0804	₺879
D116	MWMNN 2525 M08	150	40	25	12.5	25	0,724	ISO.	₺906

TC044 M6	TA020	BSP021	BK026	BY040	BSP030	3 Allen	

93° MTJNR

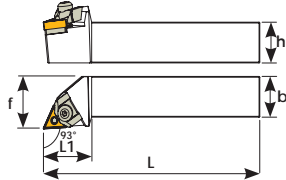
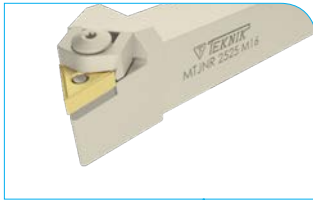

Sipariş Kodu	Ürün Kodu	Ölçüler (mm)						Uç	Fiyat
		L	L1	h	f	b			
D194	MTJNR 2020 K16	125	35	20	25	20	0,429	TNMG 1604	₺879
D196	MTJNR 2525 M16	150	35	25	32	25	0,760	ISO.	₺906
D198	MTJNR 3232 P16	170	35	32	40	32	1,360		₺1.036
D200	MTJNR 2020 K22	125	37	20	25	20	0,429	TNMG 2204	₺959
D202	MTJNR 2525 M22	150	40	25	32	25	0,775	ISO.	₺985
D204	MTJNR 3232 P22	170	40	32	40	32	1,348		₺1.089

Kod								
D194 - D198	TC046 M5	TA019	BSP020	BK022	BY043	BSP031	3 Allen	
D200 - D204	TC044 M6	TA045	BSP021	BK023	BY040	BSP030	3 Allen	

93° MTJNL

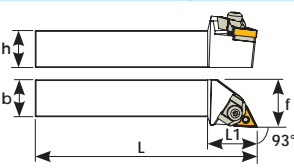
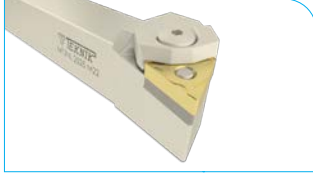

Sipariş Kodu	Ürün Kodu	Ölçüler (mm)						Uç	Fiyat
		L	L1	h	f	b			
D332	MTJNL 2020 K16	125	35	20	25	20	0,429		₺879
D334	MTJNL 2525 M16	150	35	25	32	25	0,760	TNMG 1604	₺906
D336	MTJNL 3232 P16	170	35	32	40	32	1,360	ISO.	₺1.036
D338	MTJNL 2020 K22	125	37	20	25	20	0,429	TNMG 2204	₺959
D340	MTJNL 2525 M22	150	40	25	32	25	0,775	ISO.	₺985
D342	MTJNL 3232 P22	170	40	32	40	32	1,348		₺1.089

Kod								
D332 - D336	TC046 M5	TA019	BSP020	BK022	BY043	BSP031	3 Allen	
D338 - D342	TC044 M6	TA045	BSP021	BK023	BY040	BSP030	3 Allen	

60° MTENN

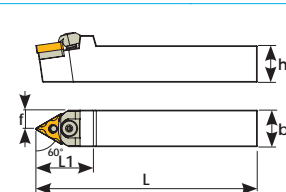

Sipariş Kodu	Ürün Kodu	Ölçüler (mm)						Uç	Fiyat
		L	L1	h	f	b			
D108	MTENN 2020 K16	125	35	20	10	20	0,408	TNMG 1604	₺879
D110	MTENN 2525 M16	150	35	25	12.5	25	0,724	ISO.	₺906
D112	MTENN 2525 M22	150	40	25	12.5	25	0,734	TNMG 2204	₺985
D113	MTENN 3232 P22	170	40	32	16	32	1,311	ISO.	₺1.089

Kod								
D108 - D110	TC046 M5	TA019	BSP020	BK022	BY043	BSP031	3 Allen	
D112 - D113	TC044 M6	TA045	BSP021	BK023	BY040	BSP030	3 Allen	

93° DVJNR

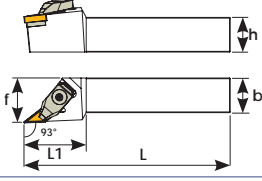

Sipariş Kodu	Ürün Kodu	Ölçüler (mm)						Uç	Fiyat
		L	L1	h	f	b	kg		
D105-1	DVJNR 2020 K16	125	40	20	27	20	0,428	VNMG 1604	₺879
D105	DVJNR 2525 M16	150	40	25	32	25	0,427	ISO.	₺906

TC046 M5	TA033	TC074 M4x10	BK021	BY043	BSP031	3 Allen		

93° DVJNL

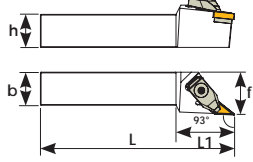

Sipariş Kodu	Ürün Kodu	Ölçüler (mm)						Uç	Fiyat
		L	L1	h	f	b	kg		
D343	DVJNL 2020 K16	125	40	20	27	20	0,428	VNMG 1604	₺879
D344	DVJNL 2525 M16	150	40	25	32	25	0,427	ISO.	₺906

TC046 M5	TA033	TC074 M4x10	BK021	BY043	BSP031	3 Allen		

72,5° DVVNN

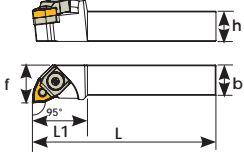

Sipariş Kodu	Ürün Kodu	Ölçüler (mm)						Uç	Fiyat
		L	L1	h	f	b	kg		
D105-2	DVVNN 2525 M16	150	45	25	12,5	25	0,690	VNMG 1604	₺906

TC046 M5	TA033	TC074 M4x10	BK021	BY043	BSP031	3 Allen		

93° CKJNR

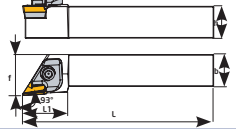

Sipariş Kodu	Ürün Kodu	Ölçüler (mm)						Uç	Fiyat
		L	L1	h	f	b	kg		
RD018	CKJNR 2020 K16	125	32	20	27	20	0,434	KNUX 1604	₺841
RD014	CKJNR 2525 M16	150	35	25	30	25	0,753		₺866
RD013	CKJNR 3232 P16	170	35	32	40	32	1,311		₺1.000

TC044 M6	TA046	TC036 M3x10	BK028	BY042	BSP030	3 Allen		

93° CKJNL

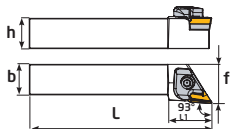



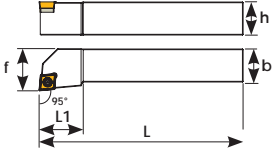

Sipariş Kodu	Ürün Kodu	Ölçüler (mm)						Uç	Fiyat
		L	L1	h	f	b	kg		
RD038	CKJNL 2020 K16	125	32	20	27	20	0,434	KNUX 1604	₺841
RD034	CKJNL 2525 M16	150	35	25	30	25	0,753		₺866
RD032	CKJNL 3232 P16	170	35	32	40	32	1,311		₺1.000

TC044 M6	TA046	TC036 M3x10	BK028	BY042	BSP030	3 Allen		

95° SCLCR





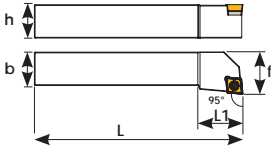

Sipariş Kodu	Ürün Kodu	Ölçüler (mm)						Uç	Fiyat
		L	L1	h	f	b			
D398	SCLCR 1010 J06	110	10	10	12	10	0,105	CCMT 0602 ISO.	₺570
D400	SCLCR 1212 J09	110	16	12	16	12	0,140		₺570
D401	SCLCR 1616 H09	100	20	16	20	16	0,215	CCMT 09T3	₺619
D402	SCLCR 2020 K09	125	25	20	25	20	0,425	ISO.	₺704
D403	SCLCR 2525 M09	150	25	25	32	25	0,772		₺725
D418	SCLCR 2020 K12	125	25	20	25	20	0,421	CCMT 1204	₺779
D403-1	SCLCR 2525 M12	150	25	25	32	25	0,768	ISO.	₺829

Kod				
D398	TC060 M2,5x5,5	--	--	T8
D400	TC067 M3,5x8,5	--	--	T15
D401-D403	TC068 M3,5x11	TA015	TC048 M5	T15
D418-D403-1	TC075 M4x11	TA015-1	TC049-1 M6	T15

95° SCLCL





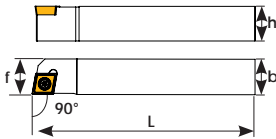

Sipariş Kodu	Ürün Kodu	Ölçüler (mm)						Uç	Fiyat
		L	L1	h	f	b			
D404	SCLCL 1010 J06	110	10	10	12	10	0,105	CCMT 0602	₺570
D405	SCLCL 1212 J09	110	16	12	16	12	0,140	ISO.	₺570
D406	SCLCL 1616 H09	100	20	16	20	16	0,215	CCMT 09T3	₺619
D407	SCLCL 2020 K09	125	25	20	25	20	0,425	ISO.	₺704
D408	SCLCL 2525 M09	150	25	25	32	25	0,772		₺725
D420	SCLCL 2020 K12	125	25	20	25	20	0,421	CCMT 1204	₺779
D421	SCLCL 2525 M12	150	25	25	32	25	0,768	ISO.	₺829

Kod				
D404	TC060 M2,5x5,5	--	--	T8
D405	TC067 M3,5x8,5	--	--	T15
D406-D408	TC068 M3,5x11	TA015	TC048 M5	T15
D420-D421	TC075 M4x11	TA015-1	TC049-1 M6	T15

90° SCACR-F





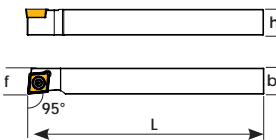
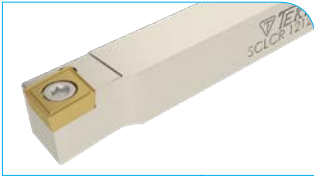

Sipariş Kodu	Ürün Kodu	Ölçüler (mm)				Uç	Fiyat	
		L	h	f	b			
D411	SCACR 1010 J06-F	110	10	10	10	0,104	CCMT 0602 ISO	₺570
D412	SCACR 1212 J09-F	110	12	12	12	0,143		₺570
D414	SCACR 1616 H09-F	100	16	16	16	0,221	CCMT 09T3	₺619
D416	SCACR 2020 K09-F	125	20	20	20	0,420	ISO.	₺704

Kod				
D411	TC060 M2,5x5,5	--	--	T8
D412	TC067 M3,5x11	--	--	T15
D414-D416	TC068 M3,5x11	TA015	TC048 M5	T15

95° SCLCR-F



Sipariş Kodu	Ürün Kodu	Ölçüler (mm)				Uç	Fiyat	
		L	h	f	b			
D422	SCLCR 1010 J06-F	110	10	10	10	0,106	CCMT 0602	₺570
D424	SCLCR 1212 J06-F	110	12	12	12	0,147	ISO.	₺570
D426	SCLCR 1212 J09-F	110	12	12	12	0,144	CCMT 09T3	₺570
D428	SCLCR 1616 H09-F	100	16	16	16	0,224	ISO.	₺619
D430	SCLCR 2020 K09-F	125	20	20	20	0,426		₺704

Kod				
D422-D424	TC060 M2,5x5,5	--	--	T8
D426-D430	TC068 M3,5x11	--	--	T15
D428-D430	TC068 M3,5x11	TA015	TC048 M5	T15

93° SDJCR

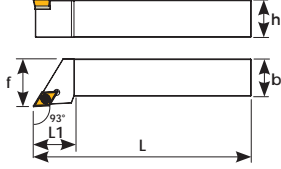

Sipariş Kodu	Ürün Kodu	Ölçüler (mm)						Uç	Fiyat																														
		L	L1	h	f	b	kg																																
D220	SDJCR 1010 J07	110	15	10	12	10	0,097	DCMT 0702 ISO	₺570																														
D222	SDJCR 1212 J11	110	20	12	16	12	0,132		₺570																														
D224	SDJCR 1616 H11	100	25	16	20	16	0,204	DCMT 11T3	₺619																														
D226	SDJCR 2020 K11	125	25	20	25	20	0,404	ISO.	₺704																														
D228	SDJCR 2525 M11	150	30	25	32	25	0,735		₺725																														
<p>Kod</p> <table border="0"> <tr> <td>D220</td> <td>TC060 M2,5x5,5</td> <td>---</td> <td>---</td> <td>---</td> <td>---</td> <td>---</td> <td>---</td> <td>T8</td> <td></td> </tr> <tr> <td>D222</td> <td>TC067 M3,5x8,5</td> <td>---</td> <td>---</td> <td>---</td> <td>---</td> <td>---</td> <td>---</td> <td>---</td> <td>T15</td> </tr> <tr> <td>D224-D228</td> <td>TC068 M3,5x11</td> <td>TA030</td> <td>---</td> <td>---</td> <td>---</td> <td>---</td> <td>TC048 M5</td> <td>---</td> <td></td> </tr> </table>										D220	TC060 M2,5x5,5	---	---	---	---	---	---	T8		D222	TC067 M3,5x8,5	---	---	---	---	---	---	---	T15	D224-D228	TC068 M3,5x11	TA030	---	---	---	---	TC048 M5	---	
D220	TC060 M2,5x5,5	---	---	---	---	---	---	T8																															
D222	TC067 M3,5x8,5	---	---	---	---	---	---	---	T15																														
D224-D228	TC068 M3,5x11	TA030	---	---	---	---	TC048 M5	---																															

93° SDJCL

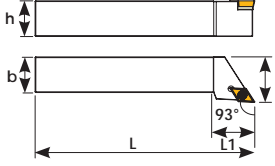
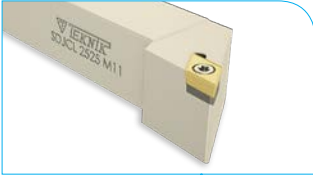

Sipariş Kodu	Ürün Kodu	Ölçüler (mm)						Uç	Fiyat																														
		L	L1	h	f	b	kg																																
D360	SDJCL 1010 J07	110	15	10	12	10	0,097	DCMT 0702 ISO	₺570																														
D362	SDJCL 1212 J11	110	20	12	16	12	0,132		₺570																														
D364	SDJCL 1616 H11	100	25	16	20	16	0,204	DCMT 11T3	₺619																														
D366	SDJCL 2020 K11	125	25	20	25	20	0,404	ISO.	₺704																														
D368	SDJCL 2525 M11	150	30	25	32	25	0,735		₺725																														
<p>Kod</p> <table border="0"> <tr> <td>D360</td> <td>TC060 M2,5x5,5</td> <td>---</td> <td>---</td> <td>---</td> <td>---</td> <td>---</td> <td>---</td> <td>T8</td> <td></td> </tr> <tr> <td>D362</td> <td>TC067 M3,5x8,5</td> <td>---</td> <td>---</td> <td>---</td> <td>---</td> <td>---</td> <td>---</td> <td>---</td> <td>T15</td> </tr> <tr> <td>D366-D368</td> <td>TC068 M3,5x11</td> <td>TA030</td> <td>---</td> <td>---</td> <td>---</td> <td>---</td> <td>TC048 M5</td> <td>---</td> <td></td> </tr> </table>										D360	TC060 M2,5x5,5	---	---	---	---	---	---	T8		D362	TC067 M3,5x8,5	---	---	---	---	---	---	---	T15	D366-D368	TC068 M3,5x11	TA030	---	---	---	---	TC048 M5	---	
D360	TC060 M2,5x5,5	---	---	---	---	---	---	T8																															
D362	TC067 M3,5x8,5	---	---	---	---	---	---	---	T15																														
D366-D368	TC068 M3,5x11	TA030	---	---	---	---	TC048 M5	---																															

62,5° SDNCN

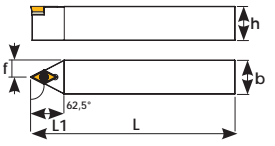

Sipariş Kodu	Ürün Kodu	Ölçüler (mm)						Uç	Fiyat																														
		L	L1	h	f	b	kg																																
D117	SDNCN 1010 J07	110	15	10	5	10	0,096	DCMT 0702 ISO	₺570																														
D118	SDNCN 1212 J11	110	25	12	6	12	0,131		₺570																														
D120	SDNCN 1616 H11	100	25	16	8	16	0,196	DCMT 11T3	₺619																														
D122	SDNCN 2020 K11	125	25	20	10	20	0,390	ISO.	₺704																														
D124	SDNCN 2525 M11	150	25	25	12,5	25	0,705		₺725																														
<p>Kod</p> <table border="0"> <tr> <td>D117</td> <td>TC060 M2,5x5,5</td> <td>---</td> <td>---</td> <td>---</td> <td>---</td> <td>---</td> <td>---</td> <td>T8</td> <td></td> </tr> <tr> <td>D118</td> <td>TC067 M3,5x8,5</td> <td>---</td> <td>---</td> <td>---</td> <td>---</td> <td>---</td> <td>---</td> <td>---</td> <td>T15</td> </tr> <tr> <td>D120-D124</td> <td>TC068 M3,5x11</td> <td>TA030</td> <td>---</td> <td>---</td> <td>---</td> <td>---</td> <td>TC048 M5</td> <td>---</td> <td></td> </tr> </table>										D117	TC060 M2,5x5,5	---	---	---	---	---	---	T8		D118	TC067 M3,5x8,5	---	---	---	---	---	---	---	T15	D120-D124	TC068 M3,5x11	TA030	---	---	---	---	TC048 M5	---	
D117	TC060 M2,5x5,5	---	---	---	---	---	---	T8																															
D118	TC067 M3,5x8,5	---	---	---	---	---	---	---	T15																														
D120-D124	TC068 M3,5x11	TA030	---	---	---	---	TC048 M5	---																															

90° SDACR-F

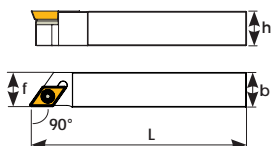

Sipariş Kodu	Ürün Kodu	Ölçüler (mm)					Uç	Fiyat																											
		L	L1	h	f	kg																													
D434	SDACR 1010 J07-F	110	10	10	10	0,970	DCMT 0702	₺570																											
D436	SDACR 1212 J07-F	110	12	12	12	0,135	ISO.	₺570																											
D438	SDACR 1616 H07-F	100	16	16	16	0,207		₺619																											
D440	SDACR 1212 J11-F	110	12	12	12	0,135		₺570																											
D442	SDACR 1616 H11-F	100	16	16	16	0,200	DCMT 11T3	₺619																											
D444	SDACR 2020 K11-F	125	20	20	20	0,397	ISO.	₺704																											
<p>Kod</p> <table border="0"> <tr> <td>D434-D438</td> <td>TC060 M2,5x5,5</td> <td>---</td> <td>---</td> <td>---</td> <td>---</td> <td>---</td> <td>---</td> <td>T8</td> </tr> <tr> <td>D440</td> <td>TC067 M3,5x8,5</td> <td>---</td> <td>---</td> <td>---</td> <td>---</td> <td>---</td> <td>---</td> <td>---</td> </tr> <tr> <td>D442-D444</td> <td>TC067 M3,5x8,5</td> <td>TA030</td> <td>---</td> <td>---</td> <td>---</td> <td>---</td> <td>TC048 M5</td> <td>T15</td> </tr> </table>									D434-D438	TC060 M2,5x5,5	---	---	---	---	---	---	T8	D440	TC067 M3,5x8,5	---	---	---	---	---	---	---	D442-D444	TC067 M3,5x8,5	TA030	---	---	---	---	TC048 M5	T15
D434-D438	TC060 M2,5x5,5	---	---	---	---	---	---	T8																											
D440	TC067 M3,5x8,5	---	---	---	---	---	---	---																											
D442-D444	TC067 M3,5x8,5	TA030	---	---	---	---	TC048 M5	T15																											

93° SDJCR-F

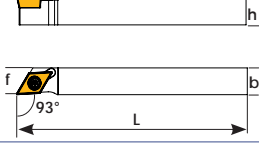

Sipariş Kodu	Ürün Kodu	Ölçüler (mm)					Uç	Fiyat
		L	h	f	b			
D452	SDJCR 1010 J07-F	110	10	10	10	0,103	DCMT 0702	₺570
D454	SDJCR 1212 J07-F	110	12	12	12	0,131	ISO.	₺570
D456	SDJCR 1616 H07-F	100	16	16	16	0,192		₺619
D457	SDJCR 1212 J11-F	110	12	12	12	0,134	DCMT 11T3 ISO.	₺570
D458	SDJCR 1616 H11-F	100	16	16	16	0,181		₺619

Kod

D452-D456
D457-D458

TC060 M2,5x5,5
TC067 M3,5x8,5



93° SDJCL-F

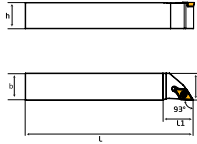

Sipariş Kodu	Ürün Kodu	Ölçüler (mm)						Uç	Fiyat
		L	L1	h	f	b			
D154	SDJCL 1212 K07-F	125	15	12	12	12	0,135	DCMT 0702	₺570
D155	SDJCL 1616 H07-F	100	18	16	16	16	0,152	ISO.	₺619
D156	SDJCL 1212 J11-F	110	20	12	12	12	0,134	DCMT 11T3	₺570
D157	SDJCL 1616 H11-F	100	25	16	16	16	0,180		₺619

Kod

D154-D155
D156-D157

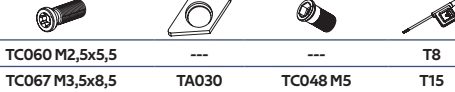

107,5° SDHCR

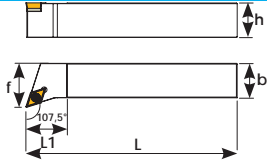

Sipariş Kodu	Ürün Kodu	Ölçüler (mm)						Uç	Fiyat
		L	L1	h	f	b			
D250	SDHCR 2020 K11	125	25	20	25	20	0,411	DCMT 11T3	₺704
D252	SDHCR 2525 M11	150	25	25	32	25	0,738	ISO.	₺725

Kod

TC068 M3,5x11



107,5° SDHCL

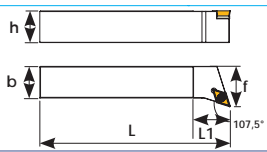
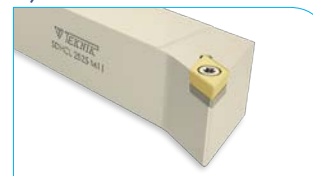

Sipariş Kodu	Ürün Kodu	Ölçüler (mm)						Uç	Fiyat
		L	L1	h	f	b			
D350	SDHCL 2020 K11	125	25	20	25	20	0,411	DCMT 11T3	₺704
D352	SDHCL 2525 M11	150	25	25	32	25	0,738	ISO.	₺725

Kod

TC068 M3,5x11



93° SVJBR

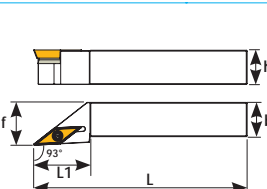

Sipariş Kodu	Ürün Kodu	Ölçüler (mm)						Uç	Fiyat
		L	L1	h	f	b			
D230	SVJBR 1010 J11	110	21	10	12	10	0,097	VBMT 1103	₺570
D232	SVJBR 1212 J11	110	21	12	16	12	0,141	ISO.	₺570
D234	SVJBR 1616 H11	100	25	16	20	16	0,192		₺619
D235	SVJBR 1616 H16	100	33	16	20	16	0,192	VBMT 1604	₺619
D236	SVJBR 2020 K16	125	33	20	25	20	0,382	ISO.	₺704
D238	SVJBR 2525 M16	150	40	25	32	25	0,688		₺725
D238-1	SVJBR 3232 P16	170	40	32	40	32	1,370		₺854

Kod

D230-D234
D235-D238-1



93° SVJBL

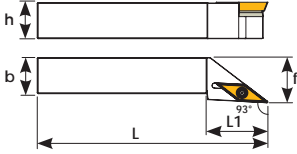
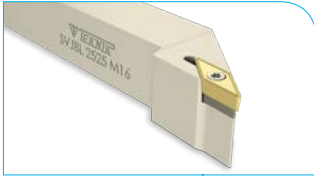

Sipariş Kodu	Ürün Kodu	Ölçüler (mm)						Uç	Fiyat
		L	L1	h	f	b			
D370	SVJBL 1010 J11	110	21	10	12	10	0,097	VBMT 1103	₺570
D372	SVJBL 1212 J11	110	21	12	16	12	0,141	ISO.	₺570
D373	SVJBL 1616 H11	100	25	16	20	16	0,192		₺619
D374	SVJBL 1616 H16	100	33	16	20	16	0,192	VBMT 1604	₺619
D380	SVJBL 2020 K16	125	33	20	25	20	0,382	ISO.	₺704
D382	SVJBL 2525 M16	150	40	25	32	25	0,688		₺725
D382-1	SVJBL 3232 P16	170	40	32	40	32	1,370		₺854
Kod									
D370-D373		TC061 M2,5x6,5	---	---	T8				
D374-D238-1		TC068 M3,5x11	TA034	TC048 M5		T15			

72,5° SVVBN

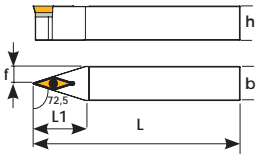

Sipariş Kodu	Ürün Kodu	Ölçüler (mm)						Uç	Fiyat
		L	L1	h	f	b			
D131	SVVBN 1212 J11	110	25	12	6	12	0,129	VBMT 1103 ISO	₺570
D132	SVVBN 1616 H16	100	33	16	8	16	0,184	VBMT 1604	₺619
D138	SVVBN 2020 K16	125	35	20	10	20	0,370	ISO.	₺704
D140	SVVBN 2525 M16	150	40	25	12,5	25	0,668		₺725
D141	SVVBN 3232-P16	170	40	32	40	32	1,386		₺854
Kod									
D131		TC061 M2,5x6,5	---	---	T8				
D132-D141		TC068 M3,5x11	TA034	TC048 M5		T15			

107,5° SVHBR

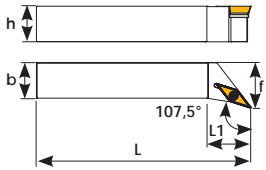

Sipariş Kodu	Ürün Kodu	Ölçüler (mm)						Uç	Fiyat
		L	L1	h	f	b			
D354-1	SVHBR 2020 K16	125	30	20	25	20	0,387	VBMT 1604	₺704
D356-1	SVHBR 2525 M16	150	30	25	32	25	0,712	ISO.	₺725
Kod									
D354-1		TC068 M3,5x11	TA034	TC048 M5		T15			

107,5° SVHBL

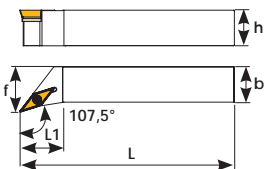

Sipariş Kodu	Ürün Kodu	Ölçüler (mm)						Uç	Fiyat
		L	L1	h	f	b			
D355	SVHBL 2020 K16	125	30	20	25	20	0,387	VBMT 1604	₺704
D356-2	SVHBL 2525 M16	150	30	25	32	25	0,712	ISO.	₺725
Kod									
D355		TC068 M3,5x11	TA034	TC048 M5		T15			

93° SVJBR-F

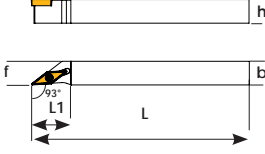

Sipariş Kodu	Ürün Kodu	Ölçüler (mm)						Uç	Fiyat
		L	L1	h	f	b			
D128	SVJBR 1010 J11-F	110	22	10	10	10	0,098		₺570
D129	SVJBR 1212 J11-F	110	22	12	12	12	0,132	VBMT 1103	₺570
D130	SVJBR 1616 H11-F	100	25	16	16	16	0,204	ISO.	₺619
Kod									
		TC061 M2,5x6,5		TA034		TC048 M5		T8	

93° SVJBL-F

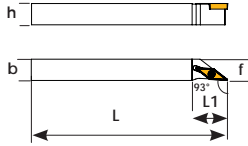
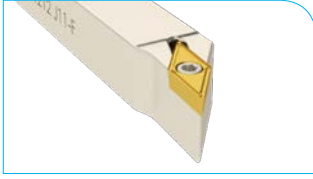

Sipariş Kodu	Ürün Kodu	Ölçüler (mm)						Uç	Fiyat
		L	L1	h	f	b			
D395	SVJBL 1010 J11-F	110	22	10	10	10	0,098		₺570
D396	SVJBL 1212 J11-F	110	22	12	12	12	0,132	VBMT 1103	₺570
D397	SVJBL 1616 H11-F	100	25	16	16	16	0,204	ISO.	₺619
Kod									
		TC061 M2,5x6,5		TA034		TC048 M5		T8	

93° SVJCR

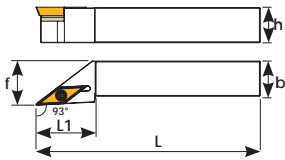

Sipariş Kodu	Ürün Kodu	Ölçüler (mm)						Uç	Fiyat
		L	L1	h	f	b			
D239	SVJCR 1010 J11	110	21	10	12	10	0,086		₺570
D240	SVJCR 1212 J11	110	21	12	16	12	0,135	VCMT 1103	₺570
D241	SVJCR 1616 H11	100	25	16	20	16	0,204	ISO.	₺619
D242	SVJCR 2020 K11	125	33	20	25	20	0,378		₺704
D243	SVJCR 2525 M11	150	40	25	32	25	0,738		₺725
D244	SVJCR 1616 H16	100	33	16	20	16	0,195	VCMT 1604	₺619
D246	SVJCR 2020 K16	125	33	20	25	20	0,385	ISO.	₺704
D248	SVJCR 2525 M16	150	40	25	32	25	0,683		₺725
D249	SVJCR 3232 P16	170	50	32	40	32	1,284		₺854
Kod									
D239-D243		TC061 M2,5x6,5		---	---	T8			
D244-D249		TC068 M3,5x11		TA034	TC048 M5	T15			

93° SVJCL

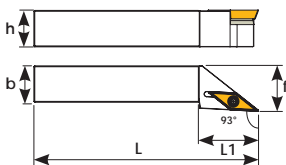

Sipariş Kodu	Ürün Kodu	Ölçüler (mm)						Uç	Fiyat
		L	L1	h	f	b			
D383	SVJCL 1010 J11	110	21	10	12	10	0,086		₺570
D384	SVJCL 1212 J11	110	21	12	16	12	0,135	VCMT 1103	₺570
D385	SVJCL 1616 H11	100	25	16	20	16	0,204	ISO.	₺619
D386	SVJCL 2020 K11	125	33	20	25	20	0,378		₺704
D387	SVJCL 2525 M11	150	40	25	32	25	0,738		₺725
D388	SVJCL 1616 H16	100	33	16	20	16	0,195	VCMT 1604	₺619
D390	SVJCL 2020 K16	125	33	20	25	20	0,385	ISO.	₺704
D392	SVJCL 2525 M16	150	40	25	32	25	0,683		₺725
D393	SVJCL 3232 P16	170	50	32	40	32	1,284		₺854
Kod									
D383-D387		TC061 M2,5x7		---	---	T8			
D388-D923		TC068 M3,5x11		TA034	TC048 M5	T15			

90° SVJCR -F

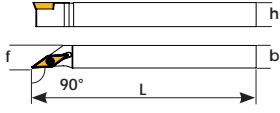

Sipariş Kodu	Ürün Kodu	Ölçüler (mm)					Uç	Fiyat
		L	h	f	b			
D460	SVJCR 1212 J11-F	110	12	12	12	0,134	VCMT 1103	₺570
D462	SVJCR 1616 H11-F	100	16	16	16	0,202	ISO.	₺619
		TC061 M2,5x6,5		T8				

72,5° SVVCN

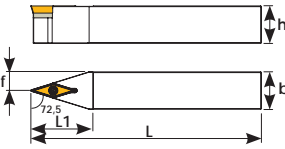
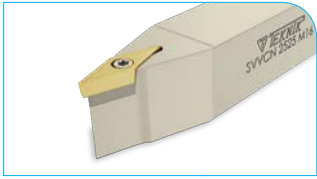

Sipariş Kodu	Ürün Kodu	Ölçüler (mm)						Uç	Fiyat
		L	L1	h	f	b			
D142	SVVCN 1212 J11	110	22	12	6	12	0,127	VCMT 1103 ISO	₺570
D144	SVVCN 1616 H16	100	35	16	8	16	0,187	VCMT 1604	₺619
D150	SVVCN 2020 K16	125	35	20	10	20	0,373	ISO.	₺704
D152	SVVCN 2525 M16	150	40	25	12,5	25	0,675		₺725
Kod									
D142	TC061 M2,5x6,5	---	---	T8					
D144-D152	TC068 M3,5x11	TA034	TC048 M5	T15					

107,5° SVHCR

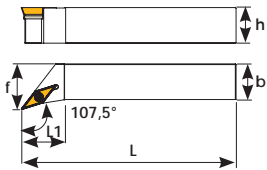

Sipariş Kodu	Ürün Kodu	Ölçüler (mm)					Uç	Fiyat	
		L	L1	h	f	b			
D254	SVHCR 2020 K16	125	30	20	25	20	0,384	VCMT 1604	₺704
D256	SVHCR 2525 M16	150	30	25	32	25	0,707	ISO.	₺725
		TC068 M3,5x11	TA034	TC048 M5	T15				

SVHCL

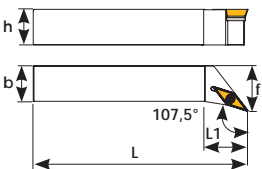

Sipariş Kodu	Ürün Kodu	Ölçüler (mm)					Uç	Fiyat	
		L	L1	h	f	b			
D354	SVHCL 2020 K16	125	30	20	25	20	0,384	VCMT 1604	₺704
D356	SVHCL 2525 M16	150	30	25	32	25	0,707	ISO.	₺725
		TC068 M3,5x11	TA034	TC048 M5	T15				

30° SRGCR

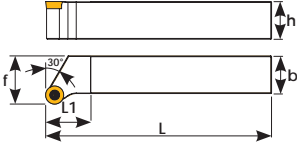

Sipariş Kodu	Ürün Kodu	Ölçüler (mm)						Uç	Fiyat
		L	L1	h	f	b			
D280	SRGCR 2020 K08	125	25	20	25	20	0,411	RCMT 0803	₺704
D282	SRGCR 2525 M08	150	30	25	32	25	0,710	ISO.	₺725
D284	SRGCR 2020 K10	125	25	20	25	20	0,410	RCMT 10T3	₺704
D286	SRGCR 2525 M10	150	30	25	32	25	0,720	ISO.	₺725
D288	SRGCR 2020 K12	125	25	20	25	20	0,422	RCMT 1204	₺704
D290	SRGCR 2525 M12	150	30	25	32	25	0,744	ISO.	₺725

Kod

D280-D282

TC065 M3x7

T8

D284-D290

TC067 M3,5x8,5

T15

30° SRGCL

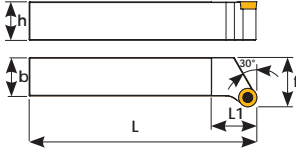

Sipariş Kodu	Ürün Kodu	Ölçüler (mm)						Uç	Fiyat
		L	L1	h	f	b			
D293	SRGCL 2020 K08	125	25	20	25	20	0,411	RCMT 0803	₺704
D294	SRGCL 2525 M08	150	30	25	32	25	0,710	ISO.	₺725
D283	SRGCL 2020 K10	125	25	20	25	20	0,410	RCMT 10T3	₺704
D292	SRGCL 2525 M10	150	30	25	32	25	0,720	ISO.	₺725
D281	SRGCL 2020 K12	125	25	20	25	20	0,422	RCMT 1204 ISO.	₺704
D291	SRGCL 2525 M12	150	30	25	32	25	0,744	ISO.	₺725

Kod

D293-D294

TC065 M3x7

T8

D283-D291

TC067 M3,5x8,5

T15

SRDCN

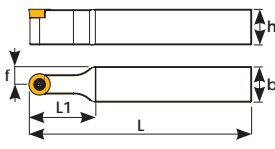

Sipariş Kodu	Ürün Kodu	Ölçüler (mm)						Uç	Fiyat
		L	L1	h	f	b			
D270	SRDCN 2020 K08	125	37	20	10	20	0,358	RCMT 0803	₺704
D271	SRDCN 2525 M08	150	37	25	12.5	25	0,653	ISO.	₺725
D272	SRDCN 2020 K10	125	35	20	10	20	0,370	RCMT 10T3	₺704
D274	SRDCN 2525 M10	150	35	25	12.5	25	0,670	ISO.	₺725
D276	SRDCN 2020 K12	125	33	20	10	20	0,372	RCMT 1204	₺704
D278	SRDCN 2525 M12	150	38	25	12.5	25	0,668	ISO.	₺725
D273	SRDCN 2525 M16	150	35	25	12.5	25	0,701	RCMT 1606 ISO.	₺725

Kod

D270-D271

TC065 M3x7

T8

D272-D278

TC067 M3,5x8,5



T15

D273

TC083 M5x12

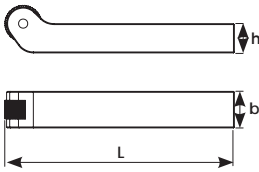
TIRTİL Kater



Sipariş Kodu	Ürün Kodu			Ölçüler (mm)			Fiyat	
				L	h	b		
P100	16-20 CNC TIRTİL	20x10x6	BSP041 6-23	125	16	20	0,351	₺779
P102	20-20 CNC TIRTİL	20x10x6	BSP041 6-18	125	20	20	0,427	₺779
P104	25-25 CNC TIRTİL	20x10x6	BSP040 6-23	150	25	25	0,600	₺829

93° PDUNR IC Soğutmalı

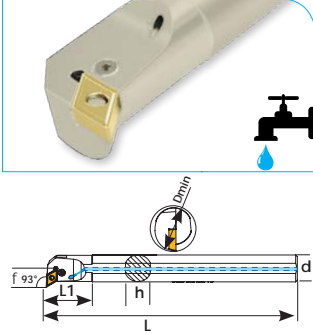

Sipariş Kodu	Ürün Kodu	Ölçüler (mm)							Uç	Fiyat
		Dmin	d	L	L1	f	h			
AP300	A25S PDUNR 15	32	25	250	50	17	23	0,900		₺1.479
AP302	A32T PDUNR 15	40	32	300	55	22	30	1,770	DNMG 1506	₺1.771
AP304	A40T PDUNR 15	50	40	300	55	27	38	1,790	ISO.	₺2.324
<p>Kod </p> <p>AP300 TH6134 --- --- TL4A 2,5 Allen </p> <p>AP302 - AP304 TH821 TA014-1 TS-4 TL4B 3 Allen </p>										

93° PDUNR

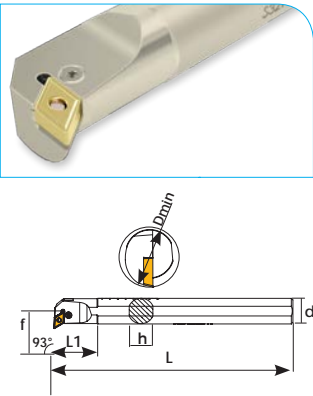

Sipariş Kodu	Ürün Kodu	Ölçüler (mm)							Uç	Fiyat
		Dmin	d	L	L1	f	h			
P300	S25S PDUNR 15	32	25	250	50	17	23	0,930		₺1.284
P302	S32T PDUNR 15	40	32	300	55	22	30	1,805	DNMG 1506	₺1.544
P304	S40T PDUNR 15	50	40	300	55	27	38	2,790	ISO.	₺2.031
<p>Kod </p> <p>P300 TH6134 --- --- TL4A TL4A </p> <p>P302 - P304 TH821 TA014-1 TS-4 TL4B 3 Allen </p>										

93° PDUNL IC Soğutmalı

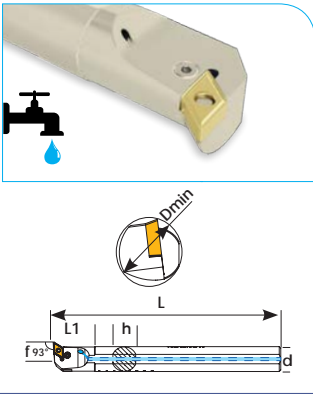

Sipariş Kodu	Ürün Kodu	Ölçüler (mm)							Uç	Fiyat
		Dmin	d	L	L1	f	h			
AP309	A20R PDUNL 11	25	20	200	40	13	18	0,500	DNMG 1104	₺1.235
AP310	A25S PDUNL 15	32	25	250	50	17	23	0,900		₺1.479
AP312	A32T PDUNL 15	40	32	300	55	22	30	1,770	DNMG 1506	₺1.771
AP314	A40T PDUNL 15	50	40	300	55	27	38	1,790	ISO.	₺2.324
<p>Kod </p> <p>AP309 TH512 --- --- TL3B 2 Allen </p> <p>AP310 TH6134 --- --- TL4A 2,5 Allen </p> <p>AP312 - AP314 TH821 TA014-1 TS-4 TL4B 3 Allen </p>										

93° PDUNL

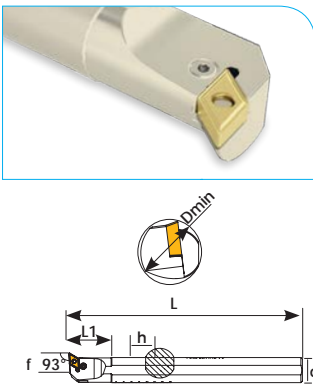

Sipariş Kodu	Ürün Kodu	Ölçüler (mm)							Uç	Fiyat
		Dmin	d	L	L1	f	h			
P310	S25S PDUNL 15	32	25	250	50	17	23	0,930		₺1.284
P312	S32T PDUNL 15	40	32	300	55	22	30	1,805	DNMG 1506	₺1.544
P314	S40T PDUNL 15	50	40	300	55	27	38	2,790	ISO.	₺2.031
<p>Kod </p> <p>P310 TH6134 --- --- TL4A TL4A </p> <p>P312 - P314 TH821 TA014-1 TS-4 TL4B 3 Allen </p>										

95° PCLNR IC Soğutmalı

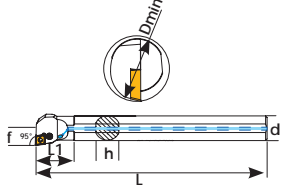

Sipariş Kodu	Ürün Kodu	Ölçüler (mm)							Uç	Fiyat																		
		Dmin	d	L	L1	f	h																					
AP337	A20R PCLNL 09	25	20	200	40	13	18	0,435	CNMG 09T3	₺1.235																		
AP338	A20R PCLNR 12	24	20	200	50	13	18	0,520		₺1.235																		
AP340	A25S PCLNR 12	32	25	250	50	17	23	0,921	CNMG 1204	₺1.479																		
AP342	A32T PCLNR 12	40	32	300	50	22	30	1,809	ISO.	₺1.771																		
AP344	A40T PCLNR 12	50	40	300	55	27	38	1,820		₺2.324																		
<p>Code</p> <table border="1"> <tr> <td>AP337</td> <td>THB617</td> <td>TA023</td> <td>TS3</td> <td>TL3</td> <td>2,5 Allen</td> </tr> <tr> <td>AP338-AP340</td> <td>TH6134</td> <td>---</td> <td>---</td> <td>TL4A</td> <td>2,5 Allen</td> </tr> <tr> <td>AP342-AP344</td> <td>TH821</td> <td>TA016-1</td> <td>TS-4</td> <td>TL4</td> <td>3 Allen</td> </tr> </table>											AP337	THB617	TA023	TS3	TL3	2,5 Allen	AP338-AP340	TH6134	---	---	TL4A	2,5 Allen	AP342-AP344	TH821	TA016-1	TS-4	TL4	3 Allen
AP337	THB617	TA023	TS3	TL3	2,5 Allen																							
AP338-AP340	TH6134	---	---	TL4A	2,5 Allen																							
AP342-AP344	TH821	TA016-1	TS-4	TL4	3 Allen																							

95° PCLNR

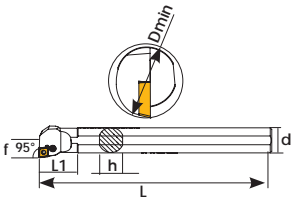

Sipariş Kodu	Ürün Kodu	Ölçüler (mm)							Uç	Fiyat												
		Dmin	d	L	L1	f	h															
P338	S20R PCLNR 12	24	20	200	50	13	18	0,540		₺1.073												
P340	S25S PCLNR 12	32	25	250	50	17	23	0,978	CNMG 1204	₺1.284												
P342	S32T PCLNR 12	40	32	300	50	22	30	1,815	ISO.	₺1.544												
P344	S40T PCLNR 12	50	40	300	55	27	38	1,825		₺2.031												
<p>Kod</p> <table border="1"> <tr> <td>P338 - P340</td> <td>TH6134</td> <td>---</td> <td>---</td> <td>TL4A</td> <td>2,5 Allen</td> </tr> <tr> <td>P342 - P344</td> <td>TH821</td> <td>TA016-1</td> <td>TS-4</td> <td>TL4</td> <td>3 Allen</td> </tr> </table>											P338 - P340	TH6134	---	---	TL4A	2,5 Allen	P342 - P344	TH821	TA016-1	TS-4	TL4	3 Allen
P338 - P340	TH6134	---	---	TL4A	2,5 Allen																	
P342 - P344	TH821	TA016-1	TS-4	TL4	3 Allen																	

95° PCLNL IC Soğutmalı

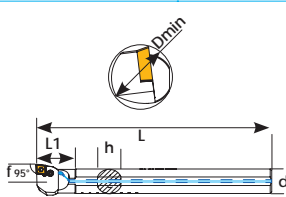
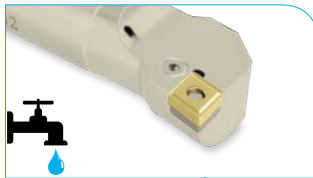

Sipariş Kodu	Ürün Kodu	Ölçüler (mm)							Uç	Fiyat																		
		Dmin	d	L	L1	f	h																					
AP347	A20R PCLNR 09	26	20	200	40	13	18	0,435	CNMG 09T3	₺1.235																		
AP348	A20R PCLNL 12	24	20	200	50	13	18	0,520		₺1.235																		
AP350	A25S PCLNL 12	32	25	250	50	17	23	0,921	CNMG 1204	₺1.479																		
AP352	A32T PCLNL 12	40	32	300	50	22	30	1,809	ISO.	₺1.771																		
AP354	A40T PCLNL 12	50	40	300	55	27	38	1,820		₺2.324																		
<p>Kod</p> <table border="1"> <tr> <td>AP347</td> <td>TH617</td> <td>TA023</td> <td>TS3</td> <td>TL3</td> <td>2,5 Allen</td> </tr> <tr> <td>AP348-AP350</td> <td>TH6134</td> <td>---</td> <td>---</td> <td>TL4A</td> <td>2,5 Allen</td> </tr> <tr> <td>AP352-AP354</td> <td>TH821</td> <td>TA016-1</td> <td>TS-4</td> <td>TL4</td> <td>3 Allen</td> </tr> </table>											AP347	TH617	TA023	TS3	TL3	2,5 Allen	AP348-AP350	TH6134	---	---	TL4A	2,5 Allen	AP352-AP354	TH821	TA016-1	TS-4	TL4	3 Allen
AP347	TH617	TA023	TS3	TL3	2,5 Allen																							
AP348-AP350	TH6134	---	---	TL4A	2,5 Allen																							
AP352-AP354	TH821	TA016-1	TS-4	TL4	3 Allen																							



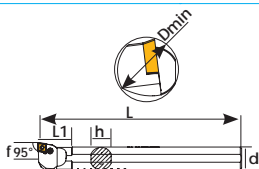
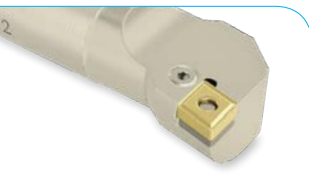



95° PCLNL

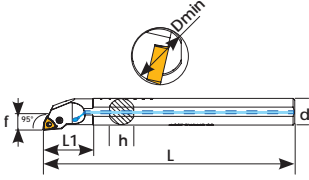

Sipariş Kodu	Ürün Kodu	Ölçüler (mm)							Uç	Fiyat												
		Dmin	d	L	L1	f	h															
P348	S20R PCLNL 12	24	20	200	50	13	18	0,540		₺1.073												
P350	S25S PCLNL 12	32	25	250	50	17	23	0,978	CNMG 1204	₺1.284												
P352	S32T PCLNL 12	40	32	300	50	22	30	1,815	ISO.	₺1.544												
P354	S40T PCLNL 12	50	40	300	55	27	38	1,825		₺2.031												
<p>Kod</p> <table border="1"> <tr> <td>P348 - P350</td> <td>TH6134</td> <td>---</td> <td>---</td> <td>TL4A</td> <td>2,5 Allen</td> </tr> <tr> <td>P352 - P354</td> <td>TH821</td> <td>TA016-1</td> <td>TS-4</td> <td>TL4</td> <td>3 Allen</td> </tr> </table>											P348 - P350	TH6134	---	---	TL4A	2,5 Allen	P352 - P354	TH821	TA016-1	TS-4	TL4	3 Allen
P348 - P350	TH6134	---	---	TL4A	2,5 Allen																	
P352 - P354	TH821	TA016-1	TS-4	TL4	3 Allen																	







95° PWLNR 08 IC Soğutmalı

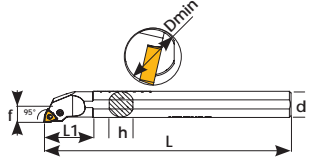

Sipariş Kodu	Ürün Kodu	Ölçüler (mm)							Uç	Fiyat
		Dmin	d	L	L1	f	h			
AP360	A25S PWLNR 08	32	25	250	50	17	23	0,911		₺1.479
AP362	A32T PWLNR 08	40	32	300	60	22	30	1,764	WNMG 0804	₺1.771
AP364	A40T PWLNR 08	50	40	300	60	27	38	2,800	ISO.	₺2.324
<p>Kod      </p> <p>AP360 TH6134 --- --- TL4A 2,5 Allen</p> <p>AP362 - P364 TH821 TA020-1 TS-4 TL4 3 Allen</p>										







95° PWLNR 08

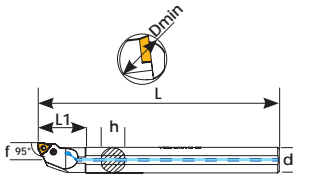

Sipariş Kodu	Ürün Kodu	Ölçüler (mm)							Uç	Fiyat
		Dmin	d	L	L1	f	h			
P360	S25S PWLNR 08	32	25	250	50	17	23	0,911		₺1.284
P362	S32T PWLNR 08	40	32	300	60	22	30	1,764	WNMG 0804	₺1.544
P364	S40T PWLNR 08	50	40	300	60	27	38	2,450	ISO.	₺2.031
<p>Kod      </p> <p>P360 TH6134 --- --- TL4A 2,5 Allen</p> <p>P362 - P364 TH821 TA020-1 TS-4 TL4 3 Allen</p>										







95° PWLNL 08 IC Soğutmalı

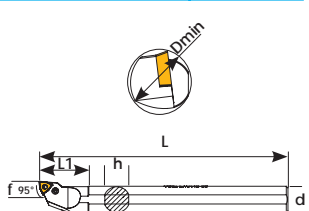

Sipariş Kodu	Ürün Kodu	Ölçüler (mm)							Uç	Fiyat
		Dmin	d	L	L1	f	h			
AP370	A25S PWLNL 08	32	25	250	50	17	23	0,911		₺1.479
AP372	A32T PWLNL 08	40	32	300	60	22	30	1,764	WNMG 0804	₺1.771
AP374	A40T PWLNL 08	50	40	300	60	27	38	2,800	ISO.	₺2.324
<p>Kod      </p> <p>AP370 TH6134 --- --- TL4A 2,5 Allen</p> <p>AP372 - P374 TH821 TA020-1 TS-4 TL4 3 Allen</p>										

95° PWLNL 08



Sipariş Kodu	Ürün Kodu	Ölçüler (mm)							Uç	Fiyat
		Dmin	d	L	L1	f	h			
P370	S25S PWLNL 08	32	25	250	50	17	23	0,911		₺1.284
P372	S32T PWLNL 08	40	32	300	60	22	30	1,764	WNMG 0804	₺1.544
P374	S40T PWLNL 08	50	40	300	60	27	38	2,450	ISO.	₺2.031
<p>Kod      </p> <p>P370 TH6134 --- --- TL4A 2,5 Allen</p> <p>P372 - P374 TH821 TA020-1 TS-4 TL4 3 Allen</p>										

95° PVLNR 06 IC
Soğutmalı

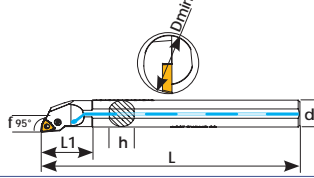

Sipariş Kodu	Ürün Kodu	Ölçüler (mm)							Uç	Fiyat
		Dmin	d	L	L1	f	h			
AP380	A16R PVLNR 06	20	16	200	40	11	15	0,326	WNMG 0604	₺1.235
AP382	A20R PVLNR 06	25	20	200	40	13	18	0,471	ISO.	₺1.235

95° PVLNR 06

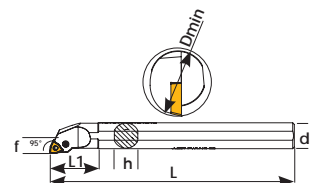

Sipariş Kodu	Ürün Kodu	Ölçüler (mm)							Uç	Fiyat
		Dmin	d	L	L1	f	h			
P380	S16R PVLNR 06	20	16	200	40	11	15	0,316	WNMG 0604	₺1.073
P382	S20R PVLNR 06	25	20	200	40	13	18	0,502	ISO.	₺1.073

95° PVLNL 06 IC
Soğutmalı

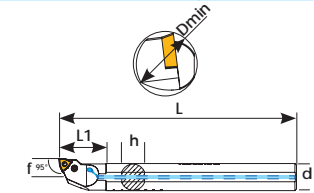
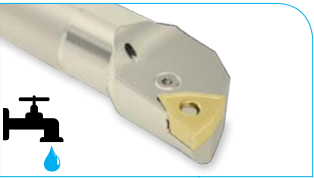

Sipariş Kodu	Ürün Kodu	Ölçüler (mm)							Uç	Fiyat
		Dmin	d	L	L1	f	h			
AP388	A16R PVLNL 06	20	16	200	40	11	15	0,326	WNMG 0604	₺1.235
AP390	A20R PVLNL 06	25	20	200	40	13	18	0,471	ISO.	₺1.235

95° PVLNL 06

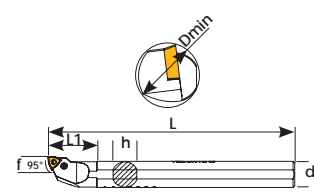
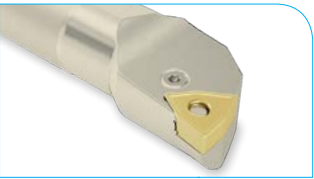

Sipariş Kodu	Ürün Kodu	Ölçüler (mm)							Uç	Fiyat
		Dmin	d	L	L1	f	h			
P388	S16R PVLNL 06	20	16	200	40	11	15	0,316	WNMG 0604	₺1.073
P390	S20R PVLNL 06	25	20	200	40	13	18	0,502	ISO.	₺1.073

93° DDUNR

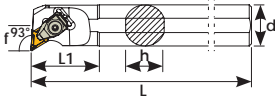
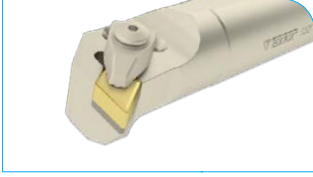

Sipariş Kodu	Ürün Kodu	Ölçüler (mm)							Uç	Fiyat
		Dmin	d	L	L1	f	h	kg		
K408	S20R DDUNR 11	30	20	200	50	13	18	0,508	DNMG 1104	₺1.073
K409	S25S DDUNR 11	32	25	250	50	17	23	0,956	ISO.	₺1.284
K410	S25S DDUNR 15	32	25	250	50	17	23	0,950		₺1.284
K412	S32T DDUNR 15	40	32	300	55	22	30	1,835		₺1.544
K414	S40T DDUNR 15	50	40	300	60	27	38	2,848		₺2.031
K415	S40U DDUNR 15	50	40	350	60	27	38	3,336	DNMG 1506	₺2.194
K416	S50U DDUNR 15	63	50	350	65	35	47	5,153	ISO.	₺2.503
K417	S50X DDUNR 15	63	50	550	65	35	47	8,716		₺3.169
K417-1	S60X DDUNR 15	73	60	600	65	37,5	57	13,66		₺4.631
K411	S25S DDUNR 15	32	25	250	50	17	23	0,958	DNMG 1504	₺1.284
K413	S32T DDUNR 15	40	32	300	55	22	30	1,830	ISO.	₺1.544

Kod

K408 - K409 TC046 M5 TA013 TC034 M3x7 BK024 BY041 BSP031 3 Allen

K410 - K413 TC044 M6 TA014-1 TC038 M4x10 BK020 BY040 BSP030 3 Allen

93° DDUNL

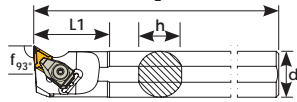

Sipariş Kodu	Ürün Kodu	Ölçüler (mm)							Uç	Fiyat
		Dmin	d	L	L1	f	h	kg		
K487	S20R DDUNL 11	30	20	200	50	13	18	0,508	DNMG 1104	₺1.073
K488	S25S DDUNL 11	32	25	250	50	17	23	0,956	ISO.	₺1.284
K490	S25S DDUNL 15	32	25	250	50	17	23	0,950		₺1.284
K492	S32T DDUNL 15	40	32	300	55	22	30	1,835	DNMG 1506	₺1.544
K494	S40T DDUNL 15	50	40	300	60	27	38	2,848	ISO.	₺2.031
K495	S40U DDUNL 15	50	40	350	60	27	38	3,336		₺2.194
K496	S50U DDUNL 15	63	50	350	65	35	47	5,153		₺2.503

Kod

K487 - K488 TC046 M5 TA013 TC034 M3x7 BK024 BY041 BSP031 3 Allen

K490 - K496 TC044 M6 TA014-1 TC038 M4x10 BK020 BY040 BSP030 3 Allen

107,5° DDQNR

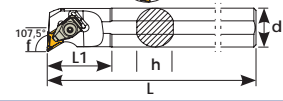
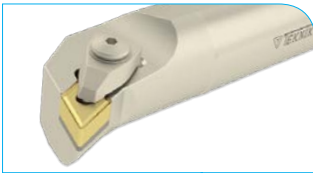

Sipariş Kodu	Ürün Kodu	Ölçüler (mm)							Uç	Fiyat
		Dmin	d	L	L1	f	h	kg		
K476	S25S DDQNR 15	32	25	250	50	17	23	0,935		₺1.284
K477	S32T DDQNR 15	40	32	300	60	22	30	1,805	DNMG 1506	₺1.544
K478	S40T DDQNR 15	50	40	300	60	27	38	2,786	ISO.	₺2.031
K479	S50U DDQNR 15	63	50	350	65	35	47	5,166		₺2.503

Kod

TC044 M6 TA014-1 TC038 M4x10 BK020 BY040 BSP030 3 Allen

107,5° DDQNL

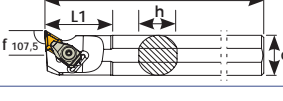

Sipariş Kodu	Ürün Kodu	Ölçüler (mm)							Uç	Fiyat
		Dmin	d	L	L1	f	h	kg		
K533	S25S DDQNL 15	32	25	250	50	17	23	0,935		₺1.284
K534	S32T DDQNL 15	40	32	300	60	22	30	1,805	DNMG 1506	₺1.544
K535	S40T DDQNL 15	50	40	300	60	27	38	2,786	ISO.	₺2.031
K536	S50U DDQNL 15	63	50	350	65	35	47	5,166		₺2.503

Kod

TC044 M6 TA014-1 TC038 M4x10 BK020 BY040 BSP030 3 Allen

93° MDUNR

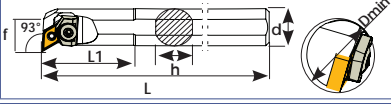

Sipariş Kodu	Ürün Kodu	Ölçüler (mm)							Uç	Fiyat
		Dmin	d	L	L1	f	h	kg		
K408-1	S20R MDUNR 11	25	20	200	50	13	18	0,508	DNMG 1104 ISO.	₺1.073

62,5° DDWNR

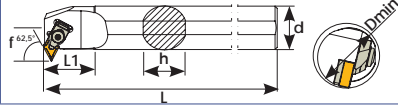
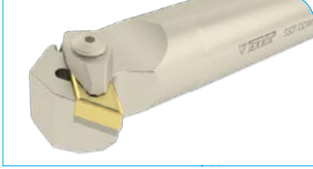

Sipariş Kodu	Ürün Kodu	Ölçüler (mm)							Uç	Fiyat
		Dmin	d	L	L1	f	h	kg		
K464	S32T DDWNR 15	40	32	300	55	24	30	1,859		₺1.544
K466	S40T DDWNR 15	50	40	300	50	30	38	2,918	DNMG 1506	₺2.031
K468	S50U DDWNR 15	63	50	350	60	35	47	5,298	ISO.	₺2.503

60° MTENR

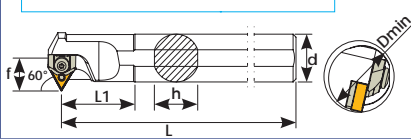
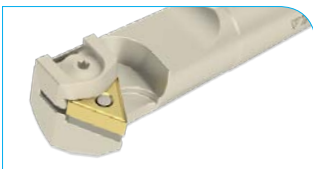

Sipariş Kodu	Ürün Kodu	Ölçüler (mm)							Uç	Fiyat
		Dmin	d	L	L1	f	h	kg		
K456	S25S MTENR 16	32	25	250	55	17	23	0,960		₺1.284
K458	S32T MTENR 16	40	32	300	60	22	30	1,842	TNMG 1604	₺1.544
K460	S40T MTENR 16	50	40	300	60	27	38	2,802	ISO.	₺2.031
K462	S50U MTENR 16	63	50	350	70	35	47	5,125		₺2.503

93° MTUNR

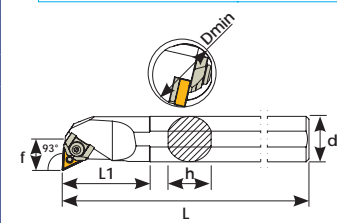
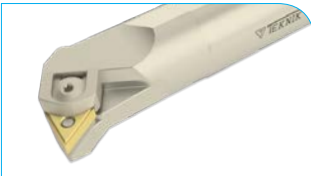

Sipariş Kodu	Ürün Kodu	Ölçüler (mm)							Uç	Fiyat																									
		Dmin	d	L	L1	f	h	kg																											
K441	S20R MTUNR 16	25	20	200	50	13	18	0,513		₺1.073																									
K442	S25S MTUNR 16	32	25	250	50	17	23	0,952	TNMG 1604	₺1.284																									
K444	S32T MTUNR 16	40	32	300	60	22	30	1,835	ISO.	₺1.544																									
K446	S40T MTUNR 16	50	40	300	60	27	38	2,852		₺2.031																									
K448	S50U MTUNR 16	63	50	350	65	35	47	5,150		₺2.503																									
K450	S32T MTUNR 22	40	32	300	60	22	30	1,836	TNMG 2204	₺1.544																									
K452	S40T MTUNR 22	50	40	300	60	27	38	2,814	ISO.	₺2.031																									
K454	S50U MTUNR 22	63	50	350	65	35	47	5,145		₺2.503																									
<p>Kod</p> <table border="0"> <tr> <td>K411</td> <td>TC043 M5</td> <td>---</td> <td>BSP019</td> <td>BK017-1</td> <td>BY041</td> <td>BSP031</td> <td>3 Allen</td> <td rowspan="3"></td> </tr> <tr> <td>K442 - K448</td> <td>TC046 M5</td> <td>TA019</td> <td>BSP020</td> <td>BK022</td> <td>BY043</td> <td>BSP031</td> <td>3 Allen</td> </tr> <tr> <td>K450 - K454</td> <td>TC044 M6</td> <td>TA045</td> <td>BSP021</td> <td>BK023</td> <td>BY040</td> <td>BSP030</td> <td>3 Allen</td> </tr> </table>											K411	TC043 M5	---	BSP019	BK017-1	BY041	BSP031	3 Allen		K442 - K448	TC046 M5	TA019	BSP020	BK022	BY043	BSP031	3 Allen	K450 - K454	TC044 M6	TA045	BSP021	BK023	BY040	BSP030	3 Allen
K411	TC043 M5	---	BSP019	BK017-1	BY041	BSP031	3 Allen																												
K442 - K448	TC046 M5	TA019	BSP020	BK022	BY043	BSP031	3 Allen																												
K450 - K454	TC044 M6	TA045	BSP021	BK023	BY040	BSP030	3 Allen																												

93° MTUNL

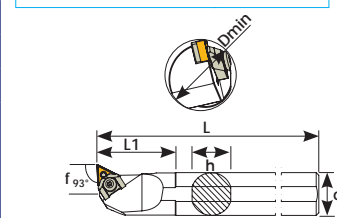

Sipariş Kodu	Ürün Kodu	Ölçüler (mm)							Uç	Fiyat																									
		Dmin	d	L	L1	f	h	kg																											
K519	S20R MTUNL 16	25	20	200	30	13	18	0,513		₺1.073																									
K520	S25S MTUNL 16	32	25	250	50	17	23	0,952	TNMG 1604	₺1.284																									
K522	S32T MTUNL 16	40	32	300	60	22	30	1,835	ISO.	₺1.544																									
K524	S40T MTUNL 16	50	40	300	60	27	38	2,852		₺2.031																									
K526	S50U MTUNL 16	63	50	350	65	35	47	5,150		₺2.503																									
K528	S32T MTUNL 22	40	32	300	60	22	30	1,836	TNMG 2204	₺1.544																									
K530	S40T MTUNL 22	50	40	300	60	27	38	2,814	ISO.	₺2.031																									
K532	S50U MTUNL 22	63	50	350	65	35	47	5,145		₺2.503																									
<p>Kod</p> <table border="0"> <tr> <td>K519</td> <td>TC043 M5</td> <td>---</td> <td>BSP019</td> <td>BK017-1</td> <td>BY041</td> <td>BSP031</td> <td>3 Allen</td> <td rowspan="3"></td> </tr> <tr> <td>K520 - K526</td> <td>TC046 M5</td> <td>TA019</td> <td>BSP020</td> <td>BK022</td> <td>BY043</td> <td>BSP031</td> <td>3 Allen</td> </tr> <tr> <td>K528 - K532</td> <td>TC044 M6</td> <td>TA045</td> <td>BSP021</td> <td>BK023</td> <td>BY040</td> <td>BSP030</td> <td>3 Allen</td> </tr> </table>											K519	TC043 M5	---	BSP019	BK017-1	BY041	BSP031	3 Allen		K520 - K526	TC046 M5	TA019	BSP020	BK022	BY043	BSP031	3 Allen	K528 - K532	TC044 M6	TA045	BSP021	BK023	BY040	BSP030	3 Allen
K519	TC043 M5	---	BSP019	BK017-1	BY041	BSP031	3 Allen																												
K520 - K526	TC046 M5	TA019	BSP020	BK022	BY043	BSP031	3 Allen																												
K528 - K532	TC044 M6	TA045	BSP021	BK023	BY040	BSP030	3 Allen																												

107,5° MTQNR

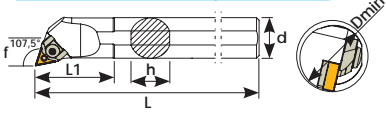

Sipariş Kodu	Ürün Kodu	Ölçüler (mm)							Uç	Fiyat
		Dmin	d	L	L1	f	h			
K365	S25S MTQNR 16	32	25	250	50	17	23	0,942		₺1.284
K366	S32T MTQNR 16	40	32	300	60	22	30	1,821	TNMG 1604	₺1.544
K367	S40T MTQNR 16	50	40	300	60	27	38	2,807	ISO.	₺2.031
K368	S50U MTQNR 16	63	50	350	65	35	47	5,121		₺2.503

107,5° MTQNL

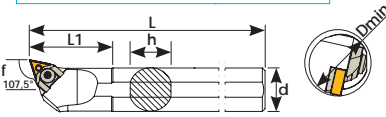

Sipariş Kodu	Ürün Kodu	Ölçüler (mm)							Uç	Fiyat
		Dmin	d	L	L1	f	h			
K537	S25S MTQNL 16	32	25	250	50	17	23	0,942		₺1.284
K538	S32T MTQNL 16	32	25	250	50	17	23	1,821	TNMG 1604	₺1.544
K539	S40T MTQNL 16	40	32	300	60	22	30	2,807	ISO.	₺2.031
K540	S50U MTQNL 16	50	40	300	60	27	38	5,121		₺2.503

95° MWLNR

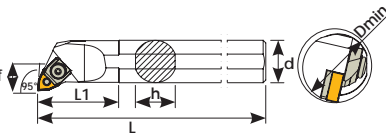
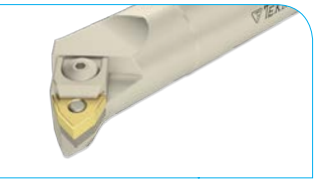

Sipariş Kodu	Ürün Kodu	Ölçüler (mm)							Uç	Fiyat
		Dmin	d	L	L1	f	h			
K427	S16Q MWLNR 06	21	16	180	40	11	15	0,286	WNMG 0604	₺1.073
K427-1	S20R MWLNR 06	25	20	200	50	13	18	0,502	ISO.	₺1.073
K428	S25S MWLNR 08	32	25	250	45	17	23	0,945		₺1.284
K430	S32T MWLNR 08	40	32	300	60	22	30	1,833	WNMG 0804	₺1.544
K432	S40T MWLNR 08	50	40	300	60	27	38	2,841	ISO.	₺2.031
K434	S50U MWLNR 08	63	50	350	65	35	47	5,110		₺2.503

95° MWLNL

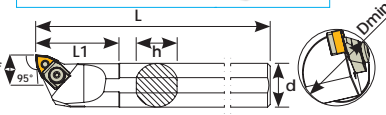

Sipariş Kodu	Ürün Kodu	Ölçüler (mm)							Uç	Fiyat
		Dmin	d	L	L1	f	h			
K510	S25S MWLNL 08	32	25	250	45	17	23	0,945		₺1.284
K512	S32T MWLNL 08	40	32	300	60	22	30	1,833	WNMG 0804	₺1.544
K514	S40T MWLNL 08	50	40	300	60	27	38	2,841	ISO.	₺2.031
K516	S50U MWLNL 08	63	50	350	65	35	47	5,110		₺2.503

95° DWLNR

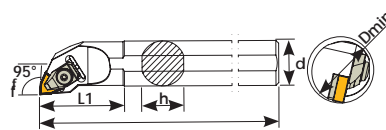

Sipariş Kodu	Ürün Kodu	Ölçüler (mm)							Uç	Fiyat
		Dmin	d	L	L1	f	h			
K418	S25S DWLNR 06	32	25	250	50	17	23	0,955	WNMG 0604 ISO	₺1.284
K420	S25S DWLNR 08	32	25	250	50	17	23	0,966		₺1.284
K422	S32T DWLNR 08	40	32	300	60	22	30	1,837	WNMG 0804	₺1.544
K424	S40T DWLNR 08	50	40	300	60	27	38	2,820	ISO.	₺2.031
K426	S50U DWLNR 08	63	50	350	75	35	47	5,123		₺2.503

Kod

95° DWLNL

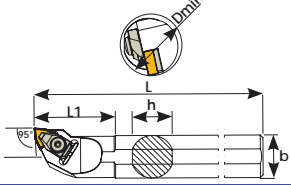

Sipariş Kodu	Ürün Kodu	Ölçüler (mm)							Uç	Fiyat
		Dmin	d	L	L1	f	h			
K498	S25S DWLNL 06	32	25	250	50	17	23	0,955	WNMG 0604 ISO	₺1.284
K500	S25S DWLNL 08	32	25	250	50	17	23	0,966	WNMG 0804	₺1.284
K502	S32T DWLNL 08	40	32	300	60	22	30	1,837	ISO.	₺1.544
K504	S40T DWLNL 08	50	40	300	60	27	38	2,820		₺2.031
K506	S50U DWLNL 08	63	50	350	75	35	47	5,123		₺2.503

Kod

K498 TC046 M5 TA021 TC034 M3x7 BK024 BY041 BSP031 3 Allen

K500 - K506 TC044 M6 TA020-1 TC038 M4x10 BK020 BY040 BSP030 3 Allen

95° DCLNR

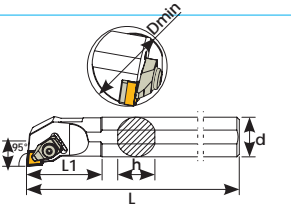
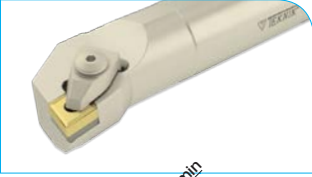

Sipariş Kodu	Ürün Kodu	Ölçüler (mm)							Uç	Fiyat
		Dmin	d	L	L1	f	h			
K400	S25S DCLNR 12	32	25	250	50	17	23	0,964		₺1.284
K402	S32T DCLNR 12	40	32	300	60	22	30	1,867	CNMG 1204	₺1.544
K404	S40T DCLNR 12	50	40	300	60	27	38	2,845	ISO.	₺2.031
K406	S50U DCLNR 12	63	50	350	60	35	47	5,166		₺2.503
K370	S32U DCLNR 16	40	32	350	60	22	30	2,272	CNMG 1606	₺1.625
K371	S40U DCLNR 16	50	40	350	60	27	38	3,550	ISO.	₺2.113
K374	S40U DCLNR 19	50	40	350	60	27	38	3,503	CNMG 1906	₺2.600
K375	S50V DCLNR 19	63	50	400	60	35	47	6,333	ISO.	₺2.844

Kod

K400-K406 TC044 M6 TA016-1 TC038 M4x10 BK020 BY040 BSP030 3 Allen

K370-K371 TC044 M6 TA022 TC095 M5x11,8 BK018 3 Allen

K374-K375 TC048 M8 TA017 TC039 M6x12 BK025 BY044 BSP032

95° DCLNL

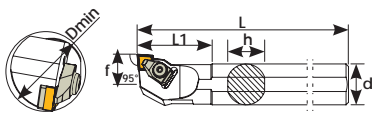

Sipariş Kodu	Ürün Kodu	Ölçüler (mm)							Uç	Fiyat
		Dmin	d	L	L1	f	h			
K480	S25S DCLNL 12	32	25	250	50	17	23	0,964		₺1.284
K482	S32T DCLNL 12	40	32	300	60	22	30	1,867	CNMG 1204	₺1.544
K484	S40T DCLNL 12	50	40	300	60	27	38	2,845	ISO.	₺2.031
K486	S50U DCLNL 12	63	60	350	75	35	47	5,166		₺2.503

Kod

TC044 M6 TA016-1 TC038 M4x10 BK020 BY040 BSP030 3 Allen

75° DCKNR

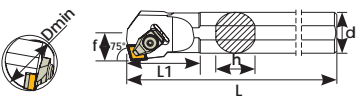
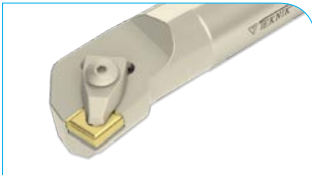

Sipariş Kodu	Ürün Kodu	Ölçüler (mm)							Uç	Fiyat
		Dmin	d	L	L1	f	h			
K401	S25S DCKNR 12	32	25	250	55	17	23	0,955		₺1.284
K403	S32T DCKNR 12	40	32	300	60	22	30	0,966	CNMG 1204	₺1.544
K405	S40T DCKNR 12	50	40	300	65	27	38	1,837	ISO.	₺2.031

Kod

TC044 M6 TA016-1 TC038 M4x10 BK020 BY040 BSP030 3 Allen

93° CKUNR

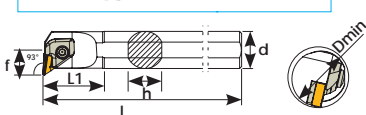

Sipariş Kodu	Ürün Kodu	Ölçüler (mm)							Uç	Fiyat
		Dmin	d	L	L1	f	h			
RK750	S25T CKUNR 16	32	25	300	52	19	23	1,400		₺964
RK754	S32U CKUNR 16	40	32	350	52	21	30	2,264	KNUX 1604	₺1.268
RK756	S40V CKUNR 16	50	40	400	55	27	38	3,999	ISO.	₺1.560
RK760	S50W CKUNR 16	63	50	450	60	35	47	0,408		₺1.926

Kod

TC044 M6 TA048 TC036 M3x10 BK030 BY042 BSP030 3 Allen

95° SCLCR IC Soğutmalı

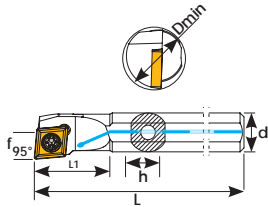

Sipariş Kodu	Ürün Kodu	Ölçüler (mm)								Uç	Fiyat
		Dmin	d	L	L1	f	h				
KA102	A08H SCLCR 06	10	8	100	16	5,5	7	0,050	CCMT 0602	₺494	
KA104	A10J SCLCR 06	12	10	110	20	6	9	0,074	ISO.	₺519	
KA106	A12K SCLCR 06	16	12	125	25	9	11	0,113		₺545	
KA108	A14-16Q SCLCR 09	18	16	180	45	9,5	15	0,267	CCMT 09T3	₺619	
KA110	A16Q SCLCR 09	20	16	180	30	11	15	0,260	ISO.	₺619	
KA111	A16M SCLCR 09	20	16	150	30	11	15	0,227		₺619	
KA114	A20Q SCLCR 09	25	20	180	40	13	18	0,422		₺684	
KA116	A25R SCLCR 09	32	25	200	40	17	23	0,734		₺910	
Kod											
KA102-KA106		TC060 M2,5x5,5				T8					
KA108 KA116		TC067 M3,5x8,5				T16					

95° SCLCR

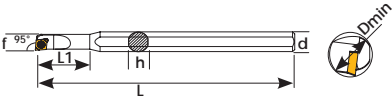

Sipariş Kodu	Ürün Kodu	Ölçüler (mm)							Uç	Fiyat
		Dmin	d	L	L1	f	h			
K097	S05-08H SCLCR 03	5	8	100	15	2,5	7,3	0,046	CCMT 0301	₺779
K098	S06-08H SCLCR 03	6	8	100	18	3	7,3	0,048	ISO.	₺779
K099	S07-08H SCLCR 04	7	8	100	21	3,5	7,3	0,050	CCMT 0401 ISO.	₺779
Kod										
K097-K098		TC057 M1,6				T6				
K099		TC058 M2x4,2								

95° SCLCR

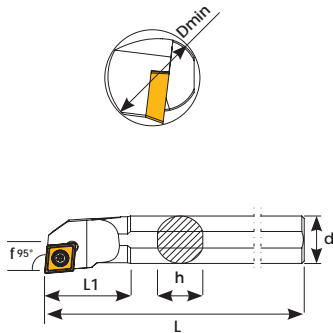

Sipariş Kodu	Ürün Kodu	Ölçüler (mm)							Uç	Fiyat
		Dmin	d	L	L1	f	h			
K100	S06-08H SCLCR 06	9	8	100	25	4,3	7,3	0,052		₺424
K102	S08H SCLCR 06	10	8	100	16	5,5	7,3	0,053	CCMT 0602	₺424
K104	S10J SCLCR 06	12	10	110	20	6	9	0,080	ISO.	₺454
K105	S10K SCLCR 06	12	10	125	20	6	9	0,085		₺454
K106	S12K SCLCR 06	16	12	125	25	9	11	0,120		₺468
K107	S12Q SCLCR 06	16	12	180	25	9	11	0,170		₺545
K107-1	S12K SCLCR 09	16	12	125	25	9	11	0,271		₺468
K108	S14-16Q SCLCR 09	18	16	180	45	9,5	15	0,285		₺545
K110	S16Q SCLCR 09	20	16	180	30	11	15	0,317		₺545
K111	S16R SCLCR 09	20	16	200	30	11	15	0,329	CCMT 09T3	₺570
K112	S18-20Q SCLCR 09	21	20	180	38	11	18	0,436	ISO.	₺598
K114	S20Q SCLCR 09	25	20	180	40	13	18	0,612		₺598
K115	S20S SCLCR 09	25	20	250	40	13	18	0,780		₺619
K116	S25R SCLCR 09	32	25	200	40	17	23	0,694		₺796
K117	S25T SCLCR 09	32	25	300	40	17	23	1,165		₺829
K116-1	S25S SCLCR 12	32	25	250	45	17	23	0,965	CCMT 1204 ISO.	₺829
Yedek Part										
K100-K102		TC059-1 M2,5x4,7				T8				
K104-K107		TC060 M2,5x5,5								
K107-1 K117		TC067 M3,5x8,5				T15				
K116-1		TC083 M5x12				T20				

95° SCLCL IC Soğutmalı

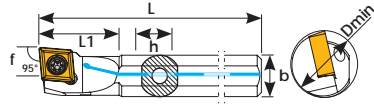

Sipariş Kodu	Ürün Kodu	Ölçüler (mm)							Uç	Fiyat
		Dmin	d	L	L1	f	h			
KA232	A08H SCLCL 06	10	8	100	16	5,5	7	0,050	CCMT 0602	₺494
KA234	A10J SCLCL 06	12	10	110	20	6	9	0,074	ISO.	₺519
KA236	A12K SCLCL 06	16	12	125	25	9	11	0,113		₺545
KA238	A14-16Q SCLCL 09	18	16	180	45	9,5	15	0,271		₺619
KA239	A16M SCLCL 09	20	16	150	30	11	15	0,227	CCMT 09T3	₺619
KA240	A16Q SCLCL 09	20	16	180	30	11	15	0,260	ISO.	₺619
KA244	A20Q SCLCL 09	25	20	180	40	13	18	0,422		₺684
KA246	A25R SCLCL 09	32	25	200	40	17	23	0,734		₺910

Kod

KA232-KA236 TC060 M2,5x5,5 T8
KA238-KA246 TC067 M3,5x8,5 T16

95° SCLCL

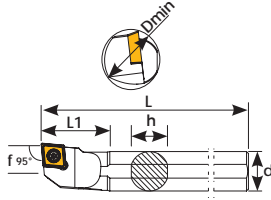

Sipariş Kodu	Ürün Kodu	Ölçüler (mm)							Uç	Fiyat
		Dmin	d	L	L1	f	h			
K230	S06-08H SCLCL 06	9	8	100	25	4,3	7	0,052		₺424
K232	S08H SCLCL 06	10	8	100	16	5,5	7	0,053	CCMT 0602	₺424
K234	S10J SCLCL 06	12	10	110	20	6	9	0,080	ISO.	₺454
K236	S12K SCLCL 06	16	12	125	25	9	11	0,120		₺468
K238	S14-16Q SCLCL 09	18	16	180	45	9,5	15	0,271		₺545
K240	S16Q SCLCL 09	20	16	180	30	11	15	0,285	CCMT 09T3	₺545
K241	S16R SCLCL 09	20	16	200	30	11	15	0,317	ISO.	₺570
K244	S20Q SCLCL 09	25	20	180	40	13	18	0,436		₺598
K245	S20S SCLCL 09	25	20	250	40	13	18	0,612		₺619
K246	S25R SCLCL 09	32	25	200	40	17	23	0,780		₺796

Kod

K230-K236 TC060 M2,5x5,5 T8
K238-K246 TC067 M3,5x8,5 T16

93° SDUCR IC Soğutmalı

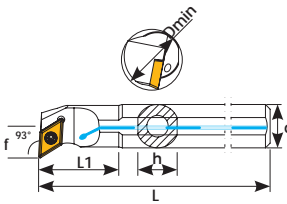

Sipariş Kodu	Ürün Kodu	Ölçüler (mm)							Uç	Fiyat
		Dmin	d	L	L1	f	h			
KA120	A10J SDUCR 07	12	10	110	20	7	9	0,080	DCMT 0702	₺519
KA122	A12K SDUCR 07	16	12	125	25	9	11	0,120	ISO.	₺545
KA124	A14-16Q SDUCR 07	18	16	180	40	10,5	15	0,267		₺619
KA126	A16Q SDUCR 07	20	16	180	30	11	15	0,263		₺619
KA127	A16M SDUCR 07	20	16	150	30	11	15	0,250		₺619
KA128	A16Q SDUCR 11	20	16	180	30	11	15	0,285		₺619
KA129	A16M SDUCR 11	20	16	150	30	11	15	0,246	DCMT 11T3	₺619
KA130	A20Q SDUCR 11	25	20	180	32	13	18	0,432	ISO.	₺684
KA132	A25R SDUCR 11	32	25	200	40	17	23	0,746		₺910
KA134	A32T SDUCR 11	40	32	300	45	22	30	1,924		₺1.414

Kod

KA120-KA127 TC060 M2,5x5,5 T8
KA128-KA134 TC067 M3,5x8,5 T15

93° SDUCR

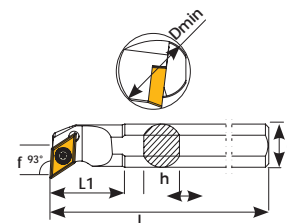

Sipariş Kodu	Ürün Kodu	Ölçüler (mm)							Uç	Fiyat
		Dmin	d	L	L1	f	h			
K120	S10J SDUCR 07	12	10	110	20	7	9	0,080		₺454
K122	S12K SDUCR 07	16	12	125	25	9	11	0,120	DCMT 0702	₺468
K123	S12Q SDUCR 07	16	12	180	25	9	11	0,170	ISO.	₺545
K124	S14-16Q SDUCR 07	18	16	180	40	10,5	15	0,266		₺545
K126	S16Q SDUCR 07	20	16	180	30	11	15	0,292		₺545
K125	S14-16Q SDUCR 11	18	16	180	45	10,5	15	0,272		₺545
K128	S16Q SDUCR 11	20	16	180	30	11,5	15	0,285	DCMT 11T3	₺545
K129	S16M SDUCR 11	20	16	150	30	11	15	0,246		₺545
K130	S20Q SDUCR 11	25	20	180	32	13	18	0,435	ISO.	₺598
K132	S25R SDUCR 11	32	25	200	40	17	23	0,748		₺796
K134	S32T SDUCR 11	40	32	300	45	22	30	1,833		₺1.219

Kod

K120-K126 TC060 M2,5x5,5 T8
K125-K134 TC067 M3,5x8,5 T15

93° SDUCL IC Soğutmalı

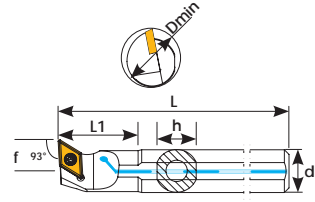

Sipariş Kodu	Ürün Kodu	Ölçüler (mm)								Uç	Fiyat
		Dmin	d	L	L1	f	h				
KA250	A10J SDUCL 07	12	10	110	20	7	9	0,080	DCMT 0702	₺519	
KA252	A12K SDUCL 07	16	12	125	25	9	11	0,120	ISO.	₺545	
KA254	A14-16Q SDUCL 07	18	16	180	40	10,5	15	0,267		₺619	
KA256	A16Q SDUCL 07	20	16	180	30	11	15	0,263		₺619	
KA258	A16Q SDUCL 11	20	16	180	30	11	15	0,285		₺619	
KA259	A16M SDUCL 11	20	16	150	30	11	15	0,246	DCMT 11T3	₺619	
KA260	A20Q SDUCL 11	25	20	180	32	13	18	0,432	ISO.	₺684	
KA262	A25R SDUCL 11	32	25	200	40	17	23	0,746		₺910	
KA263	A32T SDUCL 11	40	32	300	45	22	30	1,924		₺1.414	
Kod											
KA250-KA256		TC060 M2,5x5,5		T8							
KA258-KA263		TC067 M3,5x8,5		T15							

93° SDUCL

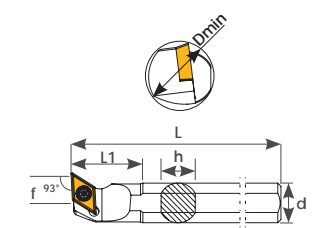

Sipariş Kodu	Ürün Kodu	Ölçüler (mm)								Uç	Fiyat
		Dmin	d	L	L1	f	h				
K250	S10J SDUCL 07	12	10	110	20	7	9	0,080		₺454	
K252	S12K SDUCL 07	16	12	125	25	9	11	0,120	DCMT 0702	₺468	
K254	S14-16Q SDUCL 07	18	16	180	40	10,5	15	0,266	ISO.	₺545	
K256	S16Q SDUCL 07	20	16	180	30	11	15	0,292		₺545	
K258	S16Q SDUCL 11	20	16	180	30	11	15	0,285	DCMT 11T3	₺545	
K259	A16M SDUCL 11	20	16	150	30	11	15	0,246		₺545	
K260	S20Q SDUCL 11	25	20	180	32	13	18	0,435	ISO.	₺598	
K262	S25R SDUCL 11	32	25	200	40	17	23	0,748		₺796	
K263	S32T SDUCL 11	40	32	300	45	22	30	1,833		₺1.219	
Kod											
K250-K256		TC060 M2,5x5,5		T8							
K258-K263		TC067 M3,5x8,5		T15							

107,5° SDQCR IC Soğutmalı

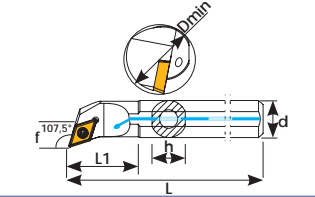

Sipariş Kodu	Ürün Kodu	Ölçüler (mm)								Uç	Fiyat
		Dmin	d	L	L1	f	h				
KA140	A10J SDQCR 07	12	10	110	20	7	9	0,074	DCMT 0702	₺519	
KA142	A12K SDQCR 07	16	12	125	25	9	11	0,110	ISO.	₺545	
KA143	A16M SDQCR 07	20	16	150	30	11	15	0,232		₺619	
KA144	A16Q SDQCR 07	20	16	180	30	11	15	0,282		₺619	
KA146	A16Q SDQCR 11	20	16	180	30	11	15	0,275		₺619	
KA148	A20Q SDQCR 11	25	20	180	32	13	18	0,425	DCMT 11T3	₺684	
KA150	A25R SDQCR 11	32	25	200	40	17	23	0,738	ISO.	₺910	
Kod											
KA140-KA144		TC060 M2,5x5,5		T8							
KA146-KA150		TC067 M3,5x8,5		T15							

107,5° SDQCR

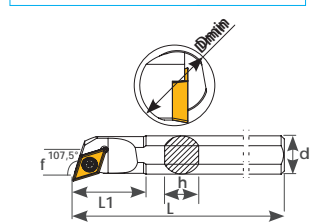

Sipariş Kodu	Ürün Kodu	Ölçüler (mm)								Uç	Fiyat
		Dmin	d	L	L1	f	h				
K140	S10J SDQCR 07	12	10	110	20	7	9	0,080	DCMT 0702	₺454	
K142	S12K SDQCR 07	16	12	125	25	9	11	0,120	ISO.	₺468	
K144	S16Q SDQCR 07	20	16	180	30	11	15	0,292		₺545	
K146	S16Q SDQCR 11	20	16	180	30	11	15	0,285		₺545	
K148	S20Q SDQCR 11	25	20	180	32	13	18	0,435	DCMT 11T3	₺598	
K150	S25R SDQCR 11	32	25	200	40	17	23	0,748	ISO.	₺796	
K152	S32T SDQCR 11	40	32	300	50	22	30	1,833		₺1.219	
K154	S40T SDQCR 11	50	40	300	50	27	38	0,268		₺1.788	
Kod											
K140-K144		TC060 M2,5x5,5		T8							
K146-K154		TC067 M3,5x8,5		T15							

107,5° SDQCL IC Soğutmalı

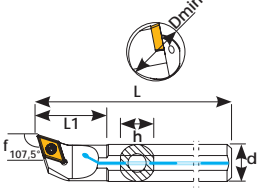

Sipariş Kodu	Ürün Kodu	Ölçüler (mm)							Uç	Fiyat
		Dmin	d	L	L1	f	h			
KA270	A10J SDQCL 07	12	10	110	20	7	9	0,074	DCMT 0702	₺519
KA272	A12K SDQCL 07	16	12	125	25	9	11	0,110	ISO.	₺545
KA273	A16M SDQCL 07	20	16	150	30	11	15	0,232		₺619
KA274	A16Q SDQCL 07	20	16	180	30	11	15	0,282		₺619
KA276	A16Q SDQCL 11	20	16	180	30	11	15	0,275	DCMT 11T3	₺619
KA278	A20Q SDQCL 11	25	20	180	32	13	18	0,425	ISO.	₺684
KA280	A25R SDQCL 11	32	25	200	40	17	23	0,738		₺910

Kod		
KA270-KA274	TC060 M2,5x5,5	T8
KA276-KA280	TC067 M3,5x8,5	T15

107,5° SDQCL

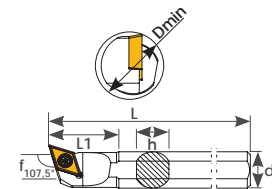

Sipariş Kodu	Ürün Kodu	Ölçüler (mm)							Uç	Fiyat
		Dmin	d	L	L1	f	h			
K270	S10J SDQCL 07	12	10	110	20	7	9	0,080	DCMT 0702	₺454
K272	S12K SDQCL 07	16	12	125	25	9	11	0,120	ISO.	₺468
K274	S16Q SDQCL 07	20	16	180	30	11	15	0,292		₺545
K276	S16Q SDQCL 11	20	16	180	30	11	15	0,285		₺545
K278	S20Q SDQCL 11	25	20	180	32	13	18	0,435	DCMT 11T3	₺598
K280	S25R SDQCL 11	32	25	200	40	17	23	0,748	ISO.	₺796
K281	S32T SDQCL 11	40	32	300	50	22	30	1,833		₺1.219

Kod		
K270-K274	TC060 M2,5x5,5	T8
K276-K281	TC067 M3,5x8,5	T15

120° SDXCR

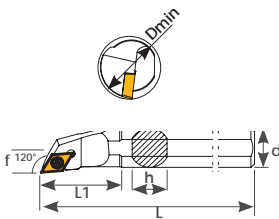
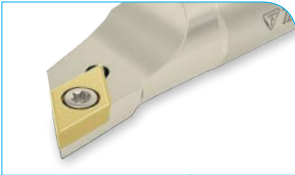

Sipariş Kodu	Ürün Kodu	Ölçüler (mm)							Uç	Fiyat
		Dmin	d	L	L1	f	h			
K469	S10J SDXCR 07	12	10	110	25	5,5	9	0,080	DCMT 0702	₺454
K470	S12K SDXCR 07	16	12	125	30	9	11	0,120	ISO.	₺468
K471	S16Q SDXCR 11	20	16	180	40	11	15	0,285		₺545
K472	S20Q SDXCR 11	25	20	180	40	13	18	0,435		₺598
K473	S25R SDXCR 11	32	25	200	50	13,5	23	0,748	DCMT 11T3	₺796
K474	S32T SDXCR 11	40	32	300	55	17	30	1,833	ISO.	₺1.219
K475	S40T SDXCR 11	50	40	300	55	21	38	0,268		₺1.788

Kod		
K469-K470	TC060 M2,5x5,5	T8
K471-K475	TC067 M3,5x8,5	T15

62,5° SD-CR

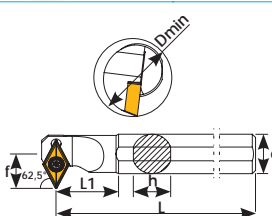
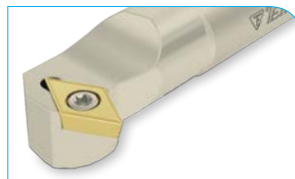



Sipariş Kodu	Ürün Kodu	Ölçüler (mm)							Uç	Fiyat
		Dmin	d	L	L1	f	h			
K168	S10J SD-CR 07	14	10	110	25	8,2	9	0,082	DCMT 0702	₺454
K170	S12K SD-CR 07	16	12	125	25	9	11	0,122	ISO.	₺468
K173	S16Q SD-CR 07	20	16	180	35	12	15	0,280		₺545
K172	S16Q SD-CR 11	23	16	180	35	14	15	0,288		₺545
K174	S20Q SD-CR 11	25	20	180	32	15	18	0,443	DCMT 11T3	₺598
K176	S25R SD-CR 11	32	25	200	35	17	23	0,771	ISO.	₺796
K178	S32T SD-CR 11	40	32	300	55	23	30	1,865		₺1.219

Kod		
K168-K173	TC060 M2,5x5,5	T8
K172-K178	TC067 M3,5x8,5	T15

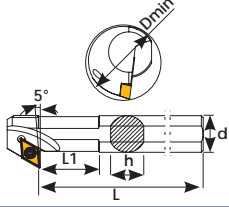
5° SDZCR





Sipariş Kodu	Ürün Kodu	Ölçüler (mm)							Uç	Fiyat
		Dmin	d	L	L1	f	h			
K190	S12K SDZCR 07	18	12	125	20	11	11	0,128	DCMT 0702 ISO	₺676
K192	S16Q SDZCR 11	23	16	180	25	14	15	0,302		₺753
K194	S20Q SDZCR 11	30	20	180	32	19	18	0,498	DCMT 11T3	₺829
K196	S25R SDZCR 11	35	25	200	32	22	23	0,816	ISO	₺991

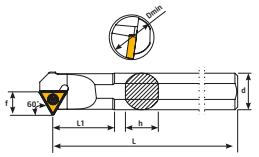
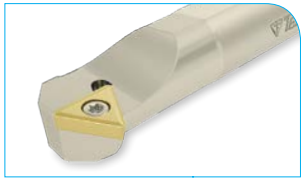

Kod  

K190	TC060 M2,5x5,5	T8	
K192-K196	TC067 M3,5x8,5	T15	

60° ST-CR





Sipariş Kodu	Ürün Kodu	Ölçüler (mm)							Uç	Fiyat
		Dmin	d	L	L1	f	h			
K180	S16Q ST-CR 16	20	16	180	40	11	15	0,817	TCMT 16T3	₺545
K182	S20Q ST-CR 16	25	20	180	40	13	18	0,432	ISO	₺598
K183	S25R ST-CR 16	32	25	200	50	17	23	0,772		₺796
K183-1	S32T ST-CR 16	30	32	300	60	22	30	1,961		₺1.219

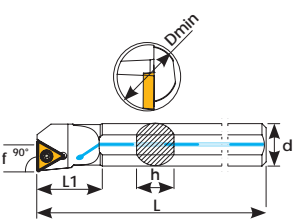

Kod  

	TC067 M3,5x8,5	T15	
--	----------------	-----	---

90° STFCR IC Soğutmalı





Sipariş Kodu	Ürün Kodu	Ölçüler (mm)							Uç	Fiyat
		Dmin	d	L	L1	f	h			
KA160	A12K STFCR 11	16	12	125	25	9	11	0,053	TCMT 1102	₺545
KA161	A16Q STFCR 11	20	16	180	30	11	15	0,289	ISO.	₺619
KA162	A16Q STFCR 16	20	16	180	30	11	15	0,287		₺619
KA164	A20Q STFCR 16	25	20	180	32	13	18	0,440	TCMT 16T3	₺684
KA166	A25R STFCR 16	32	25	200	40	16	23	0,754	ISO.	₺910

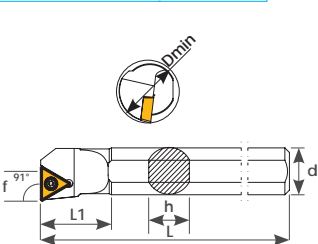

Kod  

KA160-KA161	TC060 M2,5x5,5	T8	
KA162 KA166	TC067 M3,5x8,5	T16	

90° STFCR



Sipariş Kodu	Ürün Kodu	Ölçüler (mm)							Uç	Fiyat
		Dmin	d	L	L1	f	h			
K160	S12K STFCR 11	16	12	125	25	9	11	0,118	TCMT 1102	₺468
K161	S16Q STFCR 11	20	16	180	30	11	15	0,290	ISO.	₺545
K162	S16Q STFCR 16	20	16	180	30	11	15	0,287	TCMT 16T3	₺545
K164	S20Q STFCR 16	25	20	180	32	13	18	0,440	ISO.	₺598
K166	S25R STFCR 16	32	25	200	40	16	23	0,773		₺796

Kod  

K160-K161	TC060 M2,5x5,5	T8	
K162-K166	TC067 M3,5x8,5	T15	

90° STFCL IC Soğutmalı

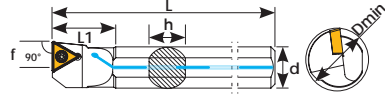

Sipariş Kodu	Ürün Kodu	Ölçüler (mm)							Uç	Fiyat
		Dmin	d	L	L1	f	h	kg		
KA184	A12K STFCL 11	16	12	125	25	9	11	0,053	TCMT 1102	₺545
KA185	A16Q STFCL 11	20	16	180	30	11	15	0,289	ISO.	₺619
KA186	A16Q STFCL 16	20	16	180	30	11	15	0,287		₺619
KA187	A20Q STFCL 16	25	20	180	32	13	18	0,440	TCMT 16T3	₺684
KA188	A25R STFCL 16	32	25	200	40	16	23	0,754	ISO.	₺910
Kod										
KA184-KA185		TC060 M2,5x5,5						T8		
KA186-KA188		TC067 M3,5x8,5						T16		

90° STFCL

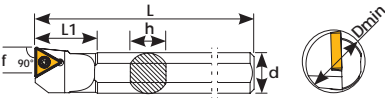
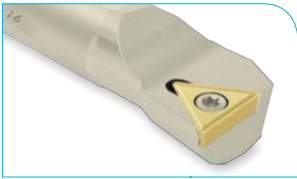

Sipariş Kodu	Ürün Kodu	Ölçüler (mm)							Uç	Fiyat
		Dmin	d	L	L1	f	h	kg		
K184	S12K STFCL 11	16	12	125	25	9	11	0,118	TCMT 1102	₺468
K185	S16Q STFCL 11	20	16	180	30	11	15	0,290	ISO.	₺545
K186	S16Q STFCL 16	20	16	180	30	11	15	0,287		₺545
K187	S20Q STFCL 16	25	20	180	32	13	18	0,440	TCMT 16T3	₺598
K188	S25R STFCL 16	32	25	200	40	16	23	0,773	ISO.	₺796
Kod										
K184-K185		TC060 M2,5x5,5						T8		
K186-K188		TC067 M3,5x8,5						T15		

93° SVUBR IC Soğutmalı

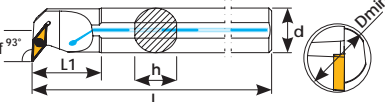

Sipariş Kodu	Ürün Kodu	Ölçüler (mm)							Uç	Fiyat
		Dmin	d	L	L1	f	h	kg		
KA208	A25R SVUBR 16	32	25	200	40	17	23	0,723	VBMT 1604	₺959
KA209	A32T SVUBR 16	40	32	300	50	22	30	1,909	ISO.	₺1.424
Kod										
TC074 M4x10								T15		

93° SVUBR

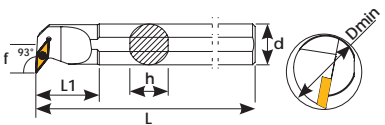

Sipariş Kodu	Ürün Kodu	Ölçüler (mm)							Uç	Fiyat
		Dmin	d	L	L1	f	h	kg		
K206	S16Q SVUBR 11	20	16	180	30	11	15	0,278	VBMT 1103	₺619
K207	S20Q SVUBR 11	25	20	180	32	13	18	0,700	ISO.	₺753
K208	S25R SVUBR 16	32	25	200	40	17	23	0,730		₺829
K209	S32T SVUBR 16	40	32	300	50	22	30	1,822	VBMT 1604	₺1.300
K210	S40T SVUBR 16	50	40	300	50	27	38	2,836	ISO.	₺1.788
Kod										
TC061 M2,5x6,5								T8		
TC074 M4x10								T15		

93° SVUBL IC Soğutmalı

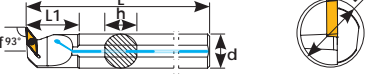

Sipariş Kodu	Ürün Kodu	Ölçüler (mm)							Uç	Fiyat
		Dmin	d	L	L1	f	h	kg		
KA286	A25R SVUBL 16	32	25	200	40	17	23	0,723	VBMT 1604	₺959
KA288	A32T SVUBL 16	40	32	300	50	22	30	1,909	ISO.	₺1.424
Kod										
TC074 M4x10								T15		

93° SVUBL

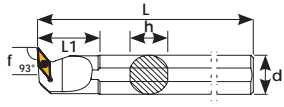

Sipariş Kodu	Ürün Kodu	Ölçüler (mm)							Uç	Fiyat
		Dmin	d	L	L1	f	h	kg		
K282	S16Q SVUBL 11	20	16	180	30	11	15	0,278	VBMT 1103	₺619
K284	S20Q SVUBL 11	25	20	180	32	13	18	0,700	ISO.	₺753
K286	S25R SVUBL 16	32	25	200	40	17	23	0,730	VBMT 1604	₺829
K288	S32T SVUBL 16	40	32	300	50	22	30	1,822	ISO.	₺1.300
Kod										
K282-K284		TC061 M2,5x6,5			T8					
K286-K288		TC074 M4x10			T15					

93° SVUCR IC Soğutmalı

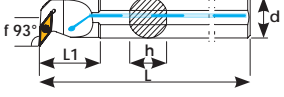

Sipariş Kodu	Ürün Kodu	Ölçüler (mm)							Uç	Fiyat
		Dmin	d	L	L1	f	h	kg		
KA211	A16Q SVUCR 11	20	16	180	30	11	15	0,268	VCMT 1103	₺716
KA212	A20Q SVUCR 11	25	20	180	32	13	18	0,689	ISO.	₺854
KA213	A25R SVUCR 16	32	25	200	40	17	23	0,720	VCMT 1604	₺959
KA214	A32T SVUCR 16	40	32	300	50	22	30	1,812	ISO.	₺1.424
Kod										
KA211-KA212		TC061 M2,5x6,5			T8					
KA213-KA214		TC074 M4x10			T15					

93° SVUCR

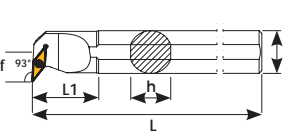

Sipariş Kodu	Ürün Kodu	Ölçüler (mm)							Uç	Fiyat
		Dmin	d	L	L1	f	h	kg		
K211	S16Q SVUCR 11	20	16	180	30	11	15	0,280	VCMT 1103	₺619
K212	S20Q SVUCR 11	25	20	180	32	13	18	0,432	ISO.	₺753
K213	S25R SVUCR 16	32	25	200	40	17	23	0,771		₺829
K214	S32T SVUCR 16	40	32	300	50	22	30	1,833	VCMT 1604	₺1.300
K215	S40T SVUCR 16	50	40	300	55	27	38	2,807	ISO.	₺1.788
Kod										
K211-K212		TC061 M2,5x6,5			T8					
K213-K215		TC074 M4x10			T15					

93° SVUCL IC Soğutmalı

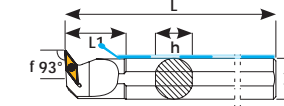

Sipariş Kodu	Ürün Kodu	Ölçüler (mm)							Uç	Fiyat
		Dmin	d	L	L1	f	h	kg		
KA300	A16Q SVUCL 11	20	16	180	30	11	15	0,268	VCMT 1103	₺716
KA302	A20Q SVUCL 11	25	20	180	32	13	18	0,689	ISO.	₺854
KA304	A25R SVUCL 16	32	25	200	40	17	23	0,720	VCMT 1604	₺959
KA306	A32T SVUCL 16	40	32	300	50	22	30	1,812	ISO.	₺1.424
Kod										
KA300-KA302		TC061 M2,5x6,5			T8					
KA304-KA306		TC074 M4x10			T15					

SVUCL

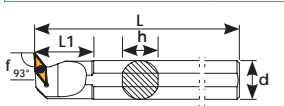

Sipariş Kodu	Ürün Kodu	Ölçüler (mm)							Uç	Fiyat
		Dmin	d	L	L1	f	h	kg		
K300	S16Q SVUCL 11	20	16	180	30	11	15	0,280	VCMT 1103	₺619
K302	S20Q SVUCL 11	25	20	180	32	13	18	0,432	ISO.	₺753
K304	S25R SVUCL 16	32	25	200	40	17	23	0,771	VCMT 1604	₺829
K306	S32T SVUCL 16	40	32	300	50	22	30	1,833	ISO.	₺1.300
Kod										
K300-K302		TC061 M2,5x6,5			T8					
K304-K306		TC074 M4x10			T15					

107,5° SVQCR IC Soğutmalı

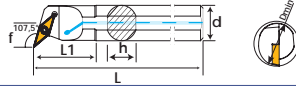

Sipariş Kodu	Ürün Kodu	Ölçüler (mm)							Uç	Fiyat
		Dmin	d	L	L1	f	h	kg		
KA221	A16Q SVQCR 11	20	16	180	30	11	15	0,271	VCMT 1103	₺716
KA222	A20Q SVQCR 11	25	20	180	30	13	18	1,752	ISO.	₺854

TC061 M2,5x7 T8

107,5° SVQCR

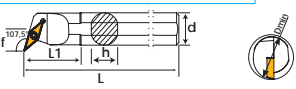

Sipariş Kodu	Ürün Kodu	Ölçüler (mm)							Uç	Fiyat
		Dmin	d	L	L1	f	h	kg		
K221	S16Q SVQCR 11	20	16	180	30	11	15	0,281	VCMT 1103	₺619
K222	S20Q SVQCR 11	25	20	180	30	13	18	1,762	ISO.	₺753
K223	S25R SVQCR 16	32	25	200	50	17	23	0,728		₺829
K224	S32T SVQCR 16	40	32	300	50	22	30	1,786	VCMT 1604	₺1.300
K225	S40T SVQCR 16	50	40	300	55	27	38		ISO.	₺1.788

Kod
K221-K222 TC061 M2,5x6,5 T8
K223-K225 TC074 M4x10 T15

107,5° SVQCL IC Soğutmalı

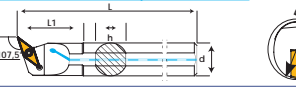

Sipariş Kodu	Ürün Kodu	Ölçüler (mm)							Uç	Fiyat
		Dmin	d	L	L1	f	h	kg		
KA319	A16Q SVQCL 11	20	16	180	30	11	15	0,271	VCMT 1103	₺716
KA320	A20Q SVQCL 11	25	20	180	30	13	18	1,752	ISO.	₺854

TC061 M2,5x7 T8

107,5° SVQCL

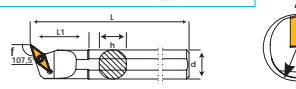

Sipariş Kodu	Ürün Kodu	Ölçüler (mm)							Uç	Fiyat
		Dmin	d	L	L1	f	h	kg		
K319	S16Q SVQCL 11	20	16	180	30	11	15	0,281	VCMT 1103	₺619
K320	S20Q SVQCL 11	25	20	180	30	13	18	1,762	ISO.	₺753
K322	S25R SVQCL 16	32	25	200	50	17	23	0,728	VCMT 1604	₺829
K324	S32T SVQCL 16	40	32	300	50	22	30	1,786	ISO.	₺1.300

Kod
K319-K320 TC061 M2,5x6,5 T8
K322-K324 TC074 M4x10 T15

107,5° SVQBR

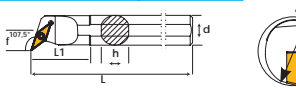

Sipariş Kodu	Ürün Kodu	Ölçüler (mm)							Uç	Fiyat
		Dmin	d	L	L1	f	h	kg		
K216	S16Q SVQBR 11	20	16	180	30	11	15	0,276	VBMT 1103	₺619
K217	S20Q SVQBR 11	25	20	180	30	13	18	0,422	ISO.	₺753
K218	S25R SVQBR 16	32	25	200	50	17	23	0,725		₺829
K219	S32T SVQBR 16	40	32	300	50	22	30	1,790	VBMT 1604	₺1.300
K220	S40T SVQBR 16	50	40	300	55	27	38	2,765	ISO.	₺1.788

Kod
K216-K217 TC061 M2,5x6,5 T8
K218-K220 TC074 M4x10 T15

107,5° SVQBL

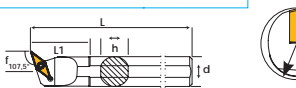

Sipariş Kodu	Ürün Kodu	Ölçüler (mm)							Uç	Fiyat
		Dmin	d	L	L1	f	h	kg		
K310	S16Q SVQBL 11	20	16	180	30	11	15	0,276	VBMT 1103	₺619
K312	S20Q SVQBL 11	25	20	180	30	13	18	0,422	ISO.	₺753
K314	S25R SVQBL 16	32	25	200	50	17	23	0,725		₺829
K316	S32T SVQBL 16	40	32	300	50	22	30	1,790	VBMT 1604	₺1.300
K318	S40T SVQBL 16	50	40	300	55	27	38	2,765	ISO.	₺1.788

Kod
K310-K312 TC061 M2,5x6,5 T8
K314-K318 TC074 M4x10 T15



E-SCLCR SET

Sipariş Kodu	Ürün Kodu in Set	Uç	Fiyat
İPS30 	E08K SCLCR 06	CCMT 0602	374 €
	E10K SCLCR 06	ISO.	
	E12M SCLCR 06		

E-SCLCL SET

Sipariş Kodu	Ürün Kodu in Set	Uç	Fiyat
İPS31 	E08K SCLCL 06	CCMT 0602	374 €
	E10K SCLCL 06	ISO.	
	E12M SCLCL 06		



E-SDUCR SET

Sipariş Kodu	Ürün Kodu in Set	Uç	Fiyat
İPS32 	E10K SDUCR 07	DCMT 0702	258 €
	E12M SDUCR 07	ISO.	

E-SDUCL SET

Sipariş Kodu	Ürün Kodu in Set	Uç	Fiyat
İPS33 	E10K SDUCL 07	DCMT 0702	258 €
	E12M SDUCL 07	ISO.	



E-SDQCR SET

Sipariş Kodu	Ürün Kodu in Set	Uç	Fiyat
İPS34 	E10K SDQCR 07	DCMT 0702	258 €
	E12M SDQCR 07	ISO.	

E-SDQCL SET

Sipariş Kodu	Ürün Kodu in Set	Uç	Fiyat
İPS35 	E10K SDQCL 07	DCMT 0702	258 €
	E12M SDQCL 07	ISO.	

95° E-SCLCR IC

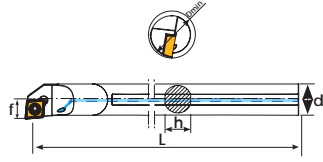

Sipariş Kodu	Ürün Kodu	Ölçüler (mm)						Uç	Fiyat
		Dmin	d	L	f	h	kg		
KE10	E08K SCLCR 06	10	8	125	5	7,5	0,050	CCMT 0602	114 €
KE11	E10K SCLCR 06	12	10	125	6	9,5	0,100	ISO.	128 €
KE12	E12M SCLCR 06	16	12	150	7	11,5	0,200		132 €
KE13	E16R SCLCR 09	20	16	200	10	15,5	0,500	CCMT 09T3	242 €
KE14	E20S SCLCR 09	25	20	250	13	19,5	0,950	ISO	410 €
Kod									
KE10-KE12		TC060 M2,5x5,5				T8			
KE13-KE14		TC067 M3,5x8,5				T15			

95° E-SCLCL IC

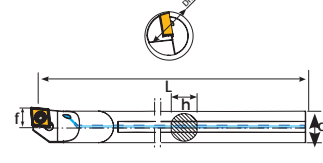

Sipariş Kodu	Ürün Kodu	Ölçüler (mm)						Uç	Fiyat
		Dmin	d	L	f	h	kg		
KE17	E08K SCLCL 06	10	8	125	5	7,5	0,050	CCMT 0602	114 €
KE18	E10K SCLCL 06	12	10	125	6	9,5	0,100	ISO.	128 €
KE19	E12M SCLCL 06	16	12	150	7	11,5	0,200		132 €
KE20	E16R SCLCL 09	20	16	200	10	15,5	0,500	CCMT 09T3	242 €
KE21	E20S SCLCL 09	25	20	250	13	19,5	0,950	ISO	410 €
Kod									
KE17-KE19		TC060 M2,5x5,5				T8			
KE20-KE21		TC067 M3,5x8,5				T15			

93° E-SDUCR IC

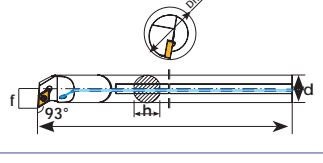

Sipariş Kodu	Ürün Kodu	Ölçüler (mm)						Uç	Fiyat
		Dmin	d	L	f	h	kg		
KE30	E10K SDUCR 07	13	10	125	7	9,5	0,050	DCMT 0702	128 €
KE31	E12M SDUCR 07	16	12	150	9	11,5	0,100	ISO.	132 €
KE32	E16R SDUCR 07	20	16	200	11	15,5	0,200		242 €
KE33	E16R SDUCR 11	20	16	200	11	15,5	0,500	DCMT 11T3	242 €
KE34	E20S SDUCR 11	25	20	250	13	19,5	0,950	ISO	410 €
Kod									
KE30-KE32		TC060 M2,5x5,5				T8			
KE33-KE34		TC067 M3,5x8,5				T15			

93° E-SDUCL IC

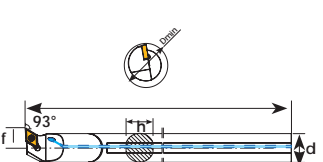

Sipariş Kodu	Ürün Kodu	Ölçüler (mm)						Uç	Fiyat
		Dmin	d	L	f	h	kg		
KE40	E10K SDUCL 07	13	10	125	7	9,5	0,050	DCMT 0702	128 €
KE41	E12M SDUCL 07	16	12	150	9	11,5	0,100	ISO.	132 €
KE42	E16R SDUCL 07	20	16	200	11	15,5	0,200		242 €
KE43	E16R SDUCL 11	20	16	200	11	15,5	0,500	DCMT 11T3	242 €
KE44	E20S SDUCL 11	25	20	250	13	19,5	0,950	ISO	410 €
Kod									
KE40-KE42		TC060 M2,5x5,5				T8			
KE43-KE44		TC067 M3,5x8,5				T15			

107,5° E-SDQCR IC

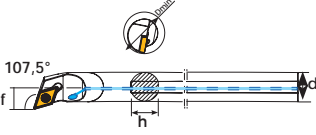

Sipariş Kodu	Ürün Kodu	Ölçüler (mm)						Uç	Fiyat
		Dmin	d	L	f	h	kg		
KE50	E10K SDQCR 07	13	10	125	7	9,5	0,050	DCMT 0702	128 €
KE51	E12M SDQCR 07	16	12	150	9	11,5	0,100	ISO.	132 €
KE52	E16R SDQCR 07	20	16	200	11	15,5	0,200		242 €
KE53	E16R SDQCR 11	20	16	200	11	15,5	0,500	DCMT 11T3	242 €
KE54	E20S SDQCR 11	25	20	250	13	19,5	0,950	ISO	410 €
Kod									
KE50-KE52		TC060 M2,5x5,5				T8			
KE53-KE54		TC067 M3,5x8,5				T15			

107,5° E-SDQCL IC

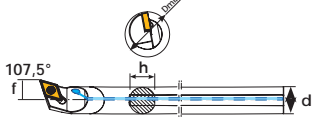

Sipariş Kodu	Ürün Kodu	Ölçüler (mm)						Uç	Fiyat
		Dmin	d	L	f	h	kg		
KE60	E10K SDQCL 07	13	10	125	7	9,5	0,050	DCMT 0702	128 €
KE61	E12M SDQCL 07	16	12	150	9	11,5	0,100	ISO.	132 €
KE62	E16R SDQCL 07	20	16	200	11	15,5	0,200		242 €
KE63	E16R SDQCL 11	20	16	200	11	15,5	0,500	DCMT 11T3	242 €
KE64	E20S SDQCL 11	25	20	250	13	19,5	0,950	ISO	410 €
Kod									
KE60-KE62		TC060 M2,5x5,5				T8			
KE63-KE64		TC067 M3,5x8,5				T15			

Karbür İç Çap Diş Katerleri/R Soğutmalı

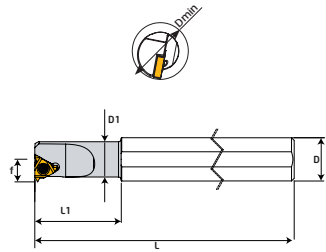
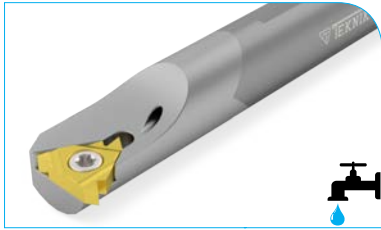

Sipariş Kodu	Ürün Kodu	Ölçüler (mm)					Uç	Fiyat	
		D	L	L1	f	Dmin			
KE70	E06H - IR06	6	100	26	4,3	6	0,024	6 IR	114 €
KE71	E08K - IR08	8	125	31	5,3	7,8	0,045	8 IR	114 €
KE72	E10M - IR11	10	150	-	7,4	12	0,085	11 IR	135 €
KE73	E12P - IR11	12	170	-	8,4	15	0,150	11 IR	160 €
KE74	E16R - IR16	16	200	-	11,7	19	0,260	16 IR	242 €
KE75	E20S - IR16	20	250	-	13,7	24	0,560	16 IR	410 €
KE76	E25S - IR16	25	250	-	16,2	29	0,900	16 IR	520 €
KE78	E20S - IR22	20	250	-	15,6	24,5	0,570	22 IR	410 €
Kod									
KE70		TC058-1M2x4,2		--		--		T6	
KE71		TC058 M2x4,6		--		--		T8	
KE72-KE72		TC060 M2,5x5,5		--		--		T8	
KE74		TC067 M3,5x8,5		--		--		T15	
KE75-KE76		TC068 M3,5x11		TA060		BSP010		TC062 M3	
KE78		TC078 M4x11		--		--		T15	

Karbür Threa Cutting Tool Soğutmalı

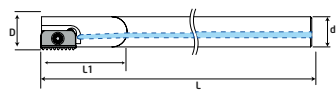

Sipariş Kodu	Ürün Kodu	Ölçüler (mm)					Uç	Fiyat	
		A	D	d	L	L1			
KE90	D9,9 d08 L125 A12 S12	12	9,9	8	125	-	0,049	S12	114 €
KE91	D13,2 d10 L110 A14 S14	14	13,2	10	110	-	0,067	S14	128 €
KE92	D13,2 d10 L155 A14 S14	14	13,2	10	155	-	0,100	S14	137 €
KE93	D15,2 d12 L175 A14 S14	14	15,2	12	175	-	0,167	S14	154 €
KE94	D21 d16 L130 A21 S21	21	21	16	130	-	0,212	S21	209 €
KE95	D21 d16 L200 A21 S21	21	21	16	200	-	0,327	S21	258 €
Kod									
KE90		TC092 M2,5x5,5		--		--		T8	
KE91-KE93		TC093 M2,5x7		--		--		T15	
KE94-KE95		TC074 M4x10		--		--		T15	

SCLCR SET

Sipariş Kodu	Ürün Kodu in Set	Uç	Fiyat
İPS01 	A08H SCLCR 06	CCMT 0602	₺1.966
	A10J SCLCR 06	ISO.	
	A12K SCLCR 06		
	A16M SCLCR 09	CCMT 09T3	

SCLCL SET

Sipariş Kodu	Ürün Kodu in Set	Uç	Fiyat
İPS04 	A08H SCLCL 06	CCMT 0602	₺1.966
	A10J SCLCL 06	ISO.	
	A12K SCLCL 06		
	A16M SCLCL 09	CCMT 09T3	

SDUCR SET

Sipariş Kodu	Ürün Kodu in Set	Uç	Fiyat
İPS02 	A10J SDUCR 07	DCMT 0702	₺1.529
	A12K SDUCR 07	ISO.	
	A16M SDUCR 07		

SDUCL SET

Sipariş Kodu	Ürün Kodu in Set	Uç	Fiyat
İPS05 	A10J SDUCL 07	DCMT 0702	₺1.529
	A12K SDUCL 07	ISO.	
	A16M SDUCL 07		

SDQCR SET

Sipariş Kodu	Ürün Kodu in Set	Uç	Fiyat
İPS03 	A10J SDQCR 07	DCMT 0702	₺1.529
	A12K SDQCR 07	ISO.	
	A16M SDQCR 07		

SDQCL SET

Sipariş Kodu	Ürün Kodu in Set	Uç	Fiyat
İPS06 	A10J SDQCL 07	DCMT 0702	₺1.529
	A12K SDQCL 07	ISO.	
	A16M SDQCL 07		





SCLCR SET

Sipariş Kodu	Ürün Kodu in Set	Uç	Fiyat
İPS20	S08H SCLCR 06	CCMT 0602	₺1.735
	S10J SCLCR 06	ISO.	
	S12K SCLCR 06		
	S16M SCLCR 09	CCMT 09T3	

SCLCL SET

Sipariş Kodu	Ürün Kodu in Set	Uç	Fiyat
İPS21	S08H SCLCL 06	CCMT 0602	₺1.735
	S10J SCLCL 06	ISO.	
	S12K SCLCL 06		
	S16M SCLCL 09	CCMT 09T3	

SDUCR SET

Sipariş Kodu	Ürün Kodu in Set	Uç	Fiyat
İPS22	S10J SDUCR 07	DCMT 0702	₺1.323
	S12K SDUCR 07	ISO.	
	S16M SDUCR 11	DCMT 11T3	

SDUCL SET

Sipariş Kodu	Ürün Kodu in Set	Uç	Fiyat
İPS23	S10J SDUCL 07	DCMT 0702	₺1.323
	S12K SDUCL 07	ISO.	
	S16M SDUCL 11	DCMT 11T3	



SDQCR SET

Sipariş Kodu	Ürün Kodu in Set	Uç	Fiyat
İPS24	S10J SDQCR 07	DCMT 0702	₺1.323
	S12K SDQCR 07	ISO.	
	S16M SDQCR 11	DCMT 11T3	

SDQCL SET

Sipariş Kodu	Ürün Kodu in Set	Uç	Fiyat
İPS25	S10J SDQCL 07	DCMT 0702	₺1.323
	S12K SDQCL 07	ISO.	
	S16M SDQCL 11	DCMT 11T3	

U-DRIL Eksantrik Adaptör

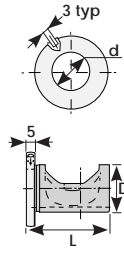

Sipariş Kodu	Ürün Kodu	Ölçüler (mm)			Fiyat
		D	d	L	
UA10	D25 d20 L46	25	20	46,5	₺1.041
UA12	D32 d25 L47	32	25	47	₺1.041
UA14	D40 d32 L57	40	32	57	₺1.041

D2 WCM_

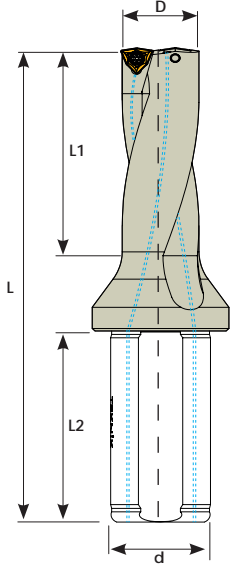
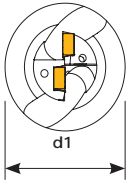
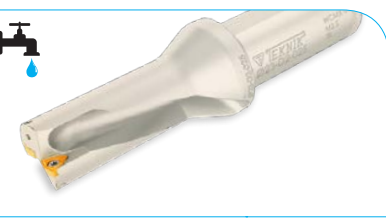

Sipariş Kodu	Ürün Kodu	Ölçüler (mm)							Uç	Fiyat
		D	d	d1	L	L1	L2			
U104	16 D2 WCM_03	16	25	34	108	32	56	0,294	WCM_0302	₺1.861
U105	17 D2 WCM_03	17	25	34	110	34	56	0,293	KRLY	₺1.861
U106	18 D2 WCM_03	18	25	34	113	36	56	0,303		₺1.861
U107	19 D2 WCM_03	19	25	34	115	38	56	0,312		₺1.861
U108	20 D2 WCM_04	20	25	34	119	40	56	0,327		₺2.009
U110	21 D2 WCM_04	21	25	34	121	42	56	0,340	WCM_0402	₺2.009
U112	22 D2 WCM_04	22	25	34	123	44	56	0,345	KRLY	₺2.009
U114	23 D2 WCM_04	23	25	34	127	46	56	0,370		₺2.009
U116	24 D2 WCM_05	24	25	34	130	48	56	0,390		₺2.109
U118	25 D2 WCM_05	25	25	34	133	50	56	0,420		₺2.109
U120	26 D2 WCM_05	26	25	34	135	52	56	0,420	WCM_0503	₺2.109
U122	27 D2 WCM_05	27	25	34	137	54	56	0,450	KRLY	₺2.109
U124	28 D2 WCM_05	28	25	39	140	56	56	0,491		₺2.109
U126	29 D2 WCM_05	29	25	39	142	58	56	0,515		₺2.109
U128	30 D2 WCM_06	30	32	44	151	60	58	0,755		₺2.231
U130	31 D2 WCM_06	31	32	44	154	62	58	0,775		₺2.231
U132	32 D2 WCM_06	32	32	44	156	64	58	0,802		₺2.231
U134	33 D2 WCM_06	33	32	44	159	66	58	0,845	WCM_06T3	₺2.231
U136	34 D2 WCM_06	34	32	44	161	68	58	0,851	KRLY	₺2.231
U137	35 D2 WCM_06	35	32	44	164	70	58	0,900		₺2.333
U138	36 D2 WCM_06	36	32	44	167	72	58	0,970		₺2.333
U139	37 D2 WCM_06	37	32	44	170	74	58	0,875		₺2.333
U140	38 D2 WCM_06	38	32	44	173	76	58	0,975		₺2.333
U141	39 D2 WCM_06	39	32	44	175	78	58	1,006		₺2.333
U142	40 D2 WCM_06	40	32	44	178	80	58	1,007		₺2.333

Kod

U104-U114	TC060 M2,5x5,5	T8
U116-U126	TC065 M3x7	T8
U128-U142	TC067 M3,5x8,5	T10



KRLY Ucuna Uygunur.

D3 WCM_

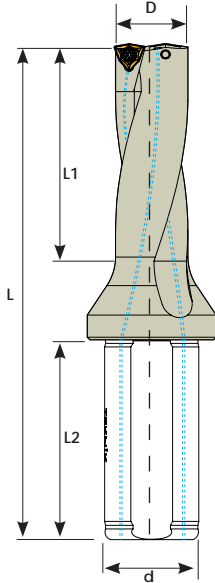
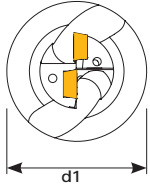

Sipariş Kodu	Ürün Kodu	Ölçüler (mm)								Uç	Fiyat
		D	d	d1	L	L1	L2	kg			
U143	16 D3 WCM_03	16	25	34	124	48	56	0,307		₺2.060	
U143-1	16,5 D3 WCM_03	16,5	25	34	124	48	56	0,304		₺2.060	
U144	17 D3 WCM_03	17	25	34	127	51	56	0,320	WCM_0302	₺2.060	
U145	17,5 D3 WCM_03	17,5	25	34	127	51	56	0,336	KRLY	₺2.060	
U146	18 D3 WCM_03	18	25	34	131	54	56	0,332		₺2.060	
U147	18,5 D3 WCM_03	18,5	25	34	131	54	56	0,348		₺2.060	
U148	19 D3 WCM_03	19	25	34	134	57	56	0,338		₺2.060	
U149	19,5 D3 WCM_03	19,5	25	34	134	57	56	0,340		₺2.060	
U150	20 D3 WCM_04	20	25	34	139	60	56	0,344		₺2.134	
U151	20,5 D3 WCM_04	20,5	25	34	139	60	56	0,360		₺2.134	
U152	21 D3 WCM_04	21	25	34	142	63	56	0,376	WCM_0402	₺2.134	
U153	21,5 D3 WCM_04	21,5	25	34	142	63	56	0,281	KRLY	₺2.134	
U154	22 D3 WCM_04	22	25	34	145	66	56	0,385		₺2.134	
U155	22,5 D3 WCM_04	22,5	25	34	145	66	56	0,394		₺2.134	
U156	23 D3 WCM_04	23	25	34	150	69	56	0,400		₺2.134	
U157	23,5 D3 WCM_04	23,5	25	34	150	69	56	0,413		₺2.134	
U158	24 D3 WCM_05	24	25	34	154	72	56	0,446		₺2.231	
U159	24,5 D3 WCM_05	24,5	25	34	154	72	56	0,453		₺2.231	
U160	25 D3 WCM_05	25	25	34	158	75	56	0,467	WCM_0503	₺2.231	
U161	25,5 D3 WCM_05	25,5	25	34	158	75	56	0,490	KRLY	₺2.231	
U162	26 D3 WCM_05	26	25	34	161	78	56	0,494		₺2.231	
U163	26,5 D3 WCM_05	26,5	25	34	161	78	56	0,497		₺2.231	
U164	27 D3 WCM_05	27	25	34	164	81	56	0,512		₺2.231	
U165	27,5 D3 WCM_05	27,5	25	34	164	81	56	0,520		₺2.231	
U166	28 D3 WCM_05	28	25	39	168	84	56	0,576		₺2.231	
U167	28,5 D3 WCM_05	28,5	25	39	168	84	56	0,584		₺2.231	
U168	29 D3 WCM_05	29	25	39	171	87	56	0,617		₺2.231	
U169	29,5 D3 WCM_05	29,5	25	39	171	87	56	0,610		₺2.231	
Kod											
U143-U157		TC060 M2,5x5,5									
U158-U169		TC065 M3x7 M3,5x9						T8			

KRLY Ucuna Uygunur.

D3 WCM_

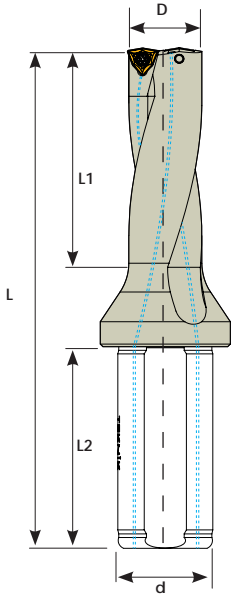
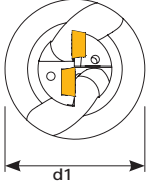

Sipariş Kodu	Ürün Kodu	Ölçüler (mm)								Uç	Fiyat
		D	d	d1	L	L1	L2				
U170	30 D3 WCM_06	30	32	44	181	90	58	0,847		₺2.281	
U171	30,5 D3 W_M_06	30,5	32	44	181	90	58	0,844		₺2.281	
U172	31 D3 WCM_06	31	32	44	185	93	58	0,872	WCM_06T3	₺2.281	
U174	32 D3 WCM_06	32	32	44	188	96	58	0,921	KRLY	₺2.281	
U176	33 D3 WCM_06	33	32	44	192	99	58	0,973		₺2.281	
U178	34 D3 WCM_06	34	32	44	195	102	58	1,037		₺2.281	
U179	35 D3 WCM_06	35	32	44	199	105	58	1,082		₺2.358	
U180	36 D3 WCM_06	36	32	44	203	108	58	1,092		₺2.358	
U181	37 D3 WCM_06	37	32	44	207	111	58	1,141		₺2.358	
U182	38 D3 WCM_06	38	32	44	211	114	58	1,188		₺2.358	
U183	39 D3 WCM_06	39	32	44	214	117	58	1,244		₺2.358	
U184	40 D3 WCM_06	40	32	44	218	120	58	1,295		₺2.580	
U186	41 D3 WCM_06	41	32	49	232	123	58	1,465		₺2.580	
U188	42 D3 WCM_06	42	32	49	235	126	58	1,646		₺2.580	
U190	43 D3 WCM_06	43	32	54	239	129	58	1,726		₺2.580	
U192	44 D3 WCM_06	44	32	54	242	132	58	1,916		₺2.580	
U194	45 D3 WCM_06	45	40	59	247	135	68	2,238		₺2.580	
U196	46 D3 WCM_08	46	40	59	251	138	68	2,276		₺2.678	
U198	47 D3 WCM_08	47	40	59	254	141	68	1,919		₺2.678	
U200	48 D3 WCM_08	48	40	59	258	144	68	2,486		₺2.678	
U201	49 D3 WCM_08	49	40	59	261	147	68	5,562		₺3.224	
U202	50 D3 WCM_08	50	40	59	265	150	68	2,725	WCM_0804	₺3.224	
U203	51 D3 WCM_08	51	40	59	268	153	68	2,537	KRLY	₺3.593	
U205	52 D3 WCM_08	52	40	59	271	156	68	2,655		₺3.593	
U207	53 D3 WCM_08	53	40	59	274	159	68	2,740		₺3.918	
U209	54 D3 WCM_08	54	40	59	277	162	68	3,210		₺3.918	
U211	55 D3 WCM_08	55	40	59	280	165	68	3,237		₺4.019	

Kod

U170-U194
U196-U211

TC067 M3,5x8,5
TC074 M4x10

T15



KRLY Ucuna Uygundur.

D4 WCM_

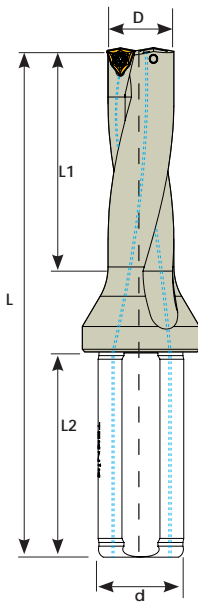
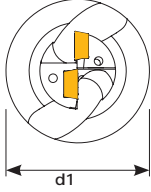

Sipariş Kodu	Ürün Kodu	Ölçüler (mm)							Uç	Fiyat
		D	d	d1	L	L1	L2	kg		
U600	16 D4 WCM_03	16	25	34	140	64	56	0,324		₺2.655
U602	17 D4 WCM_03	17	25	34	144	68	56	0,328	WCM_0302	₺2.655
U604	18 D4 WCM_03	18	25	34	149	72	56	0,355	KRLY	₺2.655
U606	19 D4 WCM_03	19	25	34	153	76	56	0,357		₺2.655
U608	20 D4 WCM_04	20	25	34	159	80	56	0,383	WCM_0402	₺2.775
U610	21 D4 WCM_04	21	25	34	163	84	56	0,411	KRLY	₺2.775
U612	22 D4 WCM_04	22	25	34	167	88	56	0,430		₺2.775
U614	23 D4 WCM_04	23	25	34	173	92	56	0,464		₺2.775
U616	24 D4 WCM_05	24	25	34	178	96	56	0,425		₺2.901
U618	25 D4 WCM_05	25	25	34	183	100	56	0,526		₺2.901
U620	26 D4 WCM_05	26	25	34	187	104	56	0,542	WCM_0503	₺2.901
U622	27 D4 WCM_05	27	25	34	191	108	56	0,580	KRLY	₺2.901
U624	28 D4 WCM_05	28	25	39	196	112	56	0,662		₺2.901
U626	29 D4 WCM_05	29	25	39	200	116	56	0,680		₺2.901
U628	30 D4 WCM_06	30	32	44	211	120	58	0,912		₺3.000
U631	31 D4 WCM_06	31	32	44	216	124	58	0,981		₺3.000
U632	32 D4 WCM_06	32	32	44	220	128	58	1,046		₺3.000
U633	33 D4 WCM_06	33	32	44	225	132	58	1,102		₺3.000
U634	34 D4 WCM_06	34	32	44	229	136	58	1,111	WCM_06T3	₺3.071
U635	35 D4 WCM_06	35	32	44	234	140	58	1,187	KRLY	₺3.071
U636	36 D4 WCM_06	36	32	44	239	144	58	1,172		₺3.071
U637	37 D4 WCM_06	37	32	44	244	148	58	1,260		₺3.071
U638	38 D4 WCM_06	38	32	44	249	152	58	1,430		₺3.224
U639	39 D4 WCM_06	39	32	44	253	156	58	1,380		₺3.224
U640	40 D4 WCM_06	40	32	44	258	160	58	1,460		₺3.224

Kod

U600-U614

TC060 M2,5x5,5

T8

U616-U626

TC065 M3x7

U628-640

TC067 M3,5x8,5

T15



KRLY Ucuna Uygunudur.

D5 WCM_

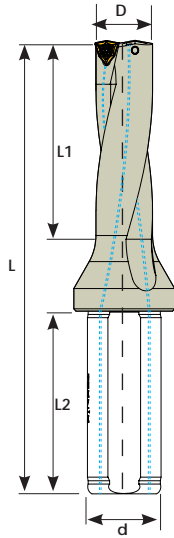
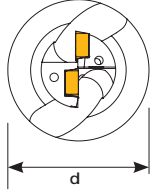

Sipariş Kodu	Ürün Kodu	Ölçüler (mm)							Uç	Fiyat
		D	d	d1	L	L1	L2			
U776	16 D5 WCM_03	16	25	34	156	80	56	0,378		₺3.126
U777	17 D5 WCM_03	17	25	34	161	85	56	0,468	WCM_0302	₺3.126
U778	18 D5 WCM_03	18	25	34	167	90	56	0,471	KRLY	₺3.126
U779	19 D5 WCM_03	19	25	34	172	95	56	0,397		₺3.126
U780	20 D5 WCM_04	20	25	34	179	100	56	0,421		₺3.126
U781	21 D5 WCM_04	21	25	34	184	105	56	0,451	WCM_0402	₺3.126
U782	22 D5 WCM_04	22	25	34	190	110	56	0,470	KRLY	₺3.126
U783	23 D5 WCM_04	23	25	34	196	115	56	0,504		₺3.126
U784	24 D5 WCM_05	24	25	34	202	120	56	0,465		₺3.373
U785	25 D5 WCM_05	25	25	34	208	125	56	0,678	WCM_0503	₺3.373
U786	26 D5 WCM_05	26	25	34	213	130	56	0,620	KRLY	₺3.373
U787	27 D5 WCM_05	27	25	34	218	135	56	0,620		₺3.373
U788	28 D5 WCM_05	28	25	39	224	140	56	0,742		₺3.373
U789	29 D5 WCM_05	29	25	39	229	145	56	0,760		₺3.373
U790	30 D5 WCM_06	30	32	44	241	150	58	0,992		₺3.520
U791	31 D5 WCM_06	31	32	44	246	155	58	1,061		₺3.520
U792	32 D5 WCM_06	32	32	44	252	160	58	1,126	WCM_06T3	₺3.520
U793	33 D5 WCM_06	33	32	44	258	165	58	1,182	KRLY	₺3.520
U794	34 D5 WCM_06	34	32	44	263	170	58	1,191		₺3.669
U795	35 D5 WCM_06	35	32	44	269	175	58	1,227		₺3.669
U796	36 D5 WCM_06	36	32	44	275	180	58	1,172		₺3.669
U797	37 D5 WCM_06	37	32	44	281	185	58	1,300		₺3.669
U798	38 D5 WCM_06	38	32	44	287	190	58	1,480		₺4.064
U799	39 D5 WCM_06	39	32	44	292	195	58	1,520		₺4.064
U800	40 D5 WCM_06	40	32	44	298	200	58	1,490		₺4.064

Kod

U776-U783

TC060 M2,5x5,5

U784-U789

TC065 M3x7 M3,5x9

U790-U800

TC067 M3,5x8,5

T8

T15

KRLY Ucuna Uygundur.

D2 SPMG

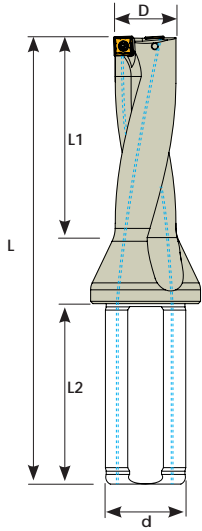
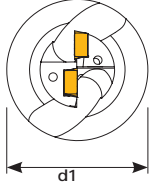



Sipariş Kodu	Ürün Kodu	Ölçüler (mm)								Uç	Fiyat
		D	d	d1	L	L1	L2	kg			
U913	13 D2 SPMG 05	13	20	25	94	26	50	0,145	SPMG 0502	₺1.861	
U914	14 D2 SPMG 05	14	20	25	96	28	50	0,152	TGTC YG-1	₺1.861	
U915	15 D2 SPMG 05	15	20	25	99	30	50	0,157		₺1.861	
U916	16 D2 SPMG 06	16	25	34	108	32	56	0,275		₺1.861	
U917	17 D2 SPMG 06	17	25	34	110	34	56	0,291		₺1.861	
U918	18 D2 SPMG 06	18	25	34	113	36	56	0,302	SPMG 0602	₺1.861	
U919	19 D2 SPMG 06	19	25	34	115	38	56	0,329	TGTC YG-1	₺1.861	
U920	20 D2 SPMG 06	20	25	34	119	40	56	0,334		₺2.009	
U921	21 D2 SPMG 06	21	25	34	121	42	56	0,338		₺2.009	
U922	22 D2 SPMG 07	22	25	34	123	44	56	0,340		₺2.009	
U923	23 D2 SPMG 07	23	25	34	127	46	56	0,354	SPMG 07T3	₺2.009	
U924	24 D2 SPMG 07	24	25	34	130	48	56	0,382	TGTC YG-1	₺2.109	
U925	25 D2 SPMG 07	25	25	34	133	50	56	0,450		₺2.109	
U926	26 D2 SPMG 07	26	25	34	135	52	56	0,423		₺2.109	
U927	27 D2 SPMG 07	27	25	34	137	54	56	0,435		₺2.109	
U928	28 D2 SPMG 09	28	25	39	140	56	56	0,500		₺2.109	
U929	29 D2 SPMG 09	29	25	39	142	58	56	0,535	SPMG 0904	₺2.109	
U930	30 D2 SPMG 09	30	32	44	151	60	58	0,735	TGTC YG-1	₺2.231	
U931	31 D2 SPMG 09	31	32	44	154	62	58	0,766		₺2.231	
U932	32 D2 SPMG 09	32	32	44	156	64	58	0,781		₺2.231	
U933	33 D2 SPMG 09	33	32	44	159	66	58	0,815		₺2.231	
U934	34 D2 SPMG 11	34	32	44	161	68	58	0,784		₺2.231	
U935	35 D2 SPMG 11	35	32	44	164	70	58	0,845	SPMG 1104	₺2.333	
U936	36 D2 SPMG 11	36	32	44	167	72	58	0,893	TGTC YG-1	₺2.333	
U937	37 D2 SPMG 11	37	32	44	170	74	58	0,931		₺2.333	
U938	38 D2 SPMG 11	38	32	44	173	76	58	0,992		₺2.333	
U939	39 D2 SPMG 11	39	32	44	175	78	58	1,007		₺2.333	
U940	40 D2 SPMG 11	40	32	44	178	80	58	1,020		₺2.333	

Kod		
U913-U915	TC058 M2x4,2	T6
U916-U921	TC059 M2,2x5	T7
U922-U927	TC063 M2,5x7	T8
U928-U933	TC067 M3,5x8,5	T15
U934-U940	TC074 M4x10	

TGTC-YG-1 Ucuna Uygunudur.

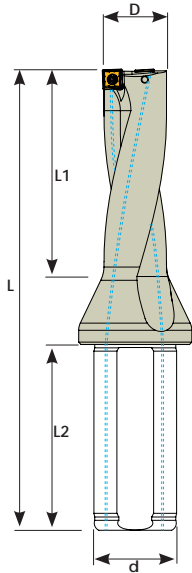
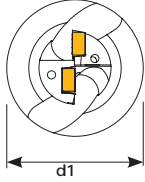
D3 SPMG



Sipariş Kodu	Ürün Kodu	Ölçüler (mm)								Uç	Fiyat
		D	d	d1	L	L1	L2				
U812	12,5 D3 SPMG 05	12,5	20	12	106	38	50	0,158		₺2.060	
U813	13 D3 SPMG 05	13	20	25	107	39	50	0,164	SPMG 0502	₺2.060	
U813-1	13,5 D3 SPMG 05	13,5	20	25	107	39	50	0,167	TGTC	₺2.060	
U814	14 D3 SPMG 05	14	20	25	110	42	50	0,170	YG-1	₺2.060	
U814-1	14,5 D3 SPMG 05	14,5	20	25	110	42	50	0,170		₺2.060	
U815	15 D3 SPMG 05	15	20	25	114	45	50	0,175		₺2.060	
U815-1	15,5 D3 SPMG 05	15,5	20	25	114	45	50	0,175		₺2.060	
U816	16 D3 SPMG 06	16	25	34	124	48	56	0,302		₺2.060	
U816-1	16,5 D3 SPMG 06	16,5	25	34	124	48	56	0,302		₺2.060	
U817	17 D3 SPMG 06	17	25	34	127	51	56	0,318		₺2.060	
U817-1	17,5 D3 SPMG 06	17,5	25	34	127	51	56	0,318		₺2.060	
U818	18 D3 SPMG 06	18	25	34	131	54	56	0,327	SPMG 0602	₺2.060	
U818-1	18,5 D3 SPMG 06	18,5	25	34	131	54	56	0,327	TGTC	₺2.060	
U819	19 D3 SPMG 06	19	25	34	134	57	56	0,330	YG-1	₺2.060	
U819-1	19,5 D3 SPMG 06	19,5	25	34	134	57	56	0,330		₺2.060	
U820	20 D3 SPMG 06	20	25	34	139	60	56	0,347		₺2.134	
U820-1	20,5 D3 SPMG 06	20,5	25	34	139	60	56	0,350		₺2.134	
U821	21 D3 SPMG 06	21	25	34	142	63	56	0,377		₺2.134	
U821-1	21,5 D3 SPMG 06	21,5	25	34	142	63	56	0,377		₺2.134	
U822	22 D3 SPMG 07	22	25	34	145	66	56	0,375		₺2.134	
U822-1	22,5 D3 SPMG 07	22,5	25	34	145	66	56	0,375		₺2.134	
U823	23 D3 SPMG 07	23	25	34	150	69	56	0,407		₺2.134	
U823-1	23,5 D3 SPMG 07	23,5	25	34	150	69	56	0,412		₺2.134	
U824	24 D3 SPMG 07	24	25	34	154	72	56	0,446	SPMG 07T3	₺2.231	
U824-1	24,5 D3 SPMG 07	24,5	25	34	154	72	56	0,452	TGTC	₺2.231	
U825	25 D3 SPMG 07	25	25	34	158	75	56	0,460	YG-1	₺2.231	
U825-1	25,5 D3 SPMG 07	25,5	25	34	158	75	56	0,467		₺2.231	
U826	26 D3 SPMG 07	26	25	34	161	78	56	0,481		₺2.231	
U826-1	26,5 D3 SPMG 07	26,5	25	34	161	78	56	0,487		₺2.231	
U827	27 D3 SPMG 07	27	25	34	164	81	56	0,504		₺2.231	
U827-1	27,5 D3 SPMG 07	27,5	25	34	164	81	56	0,511		₺2.231	
U828	28 D3 SPMG 09	28	25	39	168	84	56	0,562		₺2.231	
U828-1	28,5 D3 SPMG 09	28,5	25	39	168	84	56	0,572		₺2.231	
U829	29 D3 SPMG 09	29	25	39	171	87	56	0,580	SPMG 0904	₺2.231	
U829-1	29,5 D3 SPMG 09	29,5	25	39	171	87	56	0,585	TGTC	₺2.231	
U830	30 D3 SPMG 09	30	32	44	181	90	58	0,823	YG-1	₺2.281	
U831	31 D3 SPMG 09	31	32	44	185	93	58	0,884		₺2.281	
U832	32 D3 SPMG 09	32	32	44	188	96	58	0,923		₺2.281	
U833	33 D3 SPMG 09	33	32	44	192	99	58	0,920		₺2.281	
U834	34 D3 SPMG 11	34	32	44	195	102	58	0,943		₺2.281	
U835	35 D3 SPMG 11	35	32	44	199	105	58	0,960	SPMG 1104	₺2.358	
U836	36 D3 SPMG 11	36	32	44	203	108	58	1,043	TGTC	₺2.358	
U837	37 D3 SPMG 11	37	32	44	207	111	58	1,057	YG-1	₺2.358	
U838	38 D3 SPMG 11	38	32	44	211	114	58	1,062		₺2.358	
U839	39 D3 SPMG 11	39	32	44	214	117	58	1,155		₺2.358	
U840	40 D3 SPMG 11	40	32	44	218	120	58	1,238		₺2.580	

Kod

U812-U815-1	TC058 M2x4,2	T6
U816-U821-1	TC059 M2,2x5	T7
U822-U827-1	TC063 M2,5x7	T8
U828-U833	TC067 M3,5x8,5	T15
U834-U840	TC074 M4x10	



D4 SPMG

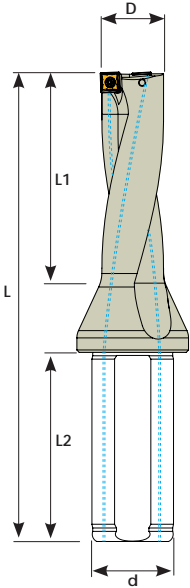
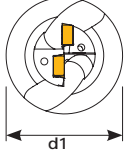

Sipariş Kodu	Ürün Kodu	Ölçüler (mm)							Uç	Fiyat
		D	d	d1	L	L1	L2			
U713	13 D4 SPMG 05	13	20	25	120	52	50	0,170	SPMG 0502	₺2.605
U714	14 D4 SPMG 05	14	20	25	124	56	50	0,180	TGTC	₺2.605
U715	15 D4 SPMG 05	15	20	25	129	60	50	0,190	YG-1	₺2.605
U716	16 D4 SPMG 06	16	25	34	140	64	56	0,330		₺2.655
U717	17 D4 SPMG 06	17	25	34	144	68	56	0,333		₺2.655
U718	18 D4 SPMG 06	18	25	34	149	72	56	0,350	SPMG 0602	₺2.655
U719	19 D4 SPMG 06	19	25	34	153	76	56	0,357	TGTC	₺2.655
U720	20 D4 SPMG 06	20	25	34	159	80	56	0,383	YG-1	₺2.775
U721	21 D4 SPMG 06	21	25	34	163	84	56	0,387		₺2.775
U722	22 D4 SPMG 07	22	25	34	167	88	56	0,417		₺2.775
U723	23 D4 SPMG 07	23	25	34	173	92	56	0,448	SPMG 07T3	₺2.901
U724	24 D4 SPMG 07	24	25	34	178	96	56	0,460	TGTC	₺2.901
U725	25 D4 SPMG 07	25	25	34	183	100	56	0,505	YG-1	₺2.901
U726	26 D4 SPMG 07	26	25	34	187	104	56	0,539		₺2.901
U727	27 D4 SPMG 07	27	25	34	191	108	56	0,561		₺2.901
U728	28 D4 SPMG 09	28	25	39	196	112	56	0,642		₺2.901
U729	29 D4 SPMG 09	29	25	39	200	116	56	0,646	SPMG 0904	₺2.901
U730	30 D4 SPMG 09	30	32	44	211	120	58	0,930	TGTC	₺3.000
U731	31 D4 SPMG 09	31	32	44	216	124	58	0,974	YG-1	₺3.000
U732	32 D4 SPMG 09	32	32	44	220	128	58	1,014		₺3.000
U733	33 D4 SPMG 09	33	32	44	225	132	58	1,050		₺3.000
U734	34 D4 SPMG 11	34	32	44	229	136	58	1,040		₺3.071
U735	35 D4 SPMG 11	35	32	44	234	140	58	1,155	SPMG 1104	₺3.071
U736	36 D4 SPMG 11	36	32	44	239	144	58	1,185	TGTC	₺3.071
U737	37 D4 SPMG 11	37	32	44	244	148	58	1,232	YG-1	₺3.071
U738	38 D4 SPMG 11	38	32	44	249	152	58	1,320		₺3.224
U739	39 D4 SPMG 11	39	32	44	253	156	58	1,356		₺3.224
U740	40 D4 SPMG 11	40	32	44	258	160	58	1,421		₺3.224

Kod

U713-U715	TC058 M2x4,2	T6
U716-U721	TC059 M2,2x5	T7
U722-U727	TC063 M2,5x7	T8
U728-U733	TC067 M3,5x8,5	T15
U734-U740	TC074 M4x10	

TGTC insert. / Kompatible für TGTC WP

D3 SPMT

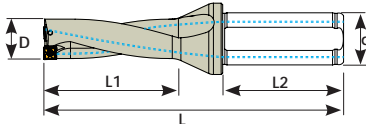
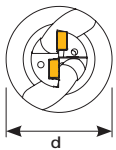

Sipariş Kodu	Ürün Kodu	Ölçüler (mm)							Uç	Fiyat
		D	d	d1	L	L1	L2			
U004	13 D3 SPMT 05	13	20	25	107	39	50	0,154	SPMT 0502	₺2.060
U006	14 D3 SPMT 05	14	20	25	110	42	50	0,158	KRLY.	₺2.060
U008	15 D3 SPMT 05	15	20	25	114	45	50	0,168		₺2.060
U010	16 D3 SPMT 06	16	25	34	124	48	56	0,308		₺2.060
U012	17 D3 SPMT 06	17	25	34	127	51	56	0,313	SPMT 0602	₺2.060
U014	18 D3 SPMT 06	18	25	34	131	54	56	0,327	KRLY.	₺2.060
U016	19 D3 SPMT 06	19	25	34	134	57	56	0,350		₺2.060
U018	20 D3 SPMT 07	20	25	34	139	60	56	0,353	SPMT 0702	₺2.134
U020	21 D3 SPMT 07	21	25	34	142	63	56	0,395	KRLY.	₺2.134

Kod

U004-U008	TC058 M2x4,2	T6
U010-U016	TC059 M2,2x5	T7
U018-U022	TC063 M2,5x7	T8

KRLY Ucuna Uygundur.

D3 SOMT

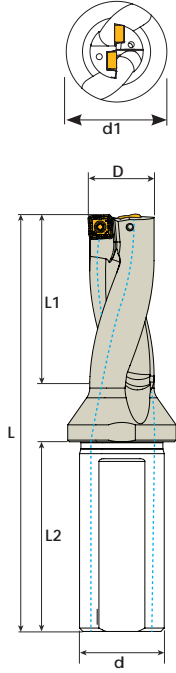

Sipariş Kodu	Ürün Kodu	Ölçüler (mm)								Uç	Fiyat
		D	d	d1	L	L1	L2	kg			
U300	13 D3 SOMT 05	13	20	25	111	39	50	0,157		₺2.060	
U302	14 D3 SOMT 05	14	20	25	114	42	50	0,165	SOMT 0502	₺2.060	
U303	14,5 D3 SOMT 05	14,5	20	25	114	42	50	0,170	TGTC	₺2.060	
U304	15 D3 SOMT 05	15	20	25	117	45	50	0,175		₺2.060	
U305	15,5 D3 SOMT 05	15,5	20	25	117	45	50	0,175		₺2.060	
U306	16 D3 SOMT 05	16	25	34	126	48	56	0,302		₺2.060	
U307	16,5 D3 SOMT 06	16,5	25	34	126	48	56	0,302	SOMT 0602	₺2.060	
U308	17 D3 SOMT 06	17	25	34	129	51	56	0,318	TGTC	₺2.060	
U309	17,5 D3 SOMT 06	17,5	25	34	129	51	56	0,318		₺2.060	
U310	18 D3 SOMT 06	18	25	34	132	54	56	0,327		₺2.060	
U311	18,5 D3 SOMT 06	18,5	25	34	132	54	56	0,327		₺2.060	
U312	19 D3 SOMT 06	19	25	34	135	57	56	0,330		₺2.060	
U313	19,5 D3 SOMT 07	19,5	25	34	135	57	56	0,330	SOMT 07T3	₺2.134	
U314	20 D3 SOMT 07	20	25	34	138	60	56	0,347	TGTC	₺2.134	
U315	20,5 D3 SOMT 07	20,5	25	34	138	60	56	0,350		₺2.134	
U316	21 D3 SOMT 07	21	25	34	141	63	56	0,377		₺2.134	
U318	22 D3 SOMT 08	22	25	34	144	66	56	0,375		₺2.134	
U319	22,5 D3 SOMT 08	22,5	25	34	144	66	56	0,375	SOMT 08T3	₺2.134	
U320	23 D3 SOMT 08	23	25	34	147	69	56	0,407	TGTC	₺2.134	
U321	23,5 D3 SOMT 08	23,5	25	34	147	69	56	0,412		₺2.231	
U322	24 D3 SOMT 08	24	25	34	150	72	56	0,446		₺2.231	
U323	24,5 D3 SOMT 08	24,5	25	34	150	72	56	0,452		₺2.231	
U324	25 D3 SOMT 08	25	25	34	153	75	56	0,460		₺2.231	

Kod	TC	T
U300-U306	TC058 M2x4,2	T6
U307-U318	TC059 M2,2x5	T7
U319-U324	TC063 M2,5x7	T8

TGTC Ucuna Uygundur.

D4 SOMT

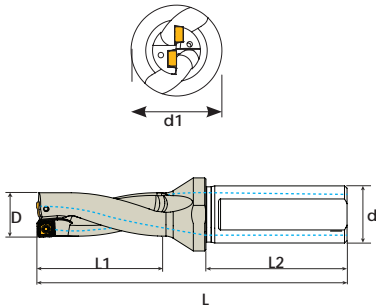

Sipariş Kodu	Ürün Kodu	Ölçüler (mm)								Uç	Fiyat
		D	d	d1	L	L1	L2	kg			
U402	14 D4 SOMT 05	14	20	25	128	56	50	0,170	SOMT 0502	₺2.605	
U403	14,5 D4 SOMT 05	14,5	20	25	128	56	50	0,175	TGTC	₺2.605	
U406	16 D4 SOMT 05	16	25	34	142	64	56	0,322		₺2.655	
U408	17 D4 SOMT 06	17	25	34	146	68	56	0,338	SOMT 0602	₺2.655	
U409	17,5 D4 SOMT 06	17,5	25	34	146	68	56	0,348	TGTC	₺2.655	
U410	18 D4 SOMT 06	18	25	34	150	72	56	0,347		₺2.655	
U412	19 D4 SOMT 06	19	25	34	154	76	56	0,350		₺2.655	
U414	20 D4 SOMT 07	20	25	34	158	8	56	0,387	SOMT 07T3	₺2.775	
U416	21 D4 SOMT 07	21	25	34	162	84	56	0,417	TGTC	₺2.775	
U418	22 D4 SOMT 07	22	25	34	166	88	56	0,425		₺2.775	
U420	24 D4 SOMT 08	24	25	34	174	96	56	0,486	SOMT 08T3	₺2.901	
U422	25 D4 SOMT 08	25	25	34	178	100	56	0,498	TGTC	₺2.901	

Kod	TC	T
U402-U406	TC058 M2x4,2	T6
U408-U418	TC059 M2,2x5	T7
U420-U422	TC063 M2,5x7	T8

TGTC Ucuna Uygundur.

D2-D3 XCMT-QCMT

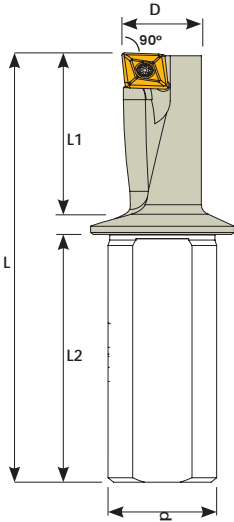
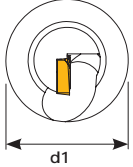

Sipariş Kodu	Ürün Kodu	Ölçüler (mm)							Uç	Fiyat
		D	d	d1	L	L1	L2			
U030	10 D2,25 QC-- 050204	10	12	16	74,5	22,5	42	0,062	QC-- 050204 KRLY	₺1.513
U032	12 D2,25 QC-- 060204	12	16	20	85	27	45	0,100	QC-- 060204 KRLY	₺1.513
U034	14 D2,25 QC-- 070304	14	16	20	90	31,5	45	0,111	QC-- 070304 KRLY	₺1.586
U036	16 D2,25 QC-- 080304	16	20	25	100	36	50	0,191	QC-- 080304 KRLY	₺1.586
U040	20 D2,25 QC-- 10T304	20	25	31	116	45	56	0,330	QC-- 10T304 KRLY	₺1.663
U042	25 D2,25 QC-- 130404	25	32	39	135	56,5	60	0,600	QC-- 130404 KRLY	₺1.786
U038	18 D2,25 XC-- 09T304	18	25	31	112	40,5	56	0,356	XCMT 09T304 ISCR	₺1.663

Kod			
U030	TC058 M2x4,2	T6	QC-- 050204
U032	TC059 M2,2x5	T7	QC-- 060204
U034	TC060 M2,5x5,5	T8	QC-- 070304
U036	TC065 M3x7	T8	QC-- 080304
U040	TC067 M3,5x8,5	T15	QC-- 10T304
U042	TC080 M4,5x11	T15	QC-- 130404
U038	TC065 M3x7	T8	XCMT 09T304

KRLY Ucuna Uygunur. (QC--)(QX--) - ISCR Ucuna Uygunur.(XCMT) ,(XCMT)

Sipariş Kodu	Ürün Kodu	Ölçüler (mm)							Uç	Fiyat
		D	d	d1	L	L1	L2			
U08	8 D2 XC-- 040104	8	12	16	68	18	42	0,056	XCMT 0401 TGTC	₺1.513
U12	10 D3 XC-- 050204	10	16	25	90	30	45	0,109	XCMT 0502	₺1.513
U14	10,5 D3 XC-- 050204	10,5	16	25	90	31	45	0,111	TGTC	₺1.513
U18	11,5 D3 XC-- 060204	11,5	16	25	92	35	45	0,113	XCMT 0602	₺1.513
U20	12 D3 XC-- 060204	12	16	25	94	36	45	0,114	TGTC	₺1.513

Kod			
U08	TC058 M2x4,2	T6	XCMT 040104
U12 - U14	TC058 M2x4,5	T6	XCMT 050204
U18 - U20	TC059 M2,2x5	T7	XCMT 060204

TGTC Ucuna Uygunur.

Alüminyum

Sipariş Kodu	Ürün Kodu	Ölçüler (mm)							Uç	Fiyat
		D	d	d1	L	L1	L2			
U32	10,5 D3 XC-- 050204	10,5	16	25	90	31	45	0,114	XCGT 050204	₺1.513
U34	11 D3 XC-- 050204	11	16	25	92	33	45	0,112	TGTC	₺1.513
U36	11,5 D3 XC-- 060204	11,5	16	25	92	35	45	0,112	XCGT 060204 TGTC	₺1.513

Kod			
U32 - U34	TC058 M2x4,5	T6	XCGT 050204
U36	TC059 M2,2x5	T7	XCGT 060204

TGTC Ucuna Uygunur.

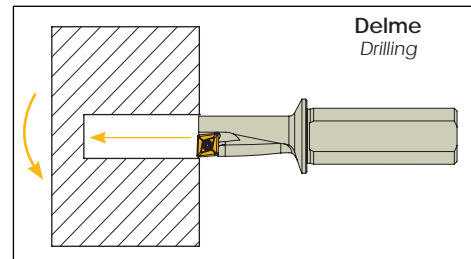
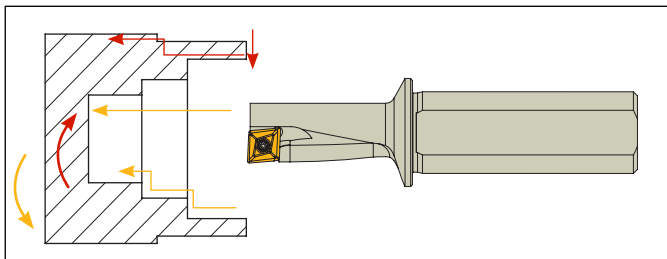

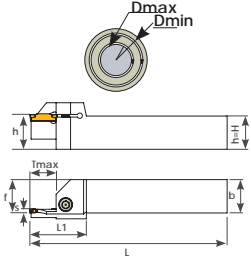
KRLY-R

Sipariş Kodu	Ürün Kodu	Ölçüler (mm)											Uç	Fiyat
		Dmin	Dmax	S	Tmax	f	b	h	L	L1				
D780	2525 3C-R (50-60)	50	60	3	17	25	25	25	150	40	0,741		₺1.388	
D782	2525 3C-R (60-80)	60	80	3	17	25	25	25	150	40	0,717	MGM 300	₺1.388	
D784	2525 3C-R (80-110)	80	110	3	17	25	25	25	150	40	0,720	KRLY.	₺1.388	
D785	2525 3C-R (110-150)	110	150	3	17	25	25	25	150	40	0,730		₺1.388	
D786	2525 4C-R (50-60)	50	60	4	20	25	25	25	150	45	0,704		₺1.388	
D788	2525 4C-R (60-80)	60	80	4	20	25	25	25	150	45	0,712	MGM 400	₺1.388	
D790	2525 4C-R (80-110)	80	110	4	20	25	25	25	150	45	0,701	KRLY.	₺1.388	
D791	2525 4C-R (110-150)	110	150	4	20	25	25	25	150	45	0,712		₺1.388	
D791-1	2525 4C (140-600)	140	600	4	25	25	25	25	150	49	0,667		₺1.388	
D792	2525 5C-R (50-80)	50	80	5	20	25	25	25	150	45	0,721		₺1.388	
D796	2525 5C-R (80-110)	80	110	5	20	25	25	25	150	45	0,716	MGM 500	₺1.388	
D798	2525 5C-R (110-150)	110	150	5	20	25	25	25	150	45	0,718	KRLY.	₺1.388	
D799-1	2525 5C-R (350-500)	350	500	5	20	25	25	25	150	45	0,713		₺1.388	
D799-2	2525 5C-R (140-600)	140	600	5	25	25	25	25	150	49	0,664		₺1.388	

TC134 M6x20

5 Allen

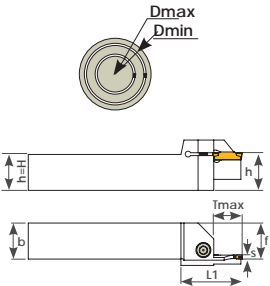

KRLY Ucuna Uygundur.

KRLY-L

Sipariş Kodu	Ürün Kodu	Ölçüler (mm)											Uç	Fiyat
		Dmin	Dmax	S	Tmax	f	b	h	L	L1				
D800	2525 3C-L (50-60)	50	60	3	17	25	25	25	150	40	0,741		₺1.388	
D802	2525 3C-L (60-80)	60	80	3	17	25	25	25	150	40	0,717	MGM 300	₺1.388	
D804	2525 3C-L (80-110)	80	110	3	17	25	25	25	150	40	0,720	KRLY	₺1.388	
D805	2525 3C-L (110-150)	110	150	3	17	25	25	25	150	40	0,730		₺1.388	
D806	2525 4C-L (50-60)	50	60	4	20	25	25	25	150	45	0,704		₺1.388	
D808	2525 4C-L (60-80)	60	80	4	20	25	25	25	150	45	0,712	MGM 400	₺1.388	
D810	2525 4C-L (80-110)	80	110	4	20	25	25	25	150	45	0,700	KRLY	₺1.388	
D811	2525 4C-L (110-150)	110	150	4	20	25	25	25	150	45	0,712		₺1.388	
D811-1	2525 4C-L (140-600)	140	600	4	25	25	25	25	150	49	0,667		₺1.388	
D812	2525 5C-L (50-80)	50	80	5	20	25	25	25	150	45	0,721		₺1.388	
D816	2525 5C-L (80-110)	80	110	5	20	25	25	25	150	45	0,716		₺1.388	
D818	2525 5C-L (110-150)	110	150	5	20	25	25	25	150	45	0,718	MGM 500	₺1.388	
D819	2525 5C-L (140-600)	140	600	5	25	25	25	25	150	49	0,664	KRLY	₺1.388	
D819-1	2525 5C-L (350-500)	350	500	5	20	25	25	25	150	45	0,713		₺1.388	

TC134 M6x20

5 Allen

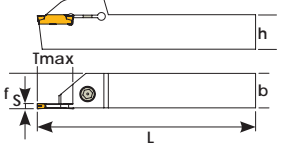
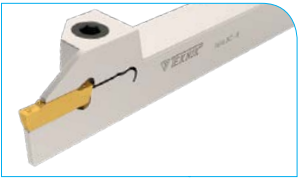

KRLY Ucuna Uygundur.

MGM/R

Sipariş Kodu	Ürün Kodu	Ölçüler (mm)							Uç	Fiyat
		h	b	S	Tmax	f	L			
D658	1212 2C-R MGM	12	12	2	16	12	125	0,162		₺870
D660	1616 2C-R MGM	16	16	2	16	16	125	0,250	MGM 200	₺920
D662	2020 2C-R MGM	20	20	2	16	20	125	0,404	KRLY	₺969
D664	2525 2C-R MGM	25	25	2	16	25	150	0,726		₺1.041
D666	3232 2C-R MGM	32	32	2	16	32	170	1,349		₺1.143
D667	1212 3C-R MGM	12	12	3	18	12	125	0,162		₺870
D668	1616 3C-R MGM	16	16	3	18	16	125	0,268	MGM 300	₺920
D670	2020 3C-R MGM	20	20	3	18	20	125	0,407	KRLY	₺969
D672	2525 3C-R MGM	25	25	3	18	25	150	0,727		₺1.041
D674	3232 3C-R MGM	32	32	3	18	32	170	1,280		₺1.143
D675	1616 4C-R MGM	16	16	4	18	16	125	0,273		₺920
D676	2020 4C-R MGM	20	20	4	18	20	125	0,408	MGM 400	₺969
D678	2525 4C-R MGM	25	25	4	18	25	150	0,727	KRLY	₺1.041
D680	3232 4C-R MGM	32	32	4	20	32	170	1,287		₺1.143
D682	2020 5C-R MGM	20	20	5	25	20	125	0,391	MGM 500	₺969
D684	2525 5C-R MGM	25	25	5	25	25	150	0,703	KRLY	₺1.041
D686	3232 5C-R MGM	32	32	5	25	32	170	1,268		₺1.143
D687	2525 6C-R MGM	25	25	6	27	25	150	0,745	MGM 600 KRLY	₺1.041

Kod

D658-D660,D667-D668,D675-D676



TC131 M5x16



4 Allen

D662,D670,D675-D676,D682

TC132 M5x20

D664-D666,D672-D674,D378,D680,D684,D687

TC134 M6x20

5 Allen



KRLY Ucuna Uygundur.

MGM /R

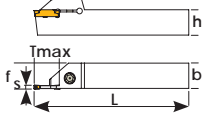

KRLY Ucuna Uygunur.

Sipariş Kodu	Ürün Kodu	Ölçüler (mm)							Uç	Fiyat
		h	b	S	Tmax	f	L			
D960	2525 3C-R MGM	25	25	3	25	25	150	0,727	MGM 300	₺1.365
D963	2525 3C-R MGM	25	25	3	40	25	170	0,722	KRLY	₺1.565
D961	2525 4C-R MGM	25	25	4	25	25	150	0,727	MGM 400	₺1.365
D964	2525 4C-R MGM	25	25	4	40	25	170	0,721	KRLY	₺1.565
D962	2525 5C-R MGM	25	25	5	40	25	170	0,745	MGM 500 KRLY	₺1.565



TC134 M6x20



5 Allen



MGM /L

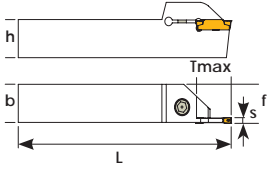

KRLY Ucuna Uygunur.

Sipariş Kodu	Ürün Kodu	Ölçüler (mm)							Uç	Fiyat
		h	b	S	Tmax	f	L			
D607	1212 2C-L MGM	12	12	2	16	12	125	0,161	MGM 200	₺870
D608	1616 2C-L MGM	16	16	2	16	16	125	0,250	KRLY	₺920
D610	2020 2C-L MGM	20	20	2	16	20	125	0,404		₺969
D611	2525 2C-L MGM	25	25	2	16	25	150	0,726		₺1.041
D612	1616 3C-L MGM	16	16	3	18	16	125	0,268	MGM 300	₺920
D614	2020 3C-L MGM	20	20	3	18	20	125	0,407	KRLY	₺969
D615	2525 3C-L MGM	25	25	3	18	25	150	0,750		₺1.041
D617	2020 4C-L MGM	20	20	4	18	20	125	0,407	MGM 400	₺969
D618	2525 4C-L MGM	25	25	4	18	25	150	0,727	KRLY	₺1.041
D620	2525 5C-L MGM	25	25	5	25	25	150	0,703	MGM 500 KRLY	₺1.041
D621	2525 6C-L MGM	25	25	5	27	25	150	0,745	MGM 600 KRLY	₺1.041

Kod

D607-D608,D612

D610,D614,D617

D615,D618-D621



TC131 M5x16

TC132 M5x20

TC134 M6x20



4 Allen

4 5 Allen



KGMN /R

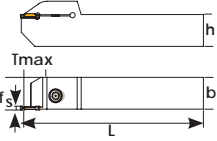
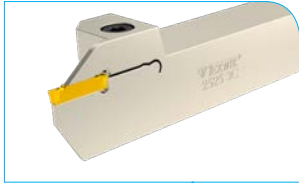

KRLY Ucuna Uygunur.

Sipariş Kodu	Ürün Kodu	Ölçüler (mm)							Uç	Fiyat
		h	b	S	Tmax	f	L			
D635	2020 2C-R KGMN	20	20	2	18	20	125	0,412	KGMN 200	₺969
D636	2525 2C-R KGMN	25	25	2	18	25	150	0,726	KRLY	₺1.041
D637	2020 3C-R KGMN	20	20	3	20	20	125	0,406	KGMN 300	₺969
D638	2525 3C-R KGMN	25	25	3	22	25	150	0,732	KRLY	₺1.041
D639	2020 4C-R KGMN	20	20	4	20	20	125	0,406	KGMN 400	₺969
D640	2525 4C-R KGMN	25	25	4	22	25	152	0,737	KRLY	₺1.041

Kod

D635,D637,D639

D636,D638,D640



TC132 M5x20

TC134 M6x20



4 Allen

5 Allen



KGMN

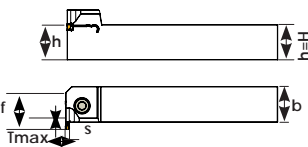

KRLY Ucuna Uygunur.

Sipariş Kodu	Ürün Kodu	Ölçüler (mm)							Uç	Fiyat
		h	b	S	Tmax	f	L			
D622	2020 2C KGMN	20	20	2	3,5	23,5	125	0,412	KGMN 200	₺969
D623	2525 2C KGMN	25	25	2	3,5	28,5	150	0,833	KRLY	₺1.041
D624	2020 3C KGMN	20	20	3	5	25	125	0,468	KGMN 300	₺969
D625	2525 3C KGMN	25	25	3	5	30	150	0,837	KRLY	₺1.041
D626	2020 4C KGMN	20	20	4	5	25	125	0,463	KGMN 400	₺969
D627	2525 4C KGMN	25	25	4	5	30	150	0,464	KRLY	₺1.041

Kod

D622,D624,D626

D623,D625,D627



TC132 M5x20

TC134 M6x20



4 Allen





5 Allen

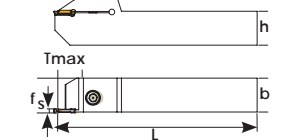

GRP/R





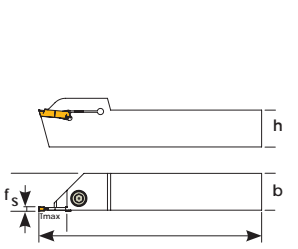
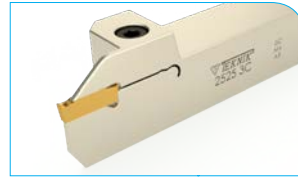

ISCR Ucuna Uygundur.

Sipariş Kodu	Ürün Kodu	Ölçüler (mm)							Uç	Fiyat
		h	b	S	Tmax	f	L			
D773	2020 3C-R GRP	20	20	3	18	20	125	0,409	GRP 3C	₺969
D769	2525 3C-R GRP	25	25	3	18	25	150	0,755	ISCR	₺1.041
D770	2525 4C-R GRP	25	25	4	20	25	150	0,747	GRP 4C	₺1.041
D772	3232 4C-R GRP	32	32	4	18	32	170	1,285	ISCR	₺1.143
D771	2525 5C-R GRP	25	25	5	24	25	150	0,739	GRP 5C	₺1.041
D774	3232 5C-R GRP	32	32	5	24	32	170	1,264	ISCR	₺1.143
Kod										
D773		TC132 M5x20			4 Allen					
D770-D774		TC134 M6x20			5 Allen					

ISCR/R





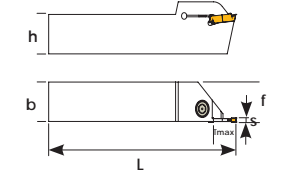

ISCR Ucuna Uygundur.

Sipariş Kodu	Ürün Kodu	Ölçüler (mm)							Uç	Fiyat
		h	b	S	Tmax	f	L			
D750	1212 2C-R DGN	12	12	2	16	12	125	0,158		₺870
D752	1616 2C-R DGN	16	16	2	16	16	125	0,260	DGN 2C	₺920
D754	2020 2C-R DGN	20	20	2	18	20	125	0,398	ISCR	₺969
D756	2525 2C-R DGN	25	25	2	19	25	150	0,712		₺1.041
D758	1212 3C-R DGN	12	12	3	16	12	125	0,160		₺870
D760	1616 3C-R DGN	16	16	3	19	16	125	0,253	DGN 3C	₺920
D762	2020 3C-R DGN	20	20	3	20	20	125	0,394	ISCR	₺969
D764	2525 3C-R DGN	25	25	3	22	25	150	0,711		₺1.041
D764-1	2525 3C-R DGN	25	25	3	25	25	150	0,711		₺1.085
D775	2020 4C-R DGN	20	20	4	20	20	125	0,391	DGN 4C	₺969
D777	2525 4C-R DGN	25	25	4	20	25	150	0,709	ISCR	₺1.041
Kod										
(D750-D752),(D758-D760)		TC131 M5x16			4 Allen					
D754,D775		TC132 M5x20			5 Allen					
D756,D764,D777		TC134 M6x20			5 Allen					

ISCR/L





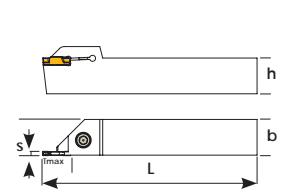
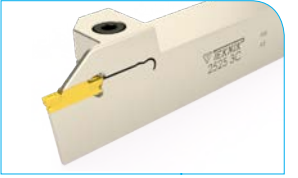

ISCR Ucuna Uygundur.

Sipariş Kodu	Ürün Kodu	Ölçüler (mm)							Uç	Fiyat
		h	b	S	Tmax	f	L			
D726	1212 2C-L DGN	12	12	2	16	12	125	0,158	DGN 2C	₺870
D727	1616 2C-L DGN	16	16	2	16	16	125	0,260	ISCR	₺920
D728	2020 2C-L DGN	20	20	2	18	20	125	0,398		₺969
D729	2525 2C-L DGN	25	25	2	19	25	150	0,712		₺1.041
D730	1212 3C-L DGN	12	12	3	16	12	125	0,160	DGN 3C	₺870
D731	1616 3C-L DGN	16	16	3	19	16	125	0,253	ISCR	₺920
D732	2020 3C-L DGN	20	20	3	20	20	125	0,394		₺969
D733	2525 3C-L DGN	25	25	3	22	25	150	0,711		₺1.041
Kod										
D726-D727,D730-D731		TC131 M5x16			4 Allen					
D728,D733		TC132 M5x20			5 Allen					
D728-D729,D732-D733		TC134 M5x20			5 Allen					

ZCC/R ZT-D



ZCC Ucuna Uygundur.

Sipariş Kodu	Ürün Kodu	Ölçüler (mm)							Uç	Fiyat
		h	b	S	Tmax	f	L			
D027	1616 3C-R ZT-D	16	16	3	18	16	125	0,301	ZT.D 3C	₺920
D028	2020 3C-R ZT-D	20	20	3	18	20	125	0,394	ZCC	₺969
D030	2525 3C-R ZT-D	25	25	3	22	25	150	0,755		₺1.041
D036	2020 4C-R ZT-D	20	20	4	18	20	125	0,400	ZT.D 4C	₺969
D038	2525 4C-R ZT-D	25	25	4	22	25	150	0,747	ZCC	₺1.041
D044	2020 5C-R ZT-D	20	20	5	18	20	125	0,391	ZT.D 5C	₺969
D046	2525 5C-R ZT-D	25	25	5	18	25	150	0,734	ZCC	₺1.041
D049	2525 6C-R ZT-D	25	25	6	18	25	150	0,745	ZT.D 6C	₺1.041
D051	3232 6C-R ZT-D	32	32	6	20	32	170	1,331	ZCC	₺1.143
Kod										
D027		TC131 M5x16			4 Allen					
D028,D036,D044		TC132 M5x20			5 Allen					
D030,D038,D046-D051		TC134 M6x20			5 Allen					

TKT/R TD

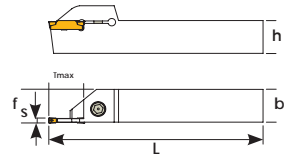

TGTC Ucuna Uygundur.

Sipariş Kodu	Ürün Kodu	Ölçüler (mm)							Uç	Fiyat	
		h	b	S	Tmax	f	L	(kg)			
D714	1212 2C-R TD	12	12	2	16	12	125	0,166	TD 2C	₺870	
D715	1616 2C-R TD	16	16	2	16	16	125	0,270	TGTC	₺920	
D716	2020 2C-R TD	20	20	2	16	20	125	0,401		₺969	
D717	2525 2C-R TD	25	25	2	18	25	150	0,728		₺1.041	
D718	1212 3C-R TD	12	12	2	16	12	125	0,160		₺870	
D719	1616 3C-R TD	16	16	3	18	16	125	0,256	TD 3C	₺920	
D720	2020 3C-R TD	20	20	3	18	20	125	0,398	TGTC	₺969	
D721	2525 3C-R TD	25	25	3	18	25	150	0,735		₺1.041	
D722	2020 4C-R TD	20	20	4	18	20	125	0,401	TD 4C	₺969	
D723	2525 4C-R TD	25	25	4	18	25	150	0,735	TGTC	₺1.041	
Kod											
D714-D715,D718-D719		TC131 M5x16									
D716,D720,D722		TC132 M5x20							4 Allen		
D717,D721,D723		TC134 M6x20							5 Allen		

K.HRN/R S224

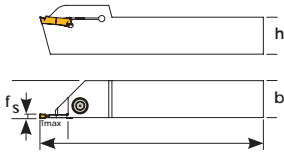
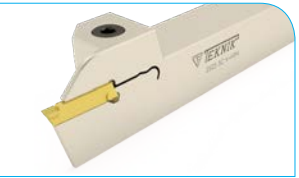

HRN Ucuna Uygundur.

Sipariş Kodu	Ürün Kodu	Ölçüler (mm)							Uç	Fiyat	
		h	b	S	Tmax	f	L	(kg)			
D700	1616 2C-R S224	16	16	2	18	16	125	0,258	2C S224	₺920	
D701	2020 2C-R S224	20	20	2	18	20	125	0,406	K.HRN	₺969	
D702	2525 2C-R S224	25	25	2	18	25	150	0,713		₺1.041	
D703	1616 3C-R S224	16	16	3	18	16	100	0,260	3C S224	₺920	
D704	2020 3C-R S224	20	20	3	18	20	125	0,407	K.HRN	₺969	
D705	2525 3C-R S224	25	25	3	18	25	150	0,720		₺1.041	
D706	2020 4C-R S224	20	20	4	18	20	125	0,401	4C S224	₺969	
D707	2525 4C-R S224	25	25	4	18	25	150	0,737	K.HRN	₺1.041	
D708	2020 5C-R S224	20	20	5	18	20	125	0,401	5C S224	₺969	
D710	2525 5C-R S224	25	25	5	18	25	150	0,730	K.HRN	₺1.041	
Kod											
D700,D703		TC131 M5x16									
D701,D702,D704,D706,D708		TC132 M5x20							4 Allen		
D705,D707,D710		TC134 M6x20							5 Allen		

B.HRN/R S229

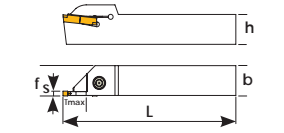
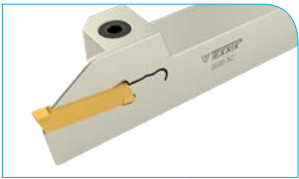

HRN Ucuna Uygundur.

Sipariş Kodu	Ürün Kodu	Ölçüler (mm)							Uç	Fiyat	
		h	b	S	Tmax	f	L	(kg)			
D688	2020 3C-R S229	20	20	3	22	20	125	0,391	3C S229	₺969	
D690	2525 3C-R S229	25	25	3	22	25	150	0,700	B.HRN	₺1.041	
D692	2020 4C-R S229	20	20	4	22	20	125	0,386	4C S229	₺969	
D694	2525 4C-R S229	25	25	4	22	25	150	0,705	B.HRN	₺1.041	
D696	2020 5C-R S229	20	20	5	22	20	125	0,389	5C S229	₺969	
D698	2525 5C-R S229	25	25	5	22	25	150	0,709	B.HRN	₺1.041	
Kod											
D688-D692,D696		TC132 M5x20							4 Allen		
D690,D694,D698		TC134 M6x20							5 Allen		

B.HRN/L S229

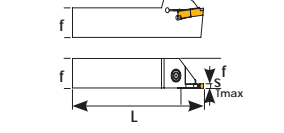

HRN Ucuna Uygundur.

Sipariş Kodu	Ürün Kodu	Ölçüler (mm)							Uç	Fiyat	
		h	b	S	Tmax	f	L	(kg)			
D711	2525 3C-L S229	25	25	3	22	25	150	0,700	3C S229 B.HRN	₺1.041	
D712	2525 4C-L S229	25	25	4	22	25	150	0,705	4C S229 B.HRN	₺1.041	
D713	2525 5C-L S229	25	25	5	22	25	150	0,709	5C S229 B.HRN	₺1.041	
Kod											
D711-D713		TC134 M6x20							5 Allen		

SDV 123/R

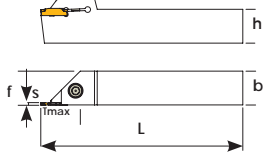

Sipariş Kodu	Ürün Kodu	Ölçüler (mm)							Uç	Fiyat
		h	b	S	Tmax	f	L	kg		
D900	2020 2C-123 SDV-R	20	20	2	18	20	125	0,400	123 2C	₺969
D902	2525 2C-123 SDV-R	25	25	2	18	25	150	0,732	SDV	₺1.041
D904	2020 3C-123 SDV-R	20	20	3	19	20	125	0,397	123 3C	₺969
D906	2525 3C-123 SDV-R	25	25	3	20	25	150	0,713	SDV	₺1.041
D908	2020 4C-123 SDV-R	20	20	4	18	20	125	0,415	123 4C	₺969
D910	2525 4C-123 SDV-R	25	25	4	18	25	150	0,724	SDV	₺1.041
D912	2525 5C-123 SDV-R	25	25	5	18	25	150	0,725	123 SDV 5C	₺1.041
Kod										
D900,D904,D908		TC132 M5x20		4 Allen						
D902,D906,D910-D912		TC134 M6x20		5 Allen						

SNDVK Ucuna Uygundur.

SDV 123/L

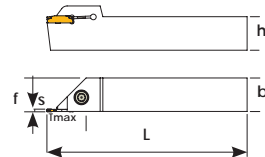

Sipariş Kodu	Ürün Kodu	Ölçüler (mm)							Uç	Fiyat
		h	b	S	Tmax	f	L	kg		
D873	2020 2C-123 SDV-L	20	20	2	18	20	125	0,400	123 2C	₺969
D874	2525 2C-123 SDV-L	25	25	2	18	25	150	0,732	SDV	₺1.041
D875	2020 3C-123 SDV-L	20	20	3	19	20	125	0,397	123 3C	₺969
D876	2525 3C-123 SDV-L	25	25	3	20	25	150	0,713	SDV	₺1.041
D877	2020 4C-123 SDV-L	20	20	4	18	20	125	0,415	123 4C	₺969
D878	2525 4C-123 SDV-L	25	25	4	18	25	150	0,724	SDV	₺1.041
D879	2525 5C-123 SDV-L	25	25	5	18	25	150	0,725	123 5C SDV	₺1.041
Kod										
D873,D875,D877		TC132 M5x20		4 Allen						
D874,D876,D878-D912		TC134 M6x20		5 Allen						

SNDVK Ucuna Uygundur.

DGM 2-3

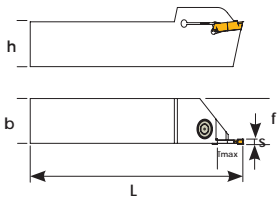

Sipariş Kodu	Ürün Kodu	Ölçüler (mm)							Uç	Fiyat
		h	b	S	Tmax	f	L	kg		
D842	1212 2C-DGM 2	12	12	2	16	12	125	0,166		₺870
D843	1616 2C-DGM 2	16	16	2	17	16	125	0,267	DGM 2C	₺920
D844	2020 2C-DGM 2	20	20	2	17	20	125	0,403	TNGLY	₺969
D845	2525 2C-DGM 2	25	25	2	17	25	150	0,739		₺1.041
D847	1212 3C-DGM 3	12	12	3	16	12	125	0,168		₺870
D848	1616 3C-DGM 3	16	16	3	17	16	125	0,263	DGM 3C	₺920
D849	2020 3C-DGM 3	20	20	3	20	20	125	0,395	TNGLY	₺969
D850	2525 3C-DGM 3	25	25	3	20	25	150	0,740		₺1.041
Kod										
D842,D843		TC131 M5x16		4 Allen						
D844,D847-D849		TC132 M5x20		5 Allen						
D845-D850		TC134 M6x20								

TNGLY Ucuna Uygundur.

GX16-GX24

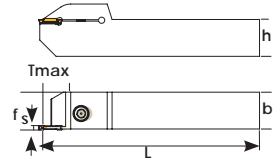

Sipariş Kodu	Ürün Kodu	Ölçüler (mm)							Uç	Fiyat	
		h	b	S	Tmax	f	L	KG			
D858	2020 2C GX16	20	20	2	18	20	125	0,267	GX 16 2C WLTR	₺969	
D859	2525 2C GX16	25	25	2	18	25	150	0,403	GX 16 2C WLTR	₺1.041	
D860	2020 3C GX16	20	20	3	20	20	125	0,395	GX 16 3C WLTR	₺969	
D861	2525 3C GX16	25	25	3	22	25	150	0,740	GX 16 3C WLTR	₺1.041	
D864	2020 2C GX24	20	20	2	18	20	125	0,403	GX 24 2C WLTR	₺969	
D865	2525 2C GX24	25	25	2	18	25	150	0,739	GX 24 2C WLTR	₺1.041	
D866	2020 3C GX24	20	20	3	20	20	125	0,395	GX 24 3C WLTR	₺969	
D867	2525 3C GX24	25	25	3	22	25	150	0,740	GX 24 3C WLTR	₺1.041	
Kod											
D858,D860,D864, D866		TC132 M5x20		4 Allen							
D859,D861,D865-D867		TC134 M6x20		5 Allen							

WLTR Ucuna Uygundur.

Diş Çap Kanal Açma Kayar Otomat Takımı

MGMN

NEW PRODUCT

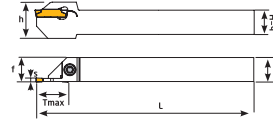

Sipariş Kodu	Ürün Kodu	Ölçüler (mm)							Uç	Fiyat	
		h	b	S	Tmax	f	L	KG			
D010	1212 2C MGMN 200	12	12	2	12	12,2	125	0,166	MGMN 200 KRLY	₺870	
D011	1616 2C MGMN 200	16	16	2	16	16,2	125	0,267	MGMN 200 KRLY	₺920	
D013	1212 3C MGMN 300	12	12	3	12	12,3	125	0,166	MGMN 300 KRLY	₺870	
D014	1616 3C MGMN 300	16	16	3	16	16,3	125	0,267	MGMN 300 KRLY	₺920	
Kod											
D010-D014		TC074 M4x10		T15							

KRLY Ucuna Uygundur.

Diş Çap Kanal Açma Kayar Otomat Takımı

KGMN

NEW PRODUCT

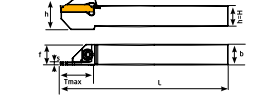

Sipariş Kodu	Ürün Kodu	Ölçüler (mm)							Uç	Fiyat	
		h	b	S	Tmax	f	L	KG			
D016	1212 2C KGMN 200	12	12	2	12	12,2	125	0,166	KGMN 200 KRLY	₺870	
D017	1616 2C KGMN 200	16	16	2	16	16,2	125	0,267	KGMN 200 KRLY	₺920	
Kod											
D016-D017		TC074 M4x10		T15							

KRLY Ucuna Uygundur.

Diş Çap Kanal Açma Kayar Otomat Takımı

DGN

NEW PRODUCT

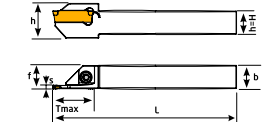

Sipariş Kodu	Ürün Kodu	Ölçüler (mm)							Uç	Fiyat	
		h	b	S	Tmax	f	L	KG			
D019	1212 2C DGN	12	12	2	12	12,2	125	0,166	DGN 2C ISCR	₺870	
D020	1616 2C DGN	16	16	2	16	16,2	125	0,267	DGN 2C ISCR	₺920	
D021	1212 3C-DGN	12	12	3	12	12,3	125	0,166	DGN 3C ISCR	₺870	
D022	1616 3C-DGN	16	16	3	16	16,3	125	0,267	DGN 3C ISCR	₺920	
Kod											
D019-D022		TC074 M4x10		T15							

ISCR Ucuna Uygundur.

MGMN

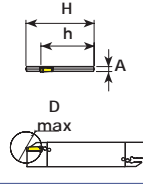

Sipariş Kodu	Ürün Kodu	Ölçüler (mm)					Uç	Fiyat
		H	h	A	L	D max		
KL29	32-2	32	25	2	150	36	MGMN 200 KRLY	₺969
KL30	32-3	32	25	2,45	150	36	MGMN 300 KRLY	₺969
KL32	32-4	32	25	3,45	150	36	MGMN 400 KRLY	₺969

KGMN

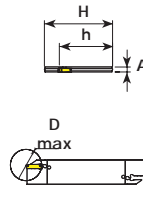
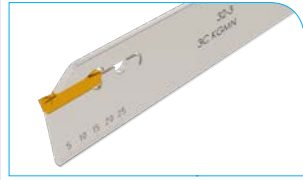

Sipariş Kodu	Ürün Kodu	Ölçüler (mm)					Uç	Fiyat
		H	h	A	L	D max		
KL37	26-2	26	21,4	1,65	110	36	KGMN 200 KRLY	₺920
KL38	26-3	26	21,4	2,45	110	36	KGMN 300 KRLY	₺920
KL39	26-4	26	21,4	3,45	110	36	KGMN 400 KRLY	₺920
KL34	32-2	32	25	1,65	150	36	KGMN 200 KRLY	₺969
KL35	32-3	32	25	2,45	150	36	KGMN 300 KRLY	₺969
KL36	32-4	32	25	3,45	150	36	KGMN 400 KRLY	₺969

SP

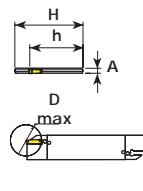
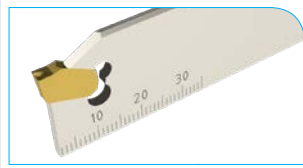

Sipariş Kodu	Ürün Kodu	Ölçüler (mm)					Uç	Fiyat
		H	h	A	L	D max		
KL40	26-3	26	21,4	2,45	110		SP 300 KRLY	₺920
KL42	26-4	26	21,4	3,45	110		SP 400 KRLY	₺920
KL44	32-3	32	25	2,45	150		SP 300 KRLY	₺969
KL45	32-4	32	25	3,45	150		SP 400 KRLY	₺969

N151-3

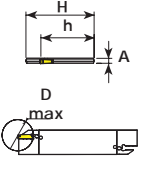
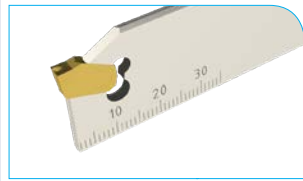

Sipariş Kodu	Ürün Kodu	Ölçüler (mm)					Uç	Fiyat
		H	h	A	L	D max		
KL52	26-3	26	21,4	2,45	110		N151-3 SDV	₺920
KL54	26-4	26	21,4	3,45	110		N151-4 SDV	₺920
KL56	32-3	32	25	2,45	150		N151-3 SDV	₺969
KL58	32-4	32	25	3,45	150		N151-4 SDV	₺969

SDV 123

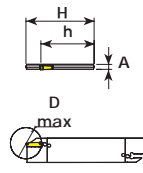
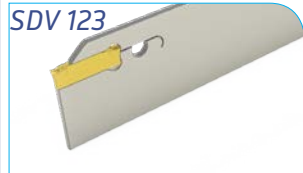

Sipariş Kodu	Ürün Kodu	Ölçüler (mm)					Uç	Fiyat
		H	h	A	L	D max		
KL60	32-3	32	25	2,45	150		123 3C SDV	₺971
KL61	32-4	32	25	3,45	150		123 4C SDV	₺971

DGN

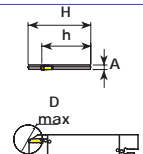

Sipariş Kodu	Ürün Kodu	Ölçüler (mm)					Uç	Fiyat
		H	h	A	L	D max		
KL20	32-3	32	25	2,45	150	36	DGN3	₺969
KL22	32-4	32	25	3,45	150	36	DGN4	₺969

GTN

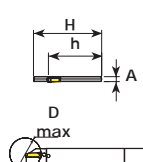
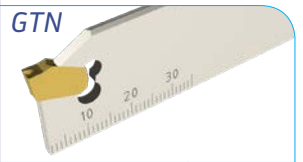

KL23	26-3	26	21,4	2,45	110		GTN3	₺920
KL24	26-4	26	21,4	3,45	110		GTN4	₺920
KL25	32-3	32	25	2,45	150		GTN3	₺969
KL26	32-4	32	25	3,45	150		GTN4	₺969

Keski Kütüğü

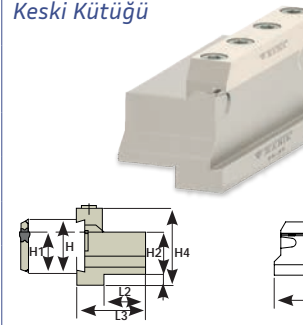

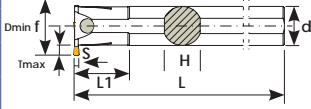

Sipariş Kodu	Ürün Kodu	Ölçüler (mm)						Fiyat
		H	L1	L2	H1	H2	L3	
KLT04	20-26	26	87	19	21,4	20	33	₺1.540
KLT05	25-26	26	110	20	24,4	25	34	₺1.540
KLT06	20-32	32	110	19	25	20	35	₺1.586
KLT08	25-32	32	110	20	25	25	36	₺1.663
KLT10	32-32	32	110	28	25	32	44	₺1.786

KRLY/R





Sipariş Kodu	Ürün Kodu	Ölçüler (mm)										Uç	Fiyat
		Dmin	Tmax	L	L1	d	h	f	s				
K600	S16Q 2C-R MGM	21	5	180	35	16	15	12,5	2	0,288	MGM 200	₺870	
K602	S20Q 2C-R MGM	26	5,7	180	35	20	18	15,5	2	0,440	KRLY	₺944	
K603	S25R 2C-R MGM	31	5,7	200	35	25	23	18	2	0,787		₺969	
K604	S20Q 3C-R MGM	26	6	180	35	20	18	15,5	3	0,450		₺944	
K606	S25R 3C-R MGM	32	6,7	200	40	25	23	19	3	0,784	MGM 300	₺969	
K608	S32S 3C-R MGM	38	6,1	250	60	32	30	21,5	3	1,555	KRLY	₺1.219	
K609	S40T 3C-R MGM	48	7,2	300	60	40	38	27	3	2,940		₺1.788	
K610	S20Q 4C-R MGM	26	6	180	35	20	18	15,5	4	0,443		₺944	
K612	S25R 4C-R MGM	31	6	200	40	25	23	18,2	4	0,783	MGM 400	₺969	
K614	S32S 4C-R MGM	38	6	250	65	32	30	21,5	4	1,552	KRLY	₺1.219	
K616	S40T 4C-R MGM	47	7,2	300	60	40	38	27	4	2,942		₺1.788	
K618	S25R 5C-R MGM	32	7	200	40	25	23	19,2	5	0,777	MGM 500	₺969	
K620	S32S 5C-R MGM	39	7	250	60	32	30	22,5	5	1,561	KRLY	₺1.219	
K622	S40T 5C-R MGM	47	7,4	300	60	40	38	27	5	2,936		₺1.788	

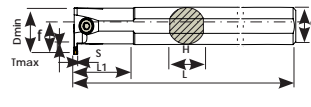

Kod			
K600-K602,K604,K610	TC130 M5x12		
K603,K606,K612,K618	TC131 M5x16	4 Allen	
K608-K609,K614-K616,K620-K622	TC134 M6x20	5 Allen	

KRLY Ucuna Uygunur.

KGMN





Sipariş Kodu	Ürün Kodu	Ölçüler (mm)										Uç	Fiyat
		Dmin	Tmax	L	L1	d	h	f	s				
K660	S16K 2C KGMN	23	6,5	125	35	16	15	14	2	0,220	KGMN 200	₺870	
K661	S20M 2C KGMN	25	6,5	150	45	20	18	15,5	2	0,374	KRLY	₺944	
K662	S25R 2C KGMN	32	7	200	45	25	23	19	2	0,802		₺969	
K663	S20M 3C KGMN	25	6,5	150	45	20	18	15,5	3	0,370	KGMN 300	₺944	
K664	S25R 3C KGMN	32	7	200	45	25	23	19	3	0,800	KRLY	₺969	
K665	S32S 3C KGMN	40	7,5	250	55	32	30	22,5	3	1,627		₺1.219	
K666	S20M 4C KGMN	25	6,5	150	45	20	18	15,5	4	0,374	KGMN 400	₺944	
K667	S25R 4C KGMN	32	7	200	45	25	23	19	4	0,796	KRLY	₺969	
K668	S32S 4C KGMN	40	7,5	250	55	32	30	22,5	4	1,623		₺1.219	

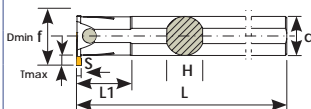

Kod			
K660-K661,K663,K666	TC130 M5x12	4 Allen	
K662,K664,K667	TC131 M5x16	5 Allen	
K665,K668	TC134 M6x20		

KRLY Ucuna Uygunur.

HRN/R S229



Sipariş Kodu	Ürün Kodu	Ölçüler (mm)										Uç	Fiyat
		Dmin	Tmax	L	L1	d	h	f	s				
K624	S25R 3C-R S229	34	9,8	200	50	25	23	21,5	3	0,766	3C S229	₺969	
K626	S32S 3C-R S229	41	9	250	50	32	30	24,5	3	1,560	B.HRN	₺1.219	
K628	S40T 3C-R S229	49	9	300	50	40	38	21,5	3	2,594		₺1.788	
K630	S25R 4C-R S229	34	9,8	200	50	25	23	24,5	4	0,768	4C S229	₺969	
K632	S32S 4C-R S229	42	9	250	50	32	30	23,5	4	1,656	B.HRN	₺1.219	
K634	S40T 4C-R S229	49	9	300	50	40	38	28,5	4	3,113		₺1.788	
K636	S25R 5C-R S229	33	9,5	200	50	25	23	21	5	0,770	5C S229	₺969	
K638	S32S 5C-R S229	41	9	250	50	32	30	24,5	5	1,659	B.HRN	₺1.219	
K640	S40T 5C-R S229	49	9	300	50	40	38	28,5	5	3,109		₺1.788	

Kod			
K624,K630,K636	TC131 M5x20	4 Allen	
K626-K628,K632-K634,K638-K640	TC134 M6x20	5 Allen	

HRN Ucuna Uygunur.

SDV/R 123

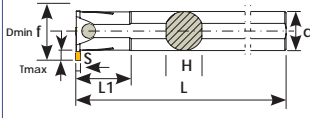

SNDVK Ucuna Uygundur.

Sipariş Kodu	Ürün Kodu	Ölçüler (mm)										Uç	Fiyat
		Dmin	Tmax	L	L1	d	h	f	s	kg			
K720	S25R 3C-R-123 SDV	32	7	200	40	25	23	19,5	3	0,784	123 3C	₺969	
K722	S32S 3C-R-123 SDV	39	7	250	60	32	30	23	3	1,567	SNDVK	₺1.219	
K726	S25R 4C-R-123 SDV	32	7	200	40	25	23	19,5	4	0,772	123 4C	₺969	
K728	S32S 4C-R-123 SDV	39	7	250	60	32	30	23	4	2,854	SNDVK	₺1.219	
K730	S25S 5C-R-123 SDV	32	7	200	40	25	23	19,5	5	0,785	123 5C	₺969	
K732	S32S 5C-R-123 SDV	39	7	250	60	32	30	19,5	5	1,564	SNDVK	₺1.219	
Kod													
K720,K726,K730		TC131 M5x16			4 Allen								
K722-K728,K732		TC134 M6x20			5 Allen								

HRN/R S224

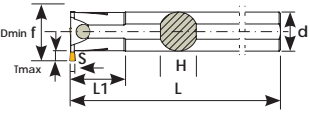

HRN Ucuna Uygundur.

Sipariş Kodu	Ürün Kodu	Ölçüler (mm)										Uç	Fiyat
		Dmin	Tmax	L	L1	d	h	f	s	kg			
K642	S20Q 2C-R S224	26	6,5	180	40	20	18	16	2	0,444	2C S224	₺944	
K644	S25R 2C-R S224	34	9	200	50	25	23	21	2	0,763	K.HRN	₺969	
K646	S20Q 3C-R S224	26	6,5	180	40	20	18	16	3	0,459	3C S224	₺944	
K648	S25R 3C-R S224	33	9	200	50	25	23	20,5	3	0,782	K.HRN	₺969	
K650	S32S 3C-R S224	40	9	250	50	32	30	24	3	1,633		₺1.219	
K652	S20Q 4C-R S224	26	6,5	180	40	20	18	16	4	0,440	4C S224	₺944	
K654	S25R 4C-R S224	33	9	200	50	25	23	20,5	4	0,764	K.HRN	₺969	
K656	S32S 4C-R S224	42	9	250	50	32	30	23,5	4	1,672		₺1.219	
Kod													
K642,K646,K652		TC130 M5x12			4 Allen								
K644,K648,K654		TC131 M5x16			5 Allen								
K650,K656		TC134 M6x20											

ZCC/R ZT.D

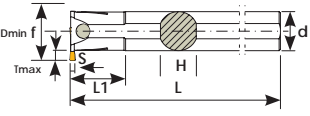

ZCC Ucuna Uygundur.

Sipariş Kodu	Ürün Kodu	Ölçüler (mm)										Uç	Fiyat
		Dmin	Tmax	L	L1	d	h	f	s	kg			
K679	S16Q 2C-R ZT.D	20	4,9	180	35	16	15	12,5	2	0,446	ZT.D 2C ZCC	₺870	
K680	S20Q 3C-R ZT.D	26	5,5	180	35	20	18	15	3	0,661	ZT.D 3C	₺944	
K681	S25R 3C-R ZT.D	33	7,5	200	35	25	23	20	3	1,576	ZCC	₺969	
K682	S32S 3C-R ZT.D	39	7	250	50	32	30	23	3	1,641		₺1.219	
K684	S25R 4C-R ZT.D	33	7,5	200	35	25	23	20	4	1,578	ZT.D 4C	₺969	
K685	S32S 4C-R ZT.D	39	7	250	50	32	30	23	4	1,645	ZCC	₺1.219	
Kod													
K679,K680		TC130 M5x12			4 Allen								
K681,K684		TC131 M5x16			5 Allen								
K682-K685		TC134 M6x20											

DGN/R

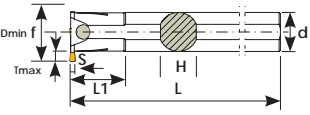



ISCR Uclarına uygundur.

Sipariş Kodu	Ürün Kodu	Ölçüler (mm)										Uç	Fiyat
		Dmin	Tmax	L	L1	d	h	f	s	kg			
K672	S20Q 3C-R DGN	25	5,5	180	35	20	18	15,0	3	0,308	DGN 3C	₺944	
K673	S25R 3C-R DGN	31	6	200	40	25	23	18,5	3	0,463	ISCR	₺969	
K674	S32S 3C-R DGN	37	6	250	55	32	30	30	3	0,809		₺1.219	
K676	S20Q 4C-R DGN	25	5,5	180	35	20	18	18	4	0,463	DGN 4C	₺944	
K677	S25R 4C-R DGN	31	6	200	40	25	23	23	4	0,810	ISCR	₺969	
K678	S32S 4C-R DGN	37	6	250	55	32	30	30	4	1,655		₺1.219	
Kod													
K672,K676		TC130 M5x12			4 Allen								
K673,K677		TC131 M5x16			5 Allen								
K674-K678		TC134 M6x20											

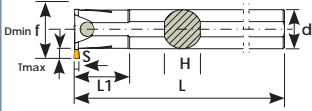
GRP/R





Sipariş Kodu	Ürün Kodu	Ölçüler (mm)										Uç	Fiyat
		Dmin	Tmax	L	L1	d	h	f	s				
K700	S16Q 3C-R GRP	21	4,9	180	45	16	18	12,5	3	0,308	GRP 3C	₺868	
K702	S20Q 3C-R GRP	26	6	180	35	20	18	15,7	3	0,463	ISCR	₺943	
K704	S25R 3C-R GRP	32	6,5	200	35	25	23	18,7	3	0,809		₺968	
K706	S20Q 4C-R GRP	26	5,5	180	35	20	18	15,2	4	0,463	GRP 4C	₺943	
K708	S25R 4C-R GRP	32	6,5	200	35	25	23	18,7	4	0,810	ISCR	₺968	
K710	S32S 4C-R GRP	38	6,5	250	60	32	30	22	4	1,655		₺1.219	

Kod		
K700,K702,K706,K708	TC130 M5x12	4 Allen
K704,K708	TC131 M5x16	5 Allen
K710	TC134 M6x20	

ISCR Ucuna Uygundur.

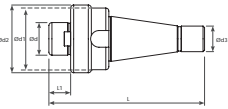
ISO 40



Sipariş Kodu	Ürün Kodu	Şaft	Ölçüler (mm)							Fiyat
			d	d2	d1	d3	L	L1		
M206	ISO 40-16	ISO 40	16	54	38	25	154	17	1,232	₺1.788
M208	ISO 40-22	ISO 40	22	54	50	25	154	19	1,371	₺1.788
M210	ISO 40-27	ISO 40	27	55	59	25	154	21	1,413	₺1.788
M212	ISO 40-32	ISO 40	32	61	67	25	154	24	1,750	₺1.788
M214	ISO 40-40	ISO 40	40	61	73	25	154	27	1,956	₺1.788

ISO 50

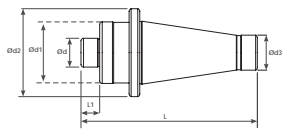

Sipariş Kodu	Ürün Kodu	Şaft	Ölçüler (mm)							Fiyat
			d	d2	d1	d3	L	L1		
M216	ISO 50-22	ISO 50	22	98	52	39	196	19	3,640	₺2.763
M218	ISO 50-27	ISO 50	27	98	61	39	196	21	3,976	₺2.763
M220	ISO 50-32	ISO 50	32	98	68	39	196	24	3,817	₺2.763
M222	ISO 50-40	ISO 50	40	98	98	39	196	27	4,512	₺2.763
M224	ISO 50-60	ISO 50	60	108	108	39	196	26	5,562	₺2.763

Mini Kanal Kater

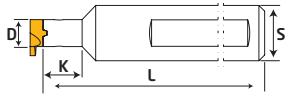

Sipariş Kodu	Ürün Kodu	Ölçüler (mm)					Uç	Fiyat
		S	D	K	L	kg		
K801	S12 D5,9 K24 L080	12	5,9	24	80	0,143	NFTG 08 KRLY	₺944
K802	S12 D08 K33 L095	12	8	33	98	0,126	NFTG 11 KRLY	₺944
K803	S12 D09 K45 L110	12	9	45	110	0,120	NFTG 14 KRLY	₺944
K804	S12 D11 K48 L130	12	11	48	130	0,348	NFTG 16 KRLY	₺944
Kod								
K801		TC063 M2,5x7						
K802		TC069 M3,5x8,5						
K803		TC074 M4x10						
K804		TC085 M5x12						

KRLY Ucuna Uygunur.

Mini Kanal Kater

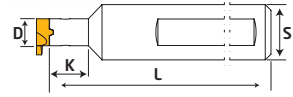

Sipariş Kodu	Ürün Kodu	Ölçüler (mm)					Uç	Fiyat
		S	D	K	L	kg		
K810	S16 D08 K11 L093	16	8	11	93	0,098	D08	₺944
K812	S16 D09 K20 L093	16	9	20	93	0,102	D09	₺944
K814	S16 D06 K11 L081	16	6	11	81	0,082	D06	₺944
K816	S20 D14 K49 L160	20	14	49	160	0,367	D14	₺993
Kod								
K810		TC069 M3,5x8,5						
K812		TC074 M4x10						
K814		TC063 M2,5x7						
K816		TC085 M5x12						

MINI TOOL

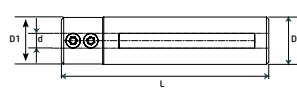
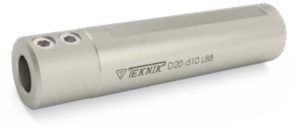

Sipariş Kodu	Ürün Kodu	Ölçüler (mm)					Fiyat	
		D	d	L	D1	kg		
DC304	D16 d03 L88	16	3	88	19,65	0,134	M6x50 M6x8	₺854
DC306	D20 d03 L88	20	3	88	19,65	0,228	M6x50 M6x8	₺854
DC310	D12 d04 L88	12	4	88	11,65	0,075	M6x50 M6x5	₺854
DC312	D16 d04 L75	16	4	75	19,65	0,139	M6x35 M6x8	₺854
DC314	D16 d04 L88	16	4	88	19,65	0,159	M6x50 M6x8	₺854
DC316	D20 d04 L88	20	4	88	19,65	0,222	M6x50 M6x8	₺854
DC318	D22 d04 L88	22	4	88	21,65	0,274	M6x50 M6x8	₺854
DC320	D12 d05 L88	12	5	88	11,65	0,067	M6x50 M6x5	₺854
DC322	D16 d05 L75	16	5	75	19,65	0,135	M6x35 M6x8	₺854
DC324	D16 d05 L88	16	5	88	19,65	0,153	M6x50 M6x8	₺854
DC326	D20 d05 L88	20	5	88	19,65	0,221	M6x50 M6x8	₺854
DC328	D22 d05 L88	22	5	88	21,65	0,274	M6x50 M6x8	₺854
DC334	D20 d06 L88	20	6	88	19,65	0,227	M6x50 M6x8	₺854
DC340	D20 d07 L88	20	7	88	19,65	0,219	M6x50 M6x8	₺854
DC344	D16 d08 L88	16	8	88	19,65	0,142	M6x50 M6x8	₺854
DC346	D20 d08 L88	20	8	88	19,65	0,214	M6x50 M6x5	₺854
DC350	D16 d10 L88	16	10	88	19,65	0,130	M6x50 M6x5	₺854
DC352	D20 d10 L88	20	10	88	19,65	0,201	M6x50 M6x5	₺854

<i>Torna Kateri</i>	Sipariř Kodu	Ürün Kodu		Uç	Fiyat
	RP100	TORNA KATERİ	6x18		₺975
	RP102	TORNA KATERİ	8x10	HSS KALEM	₺975
	RP104	TORNA KATERİ	10x12		₺975
	RP106	TORNA KATERİ	12x14		₺1.049



<i>Kesme Kateri</i>	Sipariř Kodu	Ürün Kodu		Uç	Fiyat
	RP110	KESME KATERİ	1/2	12 HSS KALEM	₺915
	RP112	KESME KATERİ	5/8	16 HSS KALEM	₺915
	RP114	KESME KATERİ	3/4	20 HSS KALEM	₺915
	RP116	KESME KATERİ	7/8	22 HSS KALEM	₺975
	RP118	KESME KATERİ	1"	25 HSS KALEM	₺975









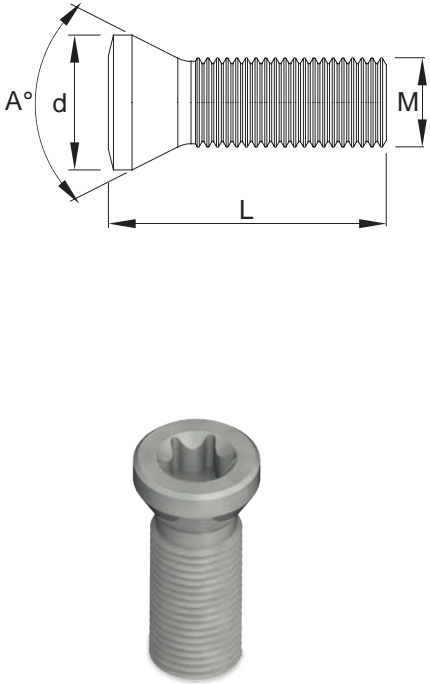
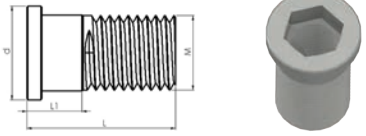

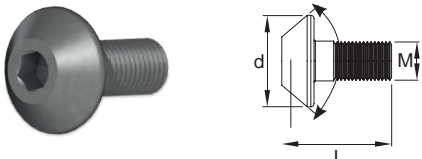

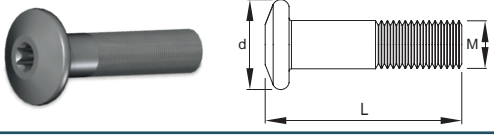
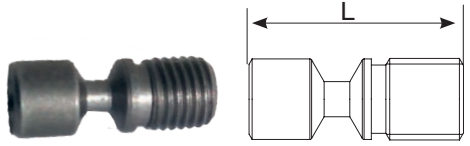



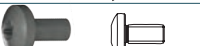

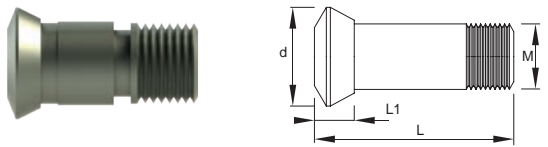



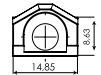



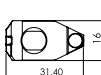



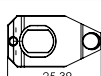

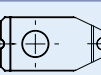

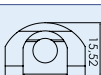
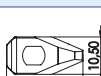

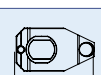

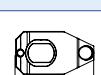

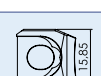
<i>Tekli - Çiftli Tirtil Kateri</i>	Sipariř Kodu	Ürün Kodu		Uç	Fiyat
	RP122	25x25 TEKLİ TIRTIL KATERİ		20x10x6	₺720
	RP120	25x25 ÇİFTLİ TIRTIL KATERİ		HSS 20x10x6	₺926









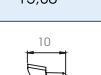

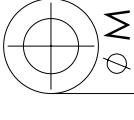

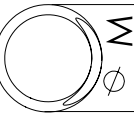

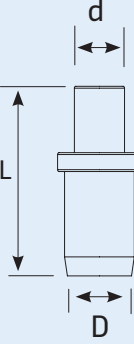

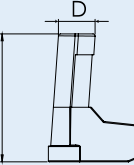





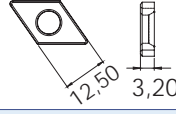

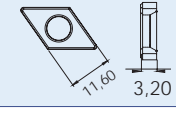

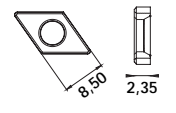

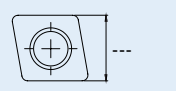

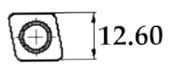

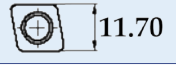

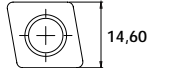

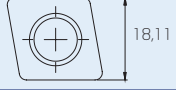

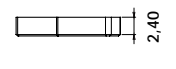
	Sipariř Kodu	Ürün Kodu		Fiyat
	700	SN 50 TORNA KALEMLİĐİ		₺5.449
	710	SN 50 CİVATASI M14		₺58
	709	SN 50 CİVATASI M16		₺58
	712	SN 50 KALEMLİK ANAHTARI		₺1.098

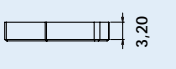

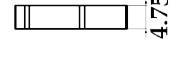

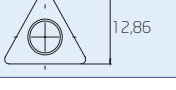

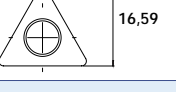

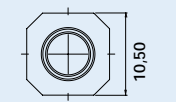

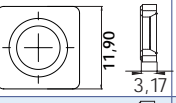

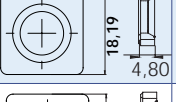

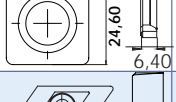



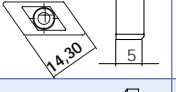

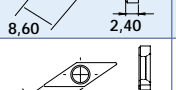

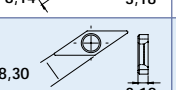

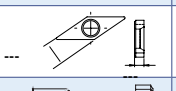

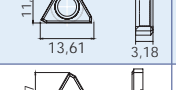

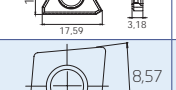



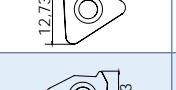

Parça	Kod	M	L	d	A	Anahtar	Fiyat
	TC057	M1,6	3,4	2,6	60°	T6	₺59
	TC057-1	M1,8	4,1	2,5	60°	T6	₺59
	TC058	M2	4,2	2,8	60°	T6	₺59
	TC058-1	M2	5	2,8	60°	T6	₺59
	TC058-2	M2,2	6	3	60°	T7	₺59
	TC059	M2,2	5	3	60°	T7	₺59
	TC059-1	M2,5	4,7	3,5	60°	T8	₺15
	TC060	M2,5	5,5	3,5	60°	T8	₺15
	TC061	M2,5	6,5	3,5	50°	T8	₺15
	TC063	M2,5	7	3,5	60°	T8	₺15
	TC092	M2,5	5,5	3,8	60°	T8	₺15
	TC093	M2,5	7	3,8	60°	T8	₺15
	TC064	M3	6,2	3,8	60°	T8	₺15
	TC065	M3	7	4,2	60°	T8	₺15
	TC065-1	M3	7	4	60°	T8	₺15
	TC066	M3,5	10	5,3	55°	T15	₺15
	TC067	M3,5	8,5	5,3	60°	T15	₺15
	TC068	M3,5	11	5,3	60°	T15	₺15
	TC069	M3,5	8,5	4,8	60°	T10	₺15
	TC071	M3,5	7	5,3	60°	T15	₺15
	TC072	M4	10	5,5	60°	T15	₺15
	TC073	M4	8,5	5,5	60°	T15	₺15
	TC074	M4	10	5,5	60°	T15	₺15
	TC075	M4	11	7	60°	T15	₺15
	TC076	M4	12,5	5,5	60°	T15	₺15
	TC077	M4	15	6,8	60°	T15	₺15
	TC078	M4	11	6,7	60°	T15	₺15
	TC079	M4	11	5,2	45°	T15	₺15
	TC080	M4,5	11	6,2	60°	T15	₺15
	TC083	M5	12	7	60°	T20	₺15
	TC085	M5	12	6,6	75°	T20	₺15
	TC086	M5	18	7,5	60°	T20	₺15
		TC048	M5	9	6,3		4 Allen
TC049		M5	7,7			3,5 Allen	₺53
TC049-1		M6	10			4 Allen	₺53

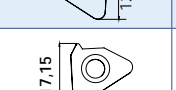
Parça	Kod	M	L	d	Anahtar	Fiyat
	TC050	M6	14	11,2	3 Allen	₺15
	TC052	M6	17	14	4 Allen	₺15
	TC054	M8	24	17,1	5 Allen	₺15
	TC056	M8 (sol-left)	24	17,1	5 Allen	₺15
	TC300	M8	21		4 Allen	₺61
	TC044	M6	27	11	3 Allen	₺15
	TC046	M5	26	10	3 Allen	₺15
	TC047	M8	29	13,6	5 Allen	₺53
	TH512	M5	12		2 Allen	₺71
	TH613	M6	13,4		2,5 Allen	₺71
	TH617	M6	17		2 Allen	₺71
	TH818	M8	18		3 Allen	₺71
	TH821	M8	21		3 Allen	₺71
	TH822	M8	22		2,5 Allen	₺71
	TH825	M8	25		3 Allen	₺71
	TC036	M3	10	5,6	T10	₺9
	TC038	M4	10	7,30	T15	₺9
	TC039	M6	12	10,6	4 Allen	₺9
	TC040	M3,5	10	8	T15	₺9
	TC062	M3	6,7	5,5	T15	₺18
	TC053	M4	9	6,5	T20	₺18
	TC053-1	M4	9	6,5	T15	₺18
	TC095	M5	12	9,5	3 Allen	₺9
	TC170	M3	7	4,2	T8	₺9
	TC172	M4	9	5,8	T15	₺9
	TC174	M5	10	7	T20	₺20
	TC176	M5	12	7,3	T20	₺20
	TC178	M5	16	7,8	3 Allen	₺20
	TC181	M6	22	9,5	3 Allen	₺78
	TC184	M8	25	13	4 Allen	₺78

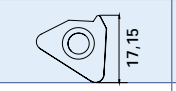
Kod	Tip	Parça	Ölçüler (mm)	Fiyat
			M	
BK017	DNMG 11			₺96
BK017-1	TNMG 16			₺96
BK018	CNMG 16			₺120
BK019	WNMG 06			₺96
BK020	DNMG 15 CNMG 12 SNMG 12			₺96
BK021	VNMG 16			₺96
BK022	TNMG 16			₺96
BK023	TNMG 22			₺96
BK024	DNMG 11 (Small)			₺96
BK025	CNMG 19			₺120
BK027	SNMG 25			₺135
BK026	WNMG 08			₺96
BK028	KNUX Sağ/ Right			₺120
BK030	KNUX/Left			₺120
BK035	RDMT 16			₺93
BK036	TPKN16			₺93
BK300	OFCR 07			₺98

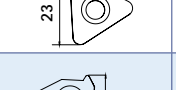









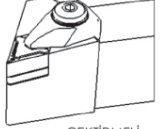
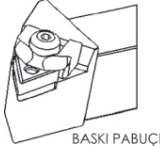
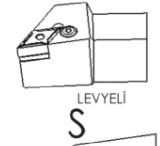
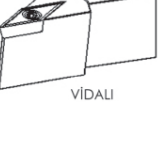

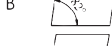







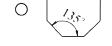
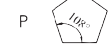



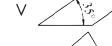

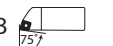
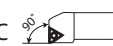



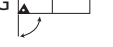

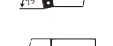



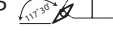







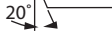

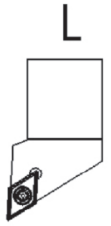
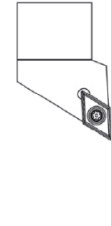





Kod	Tip	Parça	Ölçüler (mm)	Fiyat	
			M		
BSP010	Baskı Pulu			₺9	
BSP030	Baskı Pulu (Normal)			₺9	
BSP031	Baskı Pulu			₺9	
BSP032	Baskı Pulu			₺9	
BY040	M6			₺9	
BY041	M5			₺9	
BY042	M6			₺9	
BY043	M5			₺9	
BY044				₺9	
BSP020	TNMG 16 WNMG 06	D:5 d:3,5 L:14,5			₺39
BSP021	TNMG 22 DNMG 11 WNMG 08	D:6 d:5 L:15			₺39
TL3	L12,2-D3,5			₺145	
TL3B	L10-D3			₺145	
TL4	L13-D4,5			₺145	
TL4A	L10,5-D4,7			₺145	
TL4B	L15,6-D5			₺145	
TS-3	D6,65-L5,5				
TS-4	D7,71-L7	₺61			

Kod	Tip	Parça	Ölçüler (mm)	Fiyat
			M	
TA014	DNMG 15 Shim			₺110
TA014-1	DNMG 15 Shim			₺110
TA013	DNMG 11 Shim			₺98
TA023	CNMG 09 Shim			₺98
TA016	CNMG 12 Shim			₺110
TA016-1	CNMG 12 Shim			₺110
TA022	CNMG 16 Shim			₺131
TA017	CNMG 19 Shim			₺233
TA021	WNMG 06 Shim			₺98
TA020-1	WNMG 08 Shim			₺106
TA020	WNMG 08 Shim			₺146
TA019	TNMG 16 Shim			₺93
TA045	TNMG 22 Shim			₺155
TA052	SEET 12 Shim			₺98

Kod	Tip	Parça	Ölçüler (mm)	Fiyat
			M	
TA050	SNMG 12 Shim			₺110
TA051	SNMG 19 Shim			₺200
TA053	SNMG 25 Shim			₺233
TA046	KNUX RIGHT Shim			₺155
TA048	KNUX LEFT Shim			₺155
TA030	DCMT 11 Shim			₺98
TA034	VBMT 16 Shim			₺110
TA032	VCMT 16 Shim			₺110
TA033	VNMG 16 Shim			₺110
TA010	TPKN 16 Shim			₺98
TA012	TPKN 22 Shim			₺110
TA015	CCMT 09 Shim			₺98
TA015-1	CCMT 12 Shim			₺110
TA040	ER 16 Shim			₺98
TA061	16 ER Shim			₺118
TA060	16 IR Shim			₺118
TA062	22 ER Shim			₺131
TA063	22 IR Shim			₺131
TA064	27 ER Shim			₺269
TA065	27 IR Shim			₺269

S 3 2 T D D U N R 1 5

1	2	3	4	5	6	7	8	9
Type of Shank Schaftansführung	Shank Schaft	Tool Length Werkzeuglänge	Clamping System Klemmsystem	Uç Form WSP-Form	Tool Type Shank Werkzeugtyp	Insert Clearance WSP-Freiwinkel	Holder Execution Bearbestungsrichtung	Cutting Edge WSP-Größe
A: Çelik Gövdeli içten Sogutmalı Coolan Through Steel Shank Mit Kühlbohrung			D M P S 	A B C D E H K L M O P R S T V W	F G I J U V Z X	3° 5° 7° 15° 20° 25° 30° 11° Özel Special O	R	A B C D E K L M O P R S T V W
	06 = 6	D = 60						
	08 = 8	E = 70						
	10 = 10	F = 80						
	12 = 12	G = 90						
	14 = 14	H = 100						
	16 = 16	J = 110						
	20 = 20	K = 125						
	22 = 22	L = 140						
	25 = 25	M = 150						
32 = 32	N = 160							
40 = 40	P = 170							
50 = 50	Q = 180							
C: Toz Metal Gövdeli Hardmetal Shank Hartmetall Stahlkopf		R = 200					 	
		S = 250						
		T = 300						
		U = 350						
		V = 400						
E: Toz Metal Gövdeli içten Sogutmalı Hardmetal Shank Sogutmalı Hole Hartmetall Schaft mit Stahlkopf und Kühlbohrung		W = 450						
		Y = 500						
		X = ÖZEL Special Sonderform						
S: Çelik Gövdeli Steel Shank Stahl Schaft								

	D	D	J	N	R	20	20	K	15
	1	2	3	4	5	6	7	8	9
Clamping Sistem KlemmSistem	Cutting Style Plattenform	Type Werkzeugtyp	Clearance angle WSP-Freiwinkel	Holder Execution Bearbeitungsrichtung	Height of Shank Schaftquerschnitts	Width of Shank Schaftbreite	Leng of Holder Werkzeuglänge	Leng of Holder Werkzeuglänge	
<p>D</p>  <p>M</p>  <p>P</p>  <p>S</p> 	<p>A </p> <p>B </p> <p>C </p> <p>D </p> <p>E </p> <p>H </p> <p>K </p> <p>L </p> <p>M </p> <p>O </p> <p>P </p> <p>R </p> <p>S </p> <p>T </p> <p>V </p> <p>W </p>	<p>A </p> <p>B </p> <p>C </p> <p>D </p> <p>E </p> <p>F </p> <p>G </p> <p>J </p> <p>K </p> <p>L </p> <p>N </p> <p>P </p> <p>Q </p> <p>R </p> <p>S </p> <p>V </p>	<p>A </p> <p>B </p> <p>C </p> <p>D </p> <p>E </p> <p>F </p> <p>G </p> <p>P </p> <p>N </p> <p>Özel Special O</p>	<p>L</p>  <p>R</p>  <p>N</p> 	<p>(mm)</p> <p>06 = 6</p> <p>08 = 8</p> <p>10 = 10</p> <p>12 = 12</p> <p>14 = 14</p> <p>16 = 16</p> <p>20 = 20</p> <p>22 = 22</p> <p>25 = 25</p> <p>32 = 32</p> <p>40 = 40</p> <p>50 = 50</p>	<p>(mm)</p> <p>06 = 6</p> <p>08 = 8</p> <p>10 = 10</p> <p>12 = 12</p> <p>14 = 14</p> <p>16 = 16</p> <p>20 = 20</p> <p>22 = 22</p> <p>25 = 25</p> <p>32 = 32</p> <p>40 = 40</p> <p>50 = 50</p>	<p>(mm)</p> <p>D = 60</p> <p>E = 70</p> <p>F = 80</p> <p>G = 90</p> <p>H = 100</p> <p>J = 110</p> <p>K = 125</p> <p>L = 140</p> <p>M = 150</p> <p>N = 160</p> <p>P = 170</p> <p>Q = 180</p> <p>R = 200</p> <p>S = 250</p> <p>T = 300</p> <p>U = 350</p> <p>V = 400</p> <p>W = 450</p> <p>Y = 500</p> <p>X = ÖZEL Special Sonderform</p>	<p>A (mm) </p> <p>B </p> <p>C </p> <p>D </p> <p>E </p> <p>K </p> <p>L </p> <p>M </p> <p>O </p> <p>P </p> <p>R </p> <p>S </p> <p>T </p> <p>V </p> <p>W </p>	